



Bridgelux® E Series E13 CA LED Array

Product Data Sheet DS339

Introduction

E Series



The Bridgelux E Series E13 LED array products deliver high quality light in a compact and high cost-effective solid-state lighting package. These chip-on-board (COB) arrays can be efficiently driven at twice the nominal drive current, enabling design flexibility not previously possible. The E Series E13 CA is designed to support a wide range of luminaires and replacement lamps for both indoor and outdoor general lighting applications with highly competitive cost and good performance.

E Series E13 CA is available in a variety of electrical, CCT and CRI combinations providing substantial design flexibility and energy efficiencies.

Typical applications include, replacement lamps, and task, accent, spot, track, wide area, security, wall pack and down lights.

Features

- Compact, high flux density light source
- Uniform, high quality illumination
- Streamlined thermal path
- ENERGY STAR® / ANSI compliant color binning structure with 2, 3 and 4 SDCM options
- Higher energy efficiency than incandescent, halogen and CFL lamps
- Industry standard DC voltage operation
- Instant light with unlimited dimming
- RoHS and REACH compliant

Benefits

- Easy for second optics design
- Clean white light without pixilation
- Significantly reduced thermal resistance
- Easy for LED driver selection
- Easy to use with daylight and motion detectors to enable increased energy savings
- Reduced maintenance costs
- Environmentally friendly



Contents

Product Feature Map	2
Product Nomenclature	2
Product Selection Guide	4
Performance at Commonly Used Drive Currents	7
Electrical Characteristics	13
Absolute Maximum Ratings	14
Performance Curves	15
Typical Radiation Pattern	18
Typical Color Spectrum	19
Operating Limits	21
Color Binning Information	22
Mechanical Dimensions	23
Packaging and Labeling	25
Design Resources	26
About Bridgelux	27

Product Feature Map

Bridgelux arrays are fully engineered devices that provide consistent thermal and optical performance on an engineered mechanical platform.

The arrays incorporate several features to simplify design integration and assembly.

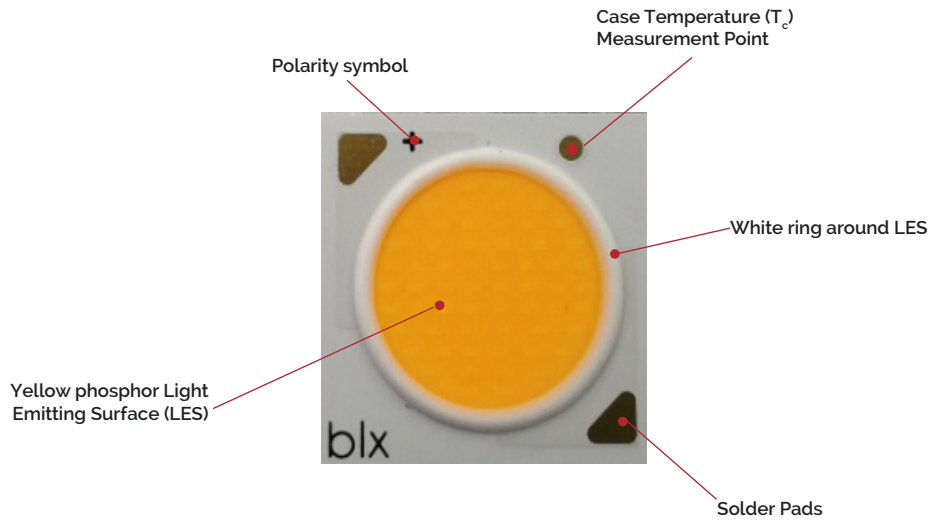

Note: Part number and lot codes are scribed on back of array

Product Nomenclature

The part number designation for Bridgelux E Series LED arrays is explained as follows:

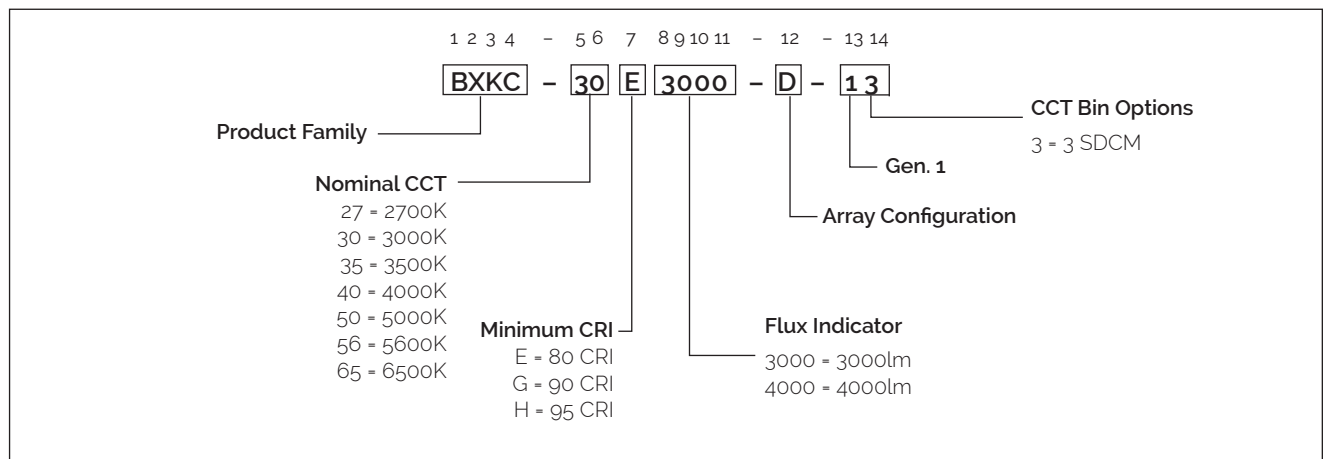

Product Selection Guide

Table 1: Selection Guide, Measurement Data (Tc=25°C)

Part Number	Nominal CCT ¹ (K)	Typical CRI	Nominal Drive Current (mA)	Typical Pulsed Flux ^{2,3,4} Tc = 25°C (lm)	Minimum Pulsed Flux ^{2,4,5} Tc = 25°C (lm)	Typical Vf (V)	Typical Power (W)	Typical Efficacy (lm/W)
BXKC-27E3000-D-13	2700	82.0	450	2252	1959	36.0	16.2	139
BXKC-27G3000-D-13	2700	92.0	450	1867	1624	36.0	16.2	115
BXKC-27H3000-D-13	2700	96.0	450	1755	1527	36.0	16.2	108
BXKC-30E3000-D-13	3000	82.0	450	2370	2062	36.0	16.2	146
BXKC-30G3000-D-13	3000	92.0	450	1965	1710	36.0	16.2	121
BXKC-30H3000-D-13	3000	96.0	450	1783	1551	36.0	16.2	110
BXKC-35E3000-D-13	3500	82.0	450	2429	2113	36.0	16.2	150
BXKC-35G3000-D-13	3500	92.0	450	2014	1752	36.0	16.2	124
BXKC-35H3000-D-13	3500	96.0	450	1880	1636	36.0	16.2	116
BXKC-40E3000-D-13	4000	82.0	450	2480	2158	36.0	16.2	153
BXKC-40G3000-D-13	4000	92.0	450	2070	1801	36.0	16.2	128
BXKC-40H3000-D-13	4000	96.0	450	1944	1691	36.0	16.2	120
BXKC-50E3000-D-14	5000	81.5	450	2548	2217	36.0	16.2	157
BXKC-50G3000-D-14	5000	91.0	450	2112	1838	36.0	16.2	130
BXKC-56E3000-D-14	5600	81.5	450	2545	2214	36.0	16.2	157
BXKC-65E3000-D-14	6500	81.5	450	2545	2214	36.0	16.2	157
BXKC-27E4000-E-13	2700	82.0	550	2694	2343	36.0	19.8	136
BXKC-27G4000-E-13	2700	92.0	550	2290	1992	36.0	19.8	116
BXKC-27H4000-E-13	2700	96.0	550	2148	1869	36.0	19.8	108
BXKC-30E4000-E-13	3000	82.0	550	2835	2467	36.0	19.8	143
BXKC-30G4000-E-13	3000	92.0	550	2410	2097	36.0	19.8	122
BXKC-30H4000-E-13	3000	96.0	550	2182	1898	36.0	19.8	110
BXKC-35E4000-E-13	3500	82.0	550	2935	2553	36.0	19.8	148
BXKC-35G4000-E-13	3500	92.0	550	2494	2170	36.0	19.8	126
BXKC-35H4000-E-13	3500	96.0	550	2300	2001	36.0	19.8	116
BXKC-40E4000-E-13	4000	82.0	550	3028	2634	36.0	19.8	153
BXKC-40G4000-E-13	4000	92.0	550	2574	2239	36.0	19.8	130
BXKC-40H4000-E-13	4000	96.0	550	2379	2070	36.0	19.8	120
BXKC-50E4000-E-14	5000	81.5	550	3048	2652	36.0	19.8	154
BXKC-50G4000-E-14	5000	91.0	550	2591	2254	36.0	19.8	131
BXKC-56E4000-E-14	5600	81.5	550	3048	2652	36.0	19.8	154
BXKC-65E4000-E-14	6500	81.5	550	3048	2652	36.0	19.8	154

Notes for Table 1:

- Nominal CCT as defined by ANSI C78.377-2011.
- Products tested under pulsed condition (10ms pulse width) at nominal test current where Tj (junction temperature) - Tc (case temperature) = 25°C.
- Typical performance values are provided as a reference only and are not a guarantee of performance.
- Bridgelux maintains a ±7% tolerance on flux measurements.
- Minimum flux values at the nominal test current are guaranteed by 100% test.

Product Selection Guide

Table 2: Selection Guide, Measurement Data (Tc=85°C)

Part Number	Nominal CCT ¹ (K)	Minimum CRI	Typical CRI	Nominal Drive Current (mA)	Typical DC Flux ^{2,3} Tc = 85°C (lm)	Minimum DC Flux ⁴ Tc = 85°C (lm)	Typical Vf (V)	Typical Power (W)	Typical Efficacy (lm/W)
BXKC-27E3000-D-13	2700	80	82	450	2026	1763	35.1	15.8	128
BXKC-27G3000-D-13	2700	90	92	450	1680	1462	35.1	15.8	106
BXKC-27H3000-D-13	2700	95	96	450	1580	1374	35.1	15.8	100
BXKC-30E3000-D-13	3000	80	82	450	2133	1856	35.1	15.8	135
BXKC-30G3000-D-13	3000	90	92	450	1769	1539	35.1	15.8	112
BXKC-30H3000-D-13	3000	95	96	450	1605	1396	35.1	15.8	102
BXKC-35E3000-D-13	3500	80	82	450	2208	1921	35.1	15.8	140
BXKC-35G3000-D-13	3500	90	92	450	1830	1592	35.1	15.8	116
BXKC-35H3000-D-13	3500	95	96	450	1692	1472	35.1	15.8	107
BXKC-40E3000-D-13	4000	80	82	450	2232	1942	35.1	15.8	141
BXKC-40G3000-D-13	4000	90	92	450	1863	1621	35.1	15.8	118
BXKC-40H3000-D-13	4000	95	96	450	1750	1522	35.1	15.8	111
BXKC-50E3000-D-14	5000	80	81.5	450	2293	1995	35.1	15.8	145
BXKC-50G3000-D-14	5000	90	91	450	1901	1654	35.1	15.8	120
BXKC-56E3000-D-14	5600	80	81.5	450	2291	1993	35.1	15.8	145
BXKC-65E3000-D-14	6500	80	81.5	450	2291	1993	35.1	15.8	145
BXKC-27E4000-E-13	2700	80	82	550	2424	2109	35.4	19.4	125
BXKC-27G4000-E-13	2700	90	92	550	2061	1793	35.4	19.4	106
BXKC-27H4000-E-13	2700	95	96	550	1933	1682	35.4	19.4	100
BXKC-30E4000-E-13	3000	80	82	550	2552	2220	35.4	19.4	131
BXKC-30G4000-E-13	3000	90	92	550	2169	1887	35.4	19.4	112
BXKC-30H4000-E-13	3000	95	96	550	1964	1709	35.4	19.4	101
BXKC-35E4000-E-13	3500	80	82	550	2641	2298	35.4	19.4	136
BXKC-35G4000-E-13	3500	90	92	550	2245	1953	35.4	19.4	115
BXKC-35H4000-E-13	3500	95	96	550	2070	1801	35.4	19.4	107
BXKC-40E4000-E-13	4000	80	82	550	2725	2371	35.4	19.4	140
BXKC-40G4000-E-13	4000	90	92	550	2316	2015	35.4	19.4	119
BXKC-40H4000-E-13	4000	95	96	550	2141	1863	35.4	19.4	110
BXKC-50E4000-E-14	5000	80	81.5	550	2743	2387	35.4	19.4	141
BXKC-50G4000-E-14	5000	90	91	550	2332	2029	35.4	19.4	120
BXKC-56E4000-E-14	5600	80	81.5	550	2743	2387	35.4	19.4	141
BXKC-65E4000-E-14	6500	80	81.5	550	2743	2387	35.4	19.4	141

Notes for Table 2:

1. Nominal CCT as defined by ANSI C78.377-2011.
2. Typical stabilized DC performance values are provided as reference only and are not a guarantee of performance.
3. Typical performance is estimated based on operation under DC (direct current) with LED array mounted onto a heat sink with thermal interface material and the case temperature maintained at 85°C. Based on Bridgelux test setup, values may vary depending on the thermal design of the luminaire and/or the exposed environment to which the product is subjected.
4. Minimum flux values at elevated temperatures are provided for reference only and are not guaranteed by 100% production testing. Based on Bridgelux test setup, values may vary depending on the thermal design of the luminaire and/or the exposed environment to which the product is subjected.

European Product Registry for Energy Labeling

The European Product Registry for Energy Labeling (EPREL) is defined in the EU Regulation 2017/1369 to provide important energy efficiency information to consumers. Together with Energy Labeling Regulation ELR (EU) 2019/2015 which was amended by regulation (EU) 2021/340 for energy labelling of light sources, manufacturers are required to declare an energy class based on key technical specifications from each of their product and register it in an open data base managed by EPREL. It is now a legal requirement for a vendor of light sources to upload information about their products into the EPREL database before placing these products on the market in the EU.

Table 3 below provides a list of part numbers that are in compliance with ELR and are currently listed in the EPREL database.

At Bridgelux, we are fully committed to supplying products that are compliant with pertinent laws, rules, and obligation imposed by relevant government bodies including the European Energy Labeling regulation. Customers can use these products with full confidence for any projects that fall under the ELR.

Table 3: Part numbers registered in European Product Registry for Energy Labeling

PART NUMBER ¹	CCT (K)	CRI	Current ² (mA)	Vf (V)	Useful flux ³ (Φ_{use}) at 85C (lm)	Power (W)	Efficacy (lm/W)	Energy efficiency class ⁴	Registration No	URL to Product Information Sheet in EPREL Database
BXKC-27E3000-D-13	2700	80	700	37.4	2976	26.2	114	F	1116598	https://eprelec.europa.eu/qr/1116598
BXKC-27E4000-E-13	2700	80	780	36.9	3283	28.8	114	F	1116603	https://eprelec.europa.eu/qr/1116603
BXKC-27G3000-D-13	2700	90	410	34.9	1546	14.3	108	F	1116655	https://eprelec.europa.eu/qr/1116655
BXKC-27G4000-E-13	2700	90	480	34.8	1825	16.7	109	F	1116660	https://eprelec.europa.eu/qr/1116660
BXKC-30E3000-D-13	3000	80	810	38.3	3539	31.0	114	F	1116726	https://eprelec.europa.eu/qr/1116726
BXKC-30E4000-E-13	3000	80	910	37.7	3937	34.3	115	F	1116731	https://eprelec.europa.eu/qr/1116731
BXKC-30G3000-D-13	3000	90	480	35.5	1873	17.1	110	F	1116783	https://eprelec.europa.eu/qr/1116783
BXKC-30G4000-E-13	3000	90	560	35.3	2203	19.8	111	F	1116788	https://eprelec.europa.eu/qr/1116788
BXKC-35E3000-D-13	3500	80	860	38.6	3811	33.2	115	F	1116854	https://eprelec.europa.eu/qr/1116854
BXKC-35E4000-E-13	3500	80	1000	38.2	4412	38.2	115	F	1116859	https://eprelec.europa.eu/qr/1116859
BXKC-35G3000-D-13	3500	90	510	35.8	2025	18.3	111	F	1116911	https://eprelec.europa.eu/qr/1116911
BXKC-35G4000-E-13	3500	90	620	35.8	2493	22.2	112	F	1116916	https://eprelec.europa.eu/qr/1116916
BXKC-40E3000-D-13	4000	80	910	38.9	4074	35.4	115	F	1116982	https://eprelec.europa.eu/qr/1116982
BXKC-40E4000-E-13	4000	80	1090	38.8	4891	42.2	116	F	1116987	https://eprelec.europa.eu/qr/1116987
BXKC-40G3000-D-13	4000	90	560	36.3	2259	20.3	111	F	1117039	https://eprelec.europa.eu/qr/1117039
BXKC-40G4000-E-13	4000	90	690	36.3	2823	25.0	113	F	1117044	https://eprelec.europa.eu/qr/1117044
BXKC-50E3000-D-14	5000	80	960	39.2	4371	37.6	116	F	1117081	https://eprelec.europa.eu/qr/1117081
BXKC-50E4000-E-14	5000	80	1110	38.9	4998	43.1	116	F	1117083	https://eprelec.europa.eu/qr/1117083

Notes for Table 3:

- All device listed here must be disposed as e-waste upon its end of life according to local country guideline in each country.
- For information on performance values at alternative drive conditions, please refer to the Product Selection Guide, Absolute Maximum Rating Table and Performance Curves in this data sheet.
- For a definition of useful luminous flux (Φ_{use}), please see the ELR regulations at <https://tinyurl.com/4b6zvt4m>.
- EPREL requires an arrow symbol containing the letter of the energy efficiency class to be displayed, on technical promotional material. Refer to this energy efficiency class column for specific energy efficiency class on each part number.

European Product Registry for Energy Labeling

Table 3: Part numbers registered in European Product Registry for Energy Labeling (Continued)

PART NUMBER ¹	CCT (K)	CRI	Current ² (mA)	Vf (V)	Useful flux ³ (Φ_{use}) at 85°C (lm)	Power (W)	Efficacy (lm/W)	Energy efficiency class ⁴ 	Registration No	URL to Product Information Sheet in EPREL Database
BXKC-50G3000-D-14	5000	90	590	36.5	2412	21.6	112	F	1117101	https://eprelec.europa.eu/qr/1117101
BXKC-50G4000-E-14	5000	90	700	36.3	2878	25.4	113	F	1117102	https://eprelec.europa.eu/qr/1117102
BXKC-56E3000-D-14	5600	80	960	39.2	4366	37.6	116	F	1118890	https://eprelec.europa.eu/qr/1118890
BXKC-56E4000-E-14	5600	80	1110	38.9	4998	43.1	116	F	1118892	https://eprelec.europa.eu/qr/1118892
BXKC-65E3000-D-14	6500	80	960	39.2	4366	37.6	116	F	1117124	https://eprelec.europa.eu/qr/1117124
BXKC-65E4000-E-14	6500	80	1110	38.9	4998	43.1	116	F	1117126	https://eprelec.europa.eu/qr/1117126

Notes for Table 3:

1. All device listed here must be disposed as e-waste upon its end of life according to local country guideline in each country.
2. For information on performance values at alternative drive conditions, please refer to the Product Selection Guide, Absolute Maximum Rating Table and Performance Curves in this data sheet.
3. For a definition of useful luminous flux (Φ_{use}), please see the ELR regulations at <https://tinyurl.com/4b6zv4m>.
4. EPREL requires an arrow symbol containing the letter of the energy efficiency class to be displayed, on technical promotional material. Refer to this energy efficiency class column for specific energy efficiency class on each part number.

Performance at Commonly Used Drive Currents

E Series LED arrays are tested to the specifications shown using the nominal drive currents in Table 1. E Series may also be driven at other drive currents dependent on specific application design requirements. The performance at any drive current can be derived from the current vs. voltage characteristics shown in Figures 1 and 2 and the flux vs. current characteristics shown in Figures 3 and 4. The performance at commonly used drive currents is summarized in Table 4.

Table 4: Product Performance at Commonly Used Drive Currents (Continued)

Part Number	Minimum CRI	Drive Current ¹ (mA)	Typical Vf Tc = 25°C (V)	Typical Power ² Tc = 25°C (W)	Typical Pulsed Flux ² Tc = 25°C (lm)	Typical DC Flux ² Tc = 85°C (lm)	Typical Efficacy ² Tc = 25°C (lm/W)
BXKC-27E3000-D-13	80	120	32.6	3.9	662	625	169
		240	33.9	8.1	1268	1178	156
		450	36	16.2	2252	2026	139
		480	36.3	17.4	2385	2135	137
		720	38.4	27.7	3385	2894	122
		960	40	38.4	4293	3435	112
BXKC-27G3000-D-13	90	120	32.6	3.9	549	518	140
		240	33.9	8.1	1051	976	129
		450	36	16.2	1867	1680	115
		480	36.3	17.4	1978	1770	114
		720	38.4	27.7	2807	2399	101
		960	40	38.4	3559	2848	93
BXKC-27H3000-D-13	95	120	32.6	3.9	516	465	132
		240	33.9	8.1	989	890	122
		450	36	16.2	1755	1580	108
		480	36.3	17.4	1859	1673	107
		720	38.4	27.7	2638	2375	95
		960	40	38.4	3346	3012	87
BXKC-30E3000-D-13	80	120	32.6	3.9	697	658	178
		240	33.9	8.1	1334	1240	164
		450	36	16.2	2370	2133	146
		480	36.3	17.4	2511	2248	144
		720	38.4	27.7	3563	3046	129
		960	40	38.4	4519	3616	118
BXKC-30G3000-D-13	90	120	32.6	3.9	578	545	148
		240	33.9	8.1	1106	1028	136
		450	36	16.2	1965	1769	121
		480	36.3	17.4	2082	1863	120
		720	38.4	27.7	2954	2525	107
		960	40	38.4	3746	2998	97

Notes for Table 4:

1. Alternate drive currents are provided for reference only and are not a guarantee of performance.
2. Typical stabilized DC performance values are provided as reference only and are not a guarantee of performance.

Performance at Commonly Used Drive Currents

Table 4: Product Performance at Commonly Used Drive Currents (Continued)

Part Number	Minimum CRI	Drive Current ¹ (mA)	Typical Vf Tc = 25°C (V)	Typical Power ² Tc = 25°C (W)	Typical Pulsed Flux ² Tc = 25°C (lm)	Typical DC Flux ² Tc = 85°C (lm)	Typical Efficacy ² Tc = 25°C (lm/W)
BXKC-30H3000-D-13	95	120	32.6	3.9	525	472	135
		240	33.9	8.1	1004	904	124
		450	36	16.2	1783	1605	110
		480	36.3	17.4	1889	1700	109
		720	38.4	27.7	2681	2412	97
		960	40	38.4	3400	3060	89
BXKC-35E3000-D-13	80	120	32.6	3.9	714	674	183
		240	33.9	8.1	1368	1271	168
		450	36	16.2	2429	2186	150
		480	36.3	17.4	2574	2304	148
		720	38.4	27.7	3652	3122	132
		960	40	38.4	4632	3706	121
BXKC-35G3000-D-13	90	120	32.6	3.9	592	559	152
		240	33.9	8.1	1134	1054	139
		450	36	16.2	2014	1813	124
		480	36.3	17.4	2134	1910	123
		720	38.4	27.7	3028	2589	109
		960	40	38.4	3840	3073	100
BXKC-35H3000-D-13	95	120	32.6	3.9	553	498	142
		240	33.9	8.1	1059	953	131
		450	36	16.2	1880	1692	116
		480	36.3	17.4	1992	1793	114
		720	38.4	27.7	2826	2544	102
		960	40	38.4	3585	3226	93
BXKC-40E3000-D-13	80	120	32.6	3.9	729	688	187
		240	33.9	8.1	1396	1297	171
		450	36	16.2	2480	2232	153
		480	36.3	17.4	2627	2352	151
		720	38.4	27.7	3729	3187	135
		960	40	38.4	4728	3783	123
BXKC-40G3000-D-13	90	120	32.6	3.9	609	575	156
		240	33.9	8.1	1166	1083	143
		450	36	16.2	2070	1863	128
		480	36.3	17.4	2193	1963	126
		720	38.4	27.7	3112	2660	113
		960	40	38.4	3947	3158	103

Notes for Table 4:

1. Alternate drive currents are provided for reference only and are not a guarantee of performance.
2. Typical stabilized DC performance values are provided as reference only and are not a guarantee of performance.

Performance at Commonly Used Drive Currents

Table 4: Product Performance at Commonly Used Drive Currents (Continued)

Part Number	Minimum CRI	Drive Current ¹ (mA)	Typical Vf Tc = 25°C (V)	Typical Power ² Tc = 25°C (W)	Typical Pulsed Flux ² Tc = 25°C (lm)	Typical DC Flux ² Tc = 85°C (lm)	Typical Efficacy ² Tc = 25°C (lm/W)
BXKC-40H3000-D-13	95	120	32.6	3.9	572	515	147
		240	33.9	8.1	1095	986	135
		450	36	16.2	1944	1750	120
		480	36.3	17.4	2060	1854	118
		720	38.4	27.7	2923	2630	106
		960	40	38.4	3707	3336	97
BXKC-50E3000-D-14	80	120	32.6	3.9	749	707	192
		240	33.9	8.1	1435	1333	176
		450	36	16.2	2548	2293	157
		480	36.3	17.4	2699	2416	155
		720	38.4	27.7	3831	3274	139
		960	40	38.4	4857	3887	126
BXKC-50G3000-D-14	90	120	32.6	3.9	621	586	159
		240	33.9	8.1	1189	1105	146
		450	36	16.2	2112	1901	130
		480	36.3	17.4	2238	2003	129
		720	38.4	27.7	3176	2715	115
		960	40	38.4	4027	3223	105
BXKC-56E3000-D-14	80	120	32.6	3.9	749	706	191
		240	33.9	8.1	1433	1331	176
		450	36	16.2	2545	2291	157
		480	36.3	17.4	2696	2414	155
		720	38.4	27.7	3826	3271	138
		960	40	38.4	4852	3883	126
BXKC-65E3000-D-14	80	120	32.6	3.9	749	706	191
		240	33.9	8.1	1433	1331	176
		450	36	16.2	2545	2291	157
		480	36.3	17.4	2696	2414	155
		720	38.4	27.7	3826	3271	138
		960	40	38.4	4852	3883	126
BXKC-27E4000-E-13	80	150	33	4.9	805	740	163
		300	34.2	10.3	1546	1419	150
		550	36	19.8	2694	2424	136
		600	36.4	21.8	2908	2609	133
		900	38.5	34.6	4115	3611	119
		1200	40.2	48.2	5233	4421	109

Notes for Table 4:

1. Alternate drive currents are provided for reference only and are not a guarantee of performance.
2. Typical stabilized DC performance values are provided as reference only and are not a guarantee of performance.

Performance at Commonly Used Drive Currents

Table 4: Product Performance at Commonly Used Drive Currents (Continued)

Part Number	Minimum CRI	Drive Current ¹ (mA)	Typical Vf Tc = 25°C (V)	Typical Power ² Tc = 25°C (W)	Typical Pulsed Flux ² Tc = 25°C (lm)	Typical DC Flux ² Tc = 85°C (lm)	Typical Efficacy ² Tc = 25°C (lm/W)
BXKC-27G4000-E-13	90	150	33	49	684	629	138
		300	34.2	10.3	1314	1206	128
		550	36	19.8	2290	2061	116
		600	36.4	21.8	2471	2218	113
		900	38.5	34.6	3498	3069	101
		1200	40.2	48.2	4448	3758	92
BXKC-27H4000-E-13	95	150	33	49	642	578	131
		300	34.2	10.3	1233	1109	120
		550	36	19.8	2148	1933	108
		600	36.4	21.8	2318	2086	106
		900	38.5	34.6	3282	2954	95
		1200	40.2	48.2	4173	3756	87
BXKC-30E4000-E-13	80	150	33	49	848	779	171
		300	34.2	10.3	1627	1493	158
		550	36	19.8	2835	2552	143
		600	36.4	21.8	3061	2747	140
		900	38.5	34.6	4332	3801	125
		1200	40.2	48.2	5508	4654	114
BXKC-30G4000-E-13	90	150	33	49	720	662	146
		300	34.2	10.3	1383	1269	135
		550	36	19.8	2410	2169	122
		600	36.4	21.8	2601	2335	119
		900	38.5	34.6	3682	3231	106
		1200	40.2	48.2	4682	3956	97
BXKC-30H4000-E-13	95	150	33	49	652	587	133
		300	34.2	10.3	1252	1127	122
		550	36	19.8	2182	1964	110
		600	36.4	21.8	2355	2119	108
		900	38.5	34.6	3334	3000	96
		1200	40.2	48.2	4239	3815	88
BXKC-35E4000-E-13	80	150	33	49	877	807	177
		300	34.2	10.3	1684	1545	164
		550	36	19.8	2935	2641	148
		600	36.4	21.8	3168	2843	145
		900	38.5	34.6	4484	3934	129
		1200	40.2	48.2	5701	4816	118

Notes for Table 4:

1. Alternate drive currents are provided for reference only and are not a guarantee of performance.
2. Typical stabilized DC performance values are provided as reference only and are not a guarantee of performance.

Performance at Commonly Used Drive Currents

Table 4: Product Performance at Commonly Used Drive Currents (Continued)

Part Number	Minimum CRI	Drive Current ¹ (mA)	Typical Vf Tc = 25°C (V)	Typical Power ² Tc = 25°C (W)	Typical Pulsed Flux ² Tc = 25°C (lm)	Typical DC Flux ² Tc = 85°C (lm)	Typical Efficacy ² Tc = 25°C (lm/W)
BXKC-35G4000-E-13	90	150	33	49	746	686	151
		300	34.2	10.3	1431	1314	139
		550	36	19.8	2494	2245	126
		600	36.4	21.8	2693	2416	123
		900	38.5	34.6	3811	3344	110
		1200	40.2	48.2	4846	4094	100
BXKC-35H4000-E-13	95	150	33	49	687	618	140
		300	34.2	10.3	1320	1188	128
		550	36	19.8	2300	2070	116
		600	36.4	21.8	2482	2234	114
		900	38.5	34.6	3514	3163	102
		1200	40.2	48.2	4468	4021	93
BXKC-40E4000-E-13	80	150	33	49	905	832	183
		300	34.2	10.3	1738	1595	169
		550	36	19.8	3028	2725	153
		600	36.4	21.8	3269	2933	150
		900	38.5	34.6	4627	4059	134
		1200	40.2	48.2	5883	4970	122
BXKC-40G4000-E-13	90	150	33	49	769	707	156
		300	34.2	10.3	1477	1355	144
		550	36	19.8	2574	2316	130
		600	36.4	21.8	2778	2493	127
		900	38.5	34.6	3933	3450	114
		1200	40.2	48.2	5001	4225	104
BXKC-40H4000-E-13	95	150	33	49	711	640	145
		300	34.2	10.3	1365	1229	133
		550	36	19.8	2379	2141	120
		600	36.4	21.8	2568	2311	118
		900	38.5	34.6	3635	3271	105
		1200	40.2	48.2	4622	4160	96
BXKC-50E4000-E-14	80	150	33	49	911	838	184
		300	34.2	10.3	1749	1605	170
		550	36	19.8	3048	2743	154
		600	36.4	21.8	3290	2953	151
		900	38.5	34.6	4657	4086	134
		1200	40.2	48.2	5922	5003	123

Notes for Table 4:

1. Alternate drive currents are provided for reference only and are not a guarantee of performance.
2. Typical stabilized DC performance values are provided as reference only and are not a guarantee of performance.

Performance at Commonly Used Drive Currents

Table 4: Product Performance at Commonly Used Drive Currents (Continued)

Part Number	Minimum CRI	Drive Current ¹ (mA)	Typical Vf Tc = 25°C (V)	Typical Power ² Tc = 25°C (W)	Typical Pulsed Flux ² Tc = 25°C (lm)	Typical DC Flux ² Tc = 85°C (lm)	Typical Efficacy ² Tc = 25°C (lm/W)
BXKC-50G4000-E-14	90	150	33	49	774	712	157
		300	34.2	10.3	1487	1364	145
		550	36	19.8	2591	2332	131
		600	36.4	21.8	2797	2510	128
		900	38.5	34.6	3958	3473	114
		1200	40.2	48.2	5033	4252	104
BXKC-56E4000-E-14	80	150	33	49	911	838	184
		300	34.2	10.3	1749	1605	170
		550	36	19.8	3048	2743	154
		600	36.4	21.8	3290	2953	151
		900	38.5	34.6	4657	4086	134
		1200	40.2	48.2	5922	5003	123
BXKC-65E4000-E-14	80	150	33	49	911	838	184
		300	34.2	10.3	1749	1605	170
		550	36	19.8	3048	2743	154
		600	36.4	21.8	3290	2953	151
		900	38.5	34.6	4657	4086	134
		1200	40.2	48.2	5922	5003	123

Notes for Table 4:

1. Alternate drive currents are provided for reference only and are not a guarantee of performance.
2. Typical stabilized DC performance values are provided as reference only and are not a guarantee of performance.

Electrical Characteristics

Table 5: Electrical Characteristics

Part Number	Drive Current (mA)	Forward Voltage Pulsed, Tc = 25°C (V) ^{1,2,3}			Typical Coefficient of Forward Voltage ⁴ Vf/Tc (mV/°C)	Typical Thermal Resistance Junction to Case ^{5,6} Rj-c (°C/W)	Driver Selection Voltages ⁶ (V)	
		Minimum	Typical	Maximum			Vf Min. Hot ⁷ Tc = 105°C (V)	Vf Max. Cold ⁷ Tc = -40°C (V)
BXKC-xxx3000-D-1x	450	32.4	36.0	39.2	14.5	0.366	31.4	40.2
BXKC-xxx4000-E-1x	550	32.4	36.0	39.2	14.4	0.33	31.7	40.2

Notes for Table 5:

1. Parts are tested in pulsed conditions. Tc = 25°C. Pulse width is 10ms.
2. Voltage minimum and maximum are provided for reference only and are not a guarantee of performance.
3. Bridgelux maintains a tester tolerance of ± 0.10V on forward voltage measurements.
4. Typical coefficient of forward voltage tolerance is ± 0.1mV for nominal current.
5. Thermal resistance values are based from test data of a 3000K 80 CRI product.
6. Thermal resistance value was calculated using total electrical input power; optical power was not subtracted from input power. The thermal interface material used during testing is not included in the thermal resistance value.
7. Vf min hot and max cold values are provided as reference only and are not guaranteed by test. These values are provided to aid in driver design and selection over the operating range of the product.

Absolute Maximum Ratings

Table 6 : Maximum Ratings

Parameter	Maximum Rating	
LED Junction Temperature (T_j)	125°C	
Storage Temperature	-40°C to +105°C	
Operating Case Temperature ¹ (T_c)	105°C	
Soldering Temperature ³	300°C or lower for a maximum of 6 seconds	
	BXKC-xxx3000-D-1x	BXKC-xxx4000-E-1x
Maximum Drive Current ^{2,4}	960 mA	1200 mA
Maximum Reverse Voltage ⁵	-60 V	-60 V

Notes for Table 6:

1. For IEC 62717 requirement, please consult your Bridgelux sales representative.
2. Arrays may be driven at higher currents however lumen maintenance may be reduced.
3. See Bridgelux Application Notes for more information.
4. Bridgelux recommends a maximum duty cycle of 10% and pulse width of 20 ms when operating LED Arrays at maximum peak pulsed current specified. Maximum peak pulsed currents indicate values where LED Arrays can be driven without catastrophic failures.
5. Light emitting diodes are not designed to be driven in reverse voltage and will not produce light under this condition. Maximum rating provided for reference only.

Performance Curves

Figure 1: Forward Voltage vs. Forward Current

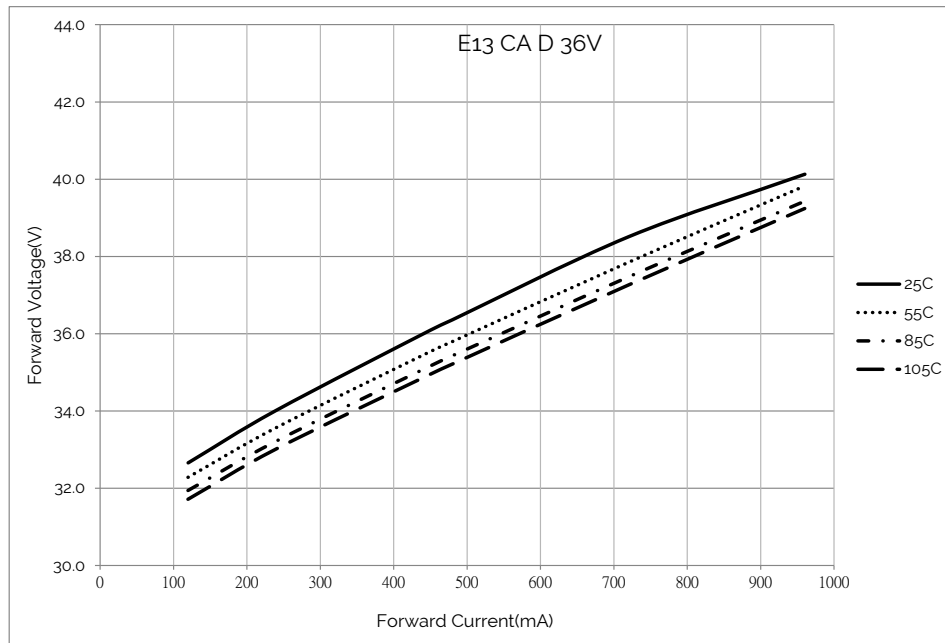
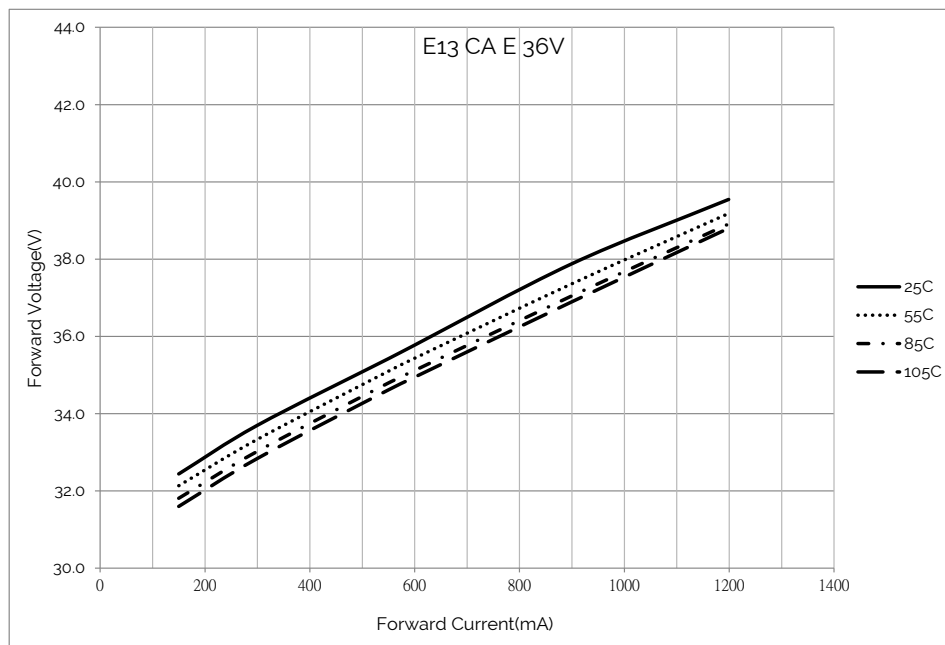

Figure 2: Forward Voltage vs. Forward Current



Notes for Figure1 and Figure 2

1. Characteristics shown based on 3000K and 80 CRI.

2. For other color SKUs, the relative luminous will vary. Please contact your Bridgelux sales representative for more information.

Performance Curves

Figure 3: Relative Luminous Flux vs. Drive Current

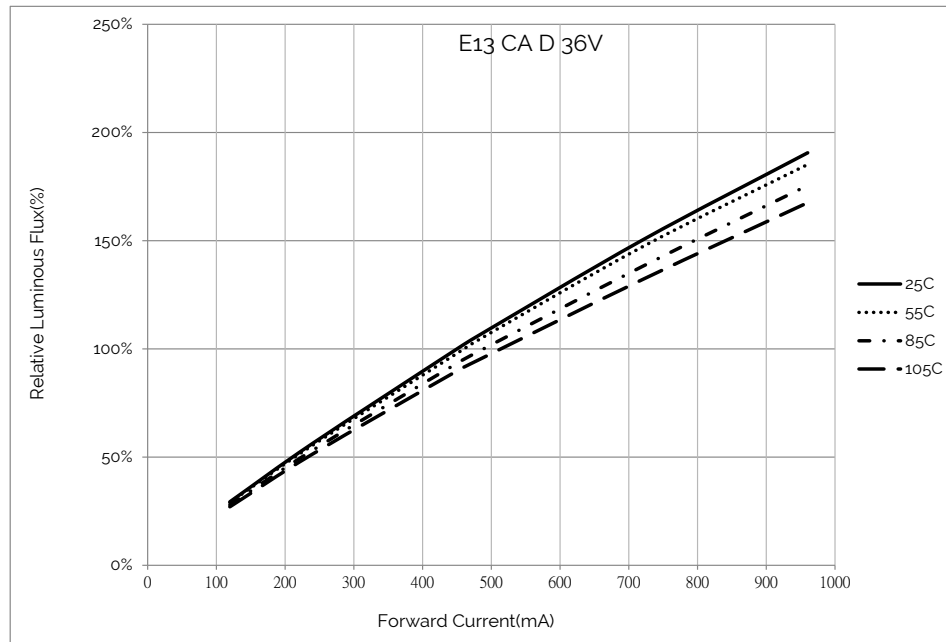
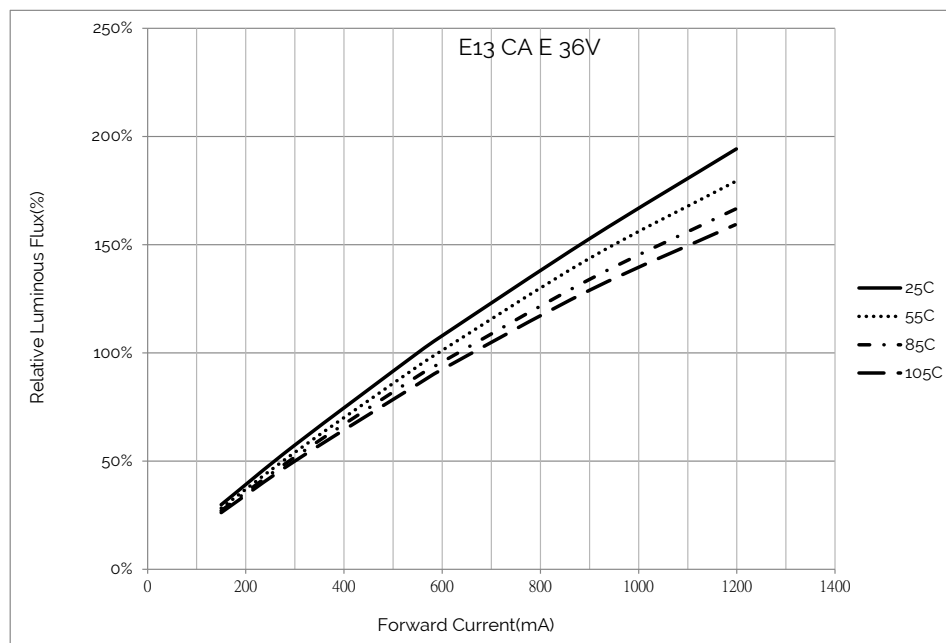

Figure 4: Relative Luminous Flux vs. Drive Current



Notes for Figure3 and Figure 4

1. Characteristics shown based on 3000K and 80 CRI.
2. For other color SKUs, the relative luminous will vary. Please contact your Bridgelux sales representative for more information.

Performance Curves

Figure 5: Relative Luminous Flux vs. Case Temperature

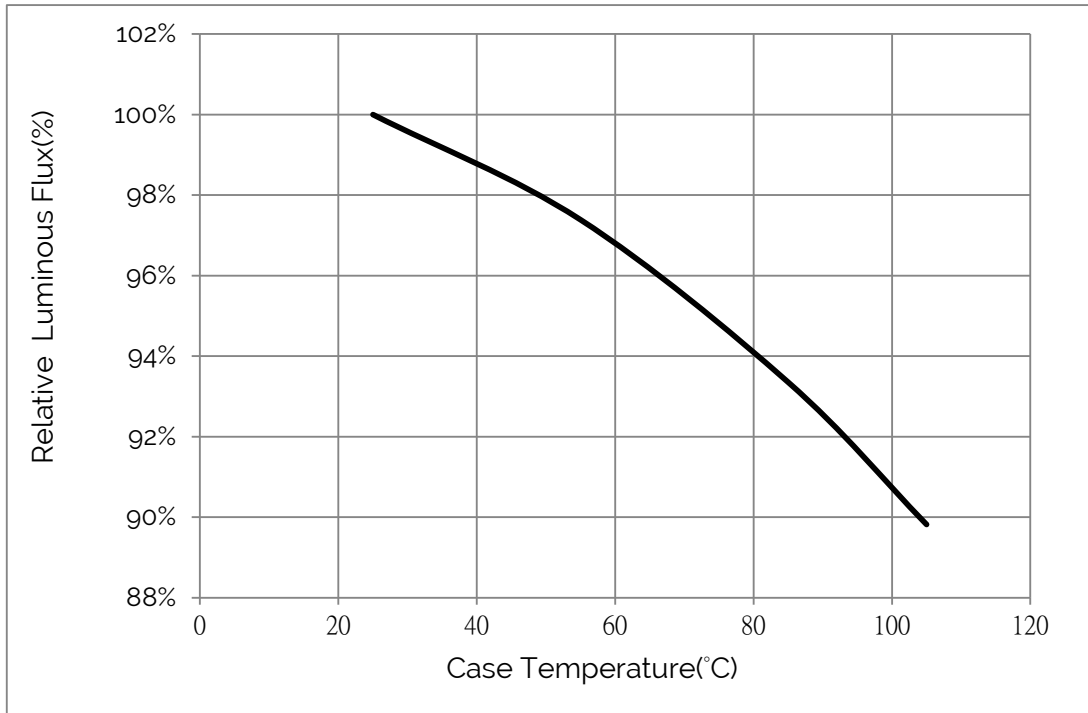

Notes for Figure 5:

1. Characteristics based on 3000K and 80 CRI.
2. For other color SKUs, the relative luminous will vary. Please contact your Bridgelux sales representative for more information.

Figure 6: Relative Voltage vs. Case Temperature

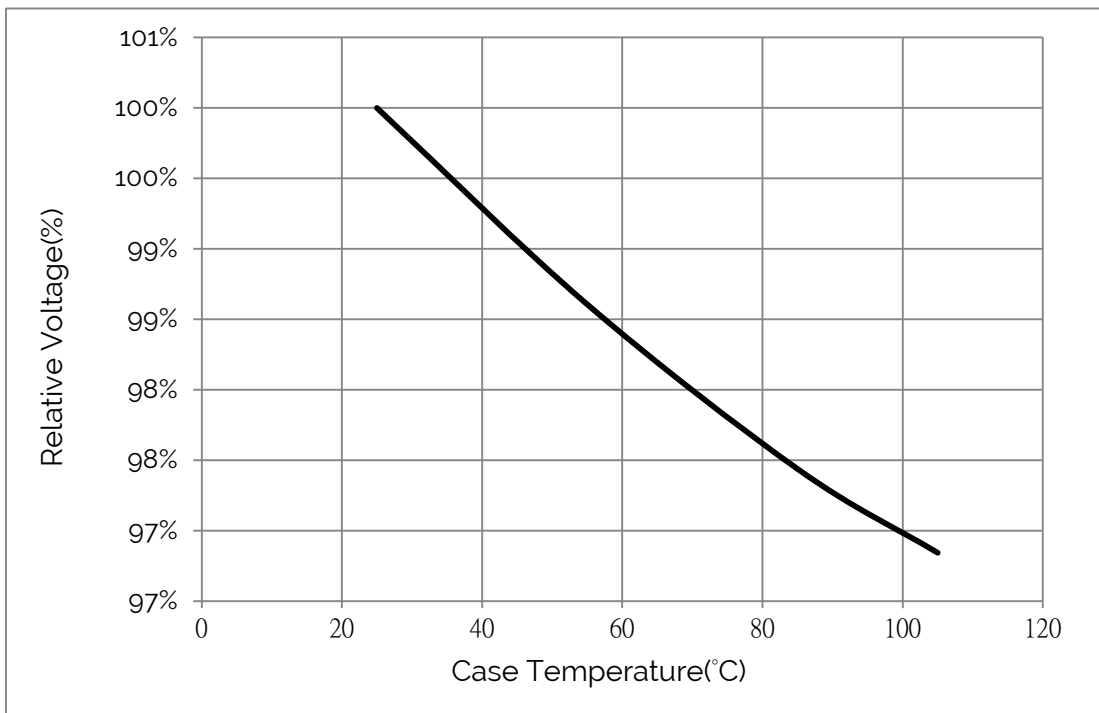

Performance Curves

Figure 7: Typical DC ccx Shift vs. Case Temperature

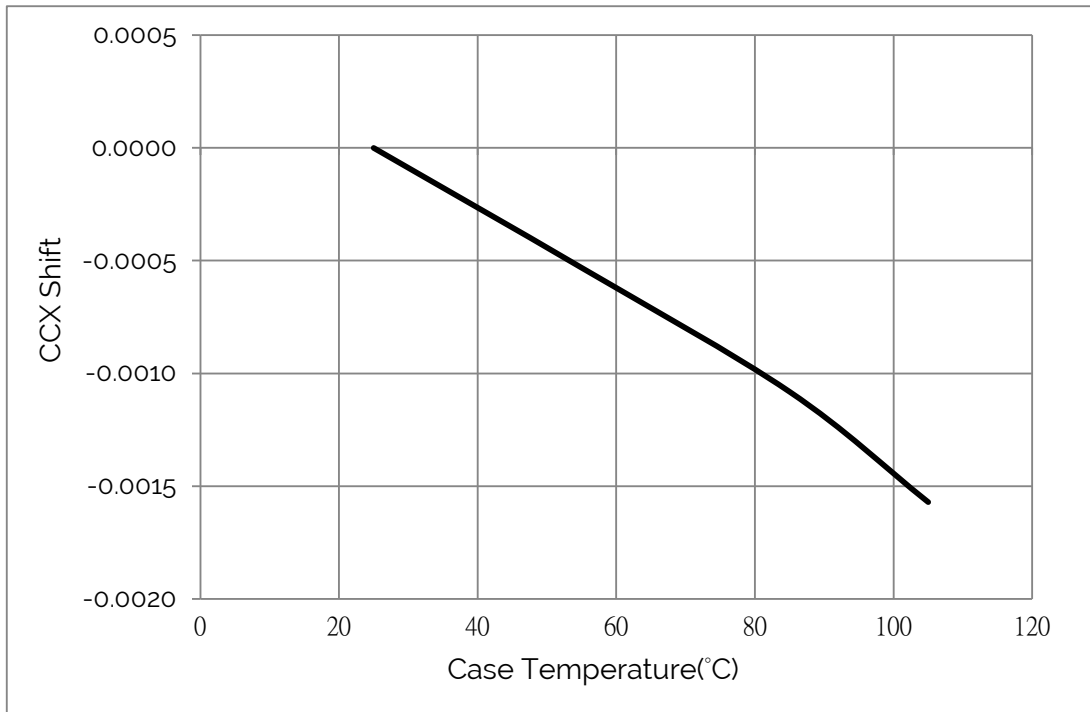
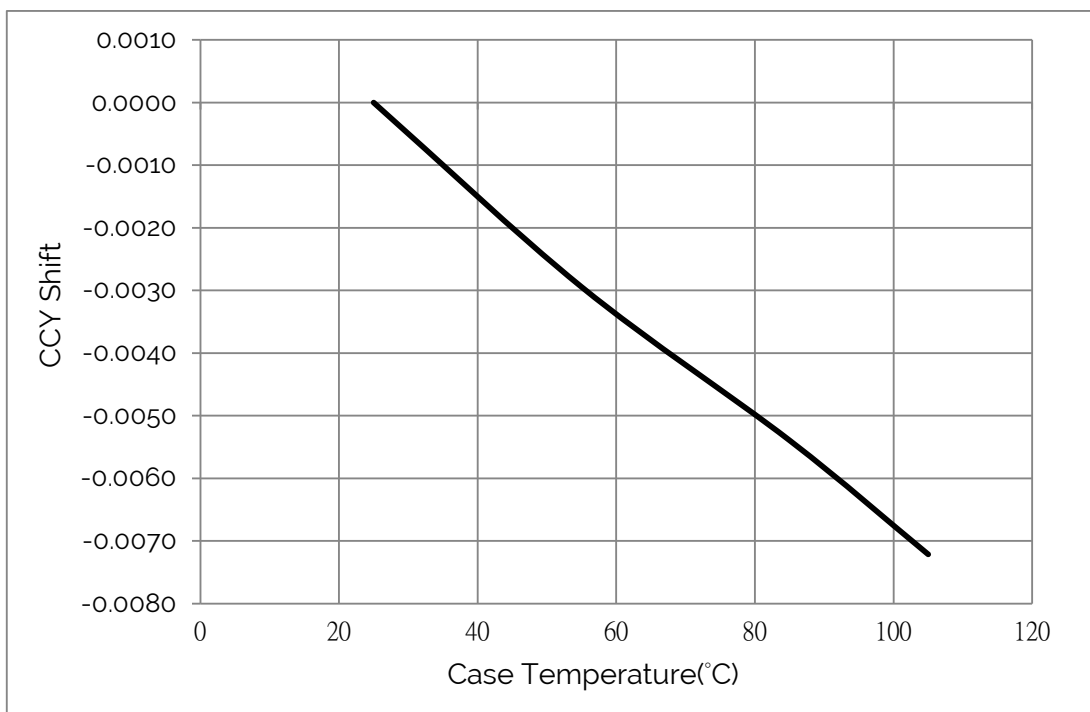

Figure 8: Typical DC ccy Shift vs. Case Temperature



Notes for Figure 7 and Figure 8:

1. Characteristics shown based on 3000K and 80 CRI.
2. For other color SKUs, the shift in color will vary. Please contact your Bridgelux sales representative for more information.

Typical Radiation Pattern

Figure 9: Typical Spatial Radiation Pattern

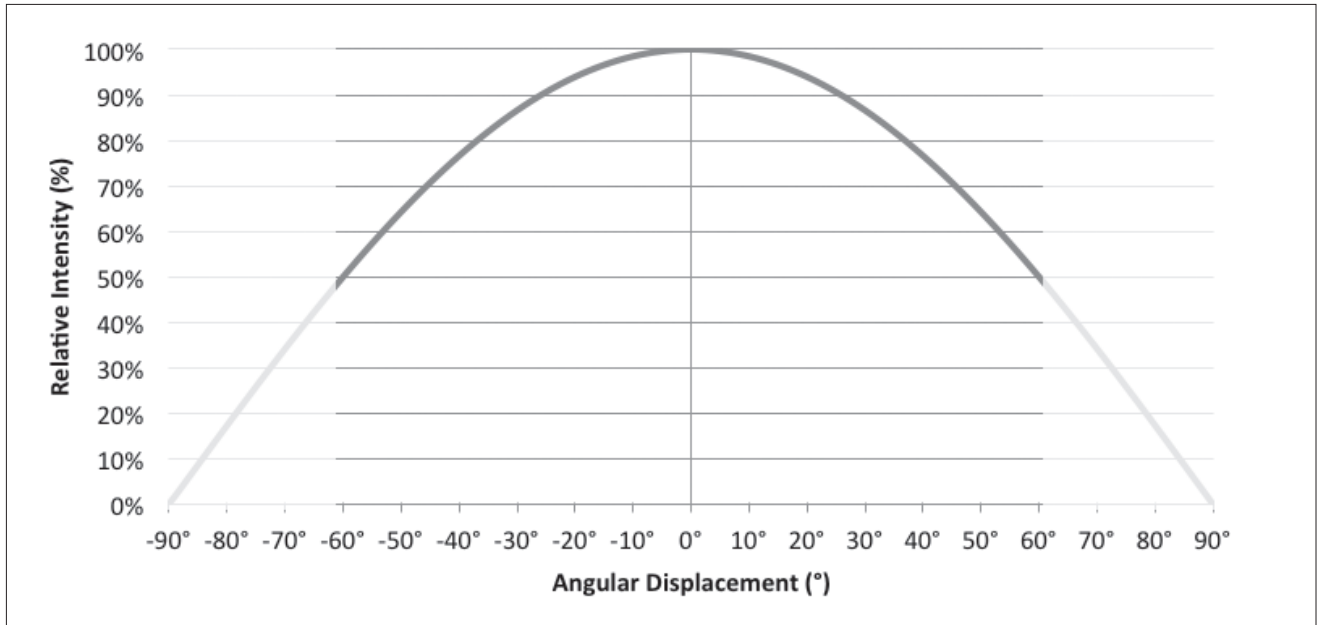

Notes for Figure 9:

1. Typical viewing angle is 120°.
2. The viewing angle is defined as the off axis angle from the centerline where intensity is ½ of the peak value.

Figure 10: Typical Polar Radiation Pattern

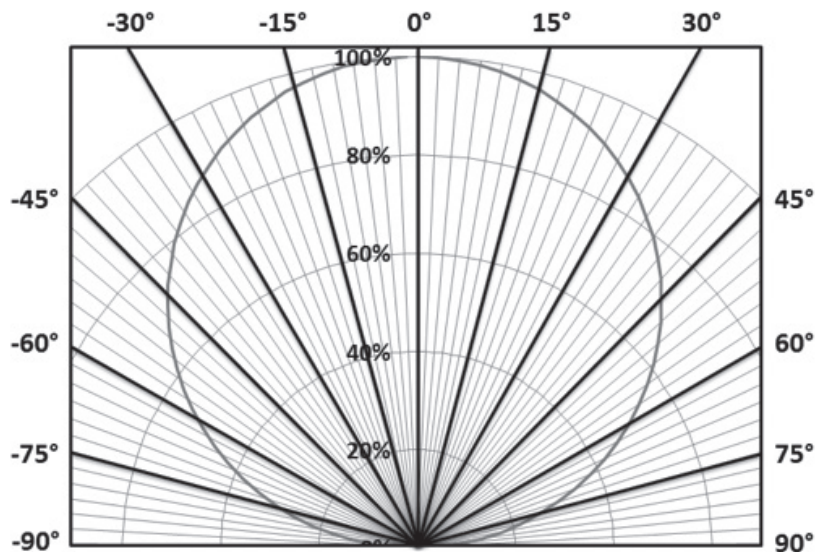

Typical Color Spectrum

Figure 11: Typical Color Spectrum

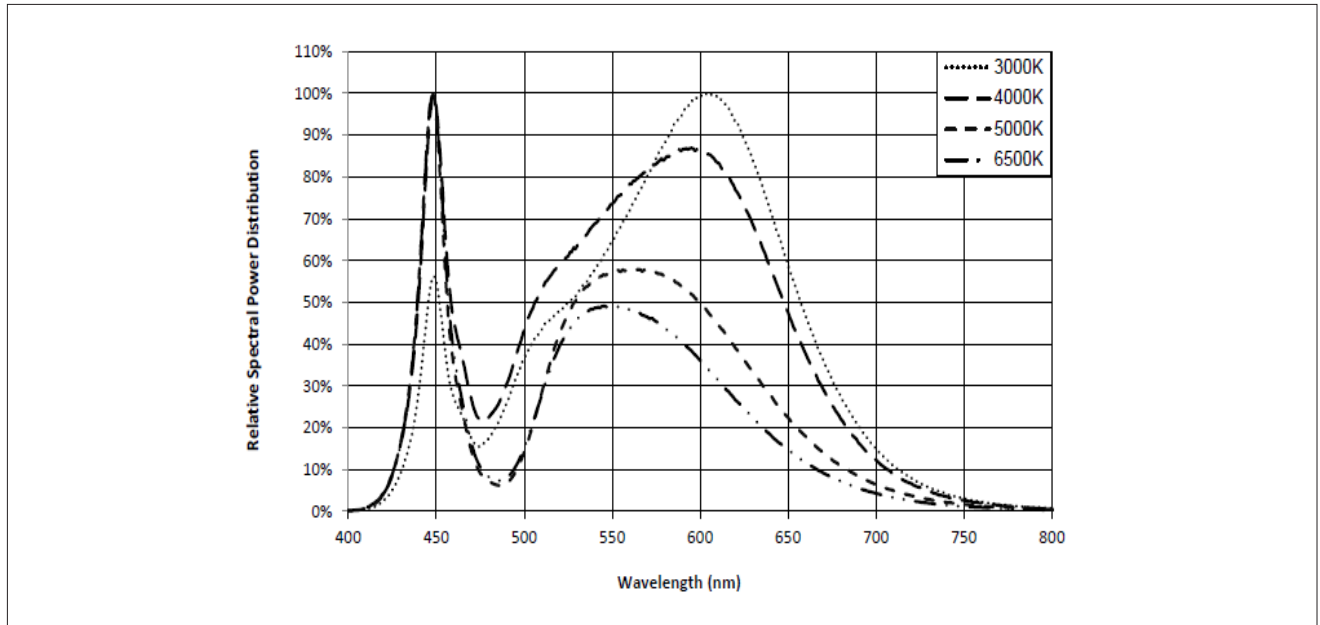

Notes for Figure 11:

1. Color spectra measured at nominal current for $T_J - T_C = 25^\circ\text{C}$.
2. Color spectra shown is 3000K and 80 CRI.
3. Color spectra shown is 4000K and 80 CRI.
4. Color spectra shown is 5000K and 70 CRI.
4. Color spectra shown is 6500K and 70 CRI.

Operating Limits

Figure 12: Operating Limits

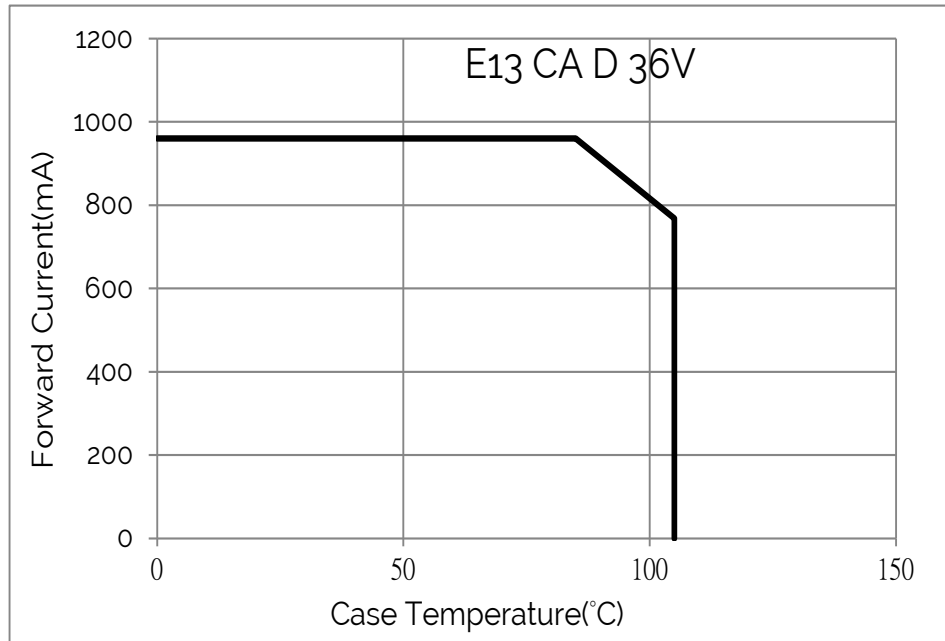
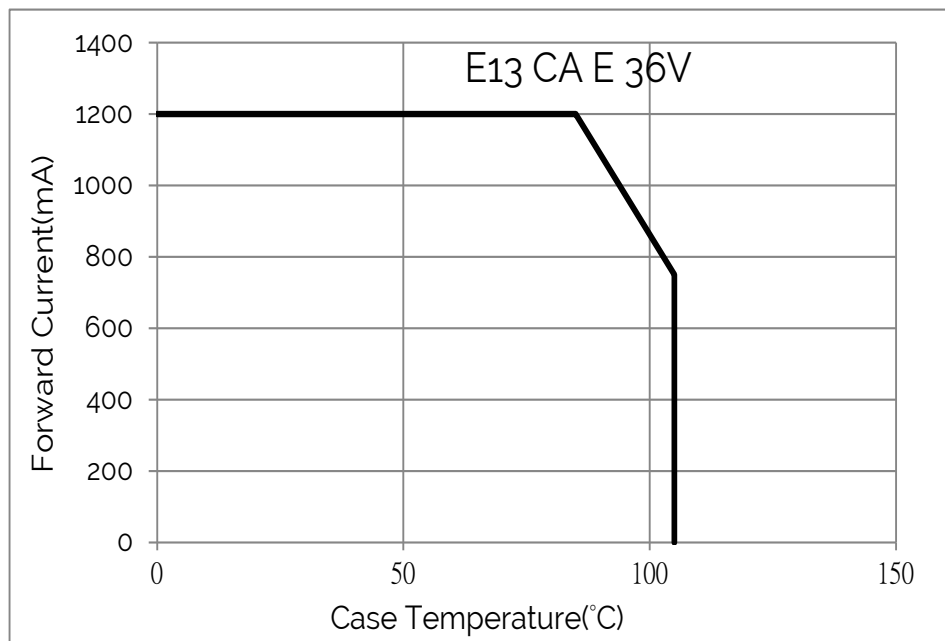

Figure 13: Operating Limits



Color Binning Information

Table 7: xy Bin Coordinates and Associated Typical CCT

CCT	Center Point		Degree	3 step		4 step	
	x	y	(°)	a	b	a	b
2700K	0.4578	0.4101	53.700	0.0081	0.0042	N/A	N/A
3000K	0.4338	0.403	53.217	0.0083	0.0041	N/A	N/A
3500K	0.4073	0.3917	54.000	0.0093	0.0041	N/A	N/A
4000K	0.3818	0.3797	53.717	0.0094	0.0040	N/A	N/A
5000K	0.3447	0.3553	59.617	N/A	N/A	0.0110	0.0047
5600K	0.3287	0.3417	59.060	N/A	N/A	0.0099	0.0042
6500K	0.3123	0.3282	58.567	N/A	N/A	0.0089	0.0038

Notes for Table 6:

- 2700K \3000K\3500K\4000K product is cold targeted to $T_c = 25^\circ\text{C}$
- 5000K \5600K\6500K product is hot targeted to $T_c = 85^\circ\text{C}$

Figure 14: Graph of Test Bins in xy Color Space

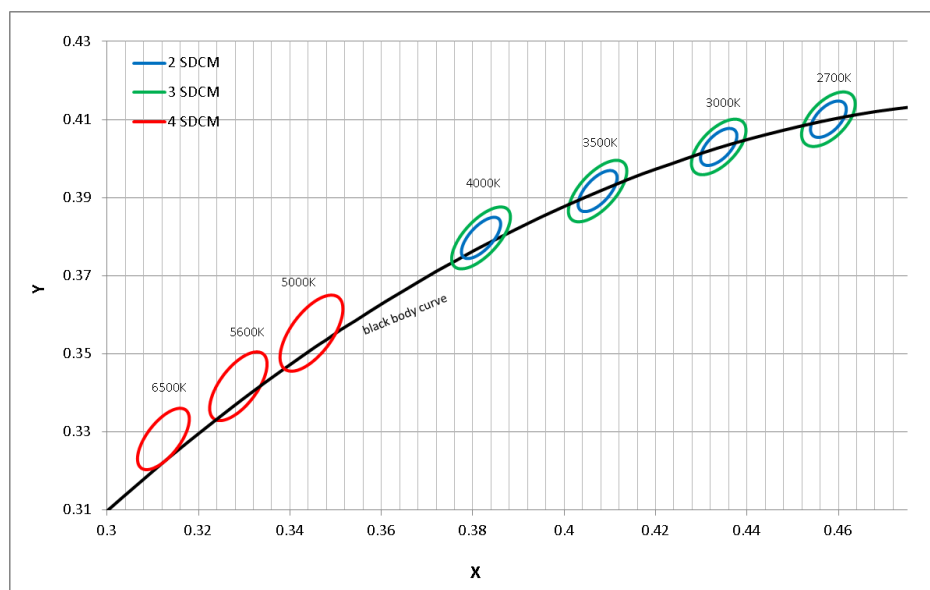

Notes for Figure 14:

- DC Test Conditions at $T_c = 85^\circ\text{C}$.
- Bridgelux maintains a tolerance of ± 0.007 on x and y color coordinates in the CIE 1931 color space.

Mechanical Dimensions

Figure 15: Drawing for E Series E13 CA LED Array

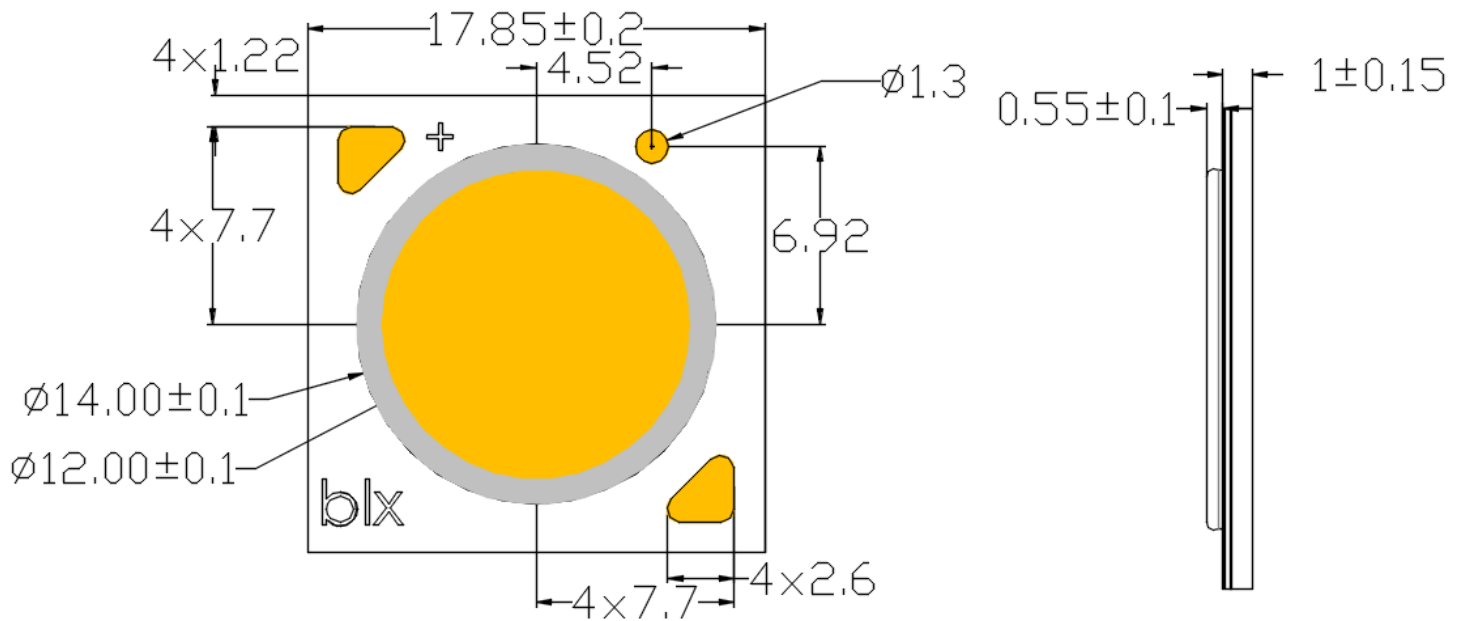

Notes for Figure 15:

1. Bridgelux maintains a flatness of 0.10mm across the mounting surface of the array
2. Drawings are not to scale.
3. Drawing dimensions are in millimeters.
4. Unless otherwise specified, tolerances are ±0.13mm.
5. Solder pad labeled "+" denotes positive contact.
6. The optical center of the LED Array is nominally defined by the mechanical center of the array to a tolerance of ± 0.2mm.

Packaging and Labeling

Figure 16: Packaging and Labeling



Packaging and Labeling

Figure 17: Laser Marking

Bridgelux COB arrays have laser markings on the back side of the substrate to help with product identification. In addition to the product identification markings, Bridgelux COB arrays also contain markings for internal Bridgelux manufacturing use only. The image below shows which markings are for customer use and which ones are for Bridgelux internal use only. The Bridgelux internal manufacturing markings are subject to change without notice, however these will not impact the form, function or performance of the COB array.



Customer Use- 2D Barcode Scannable barcode provides product part number and other Bridgelux internal production information.

30E3000D 13 — Customer Use- Product part number

Design Resources

LM80

Please contact your Bridgelux sales representative for more information.

Precautions

CAUTION: CHEMICAL EXPOSURE HAZARD

Exposure to some chemicals commonly used in luminaire manufacturing and assembly can cause damage to the LED array. Please consult Bridgelux Application Note AN31 for additional information.

CAUTION: EYE SAFETY

The Bridgelux Dual Color LED Array emits visible light, that, under certain circumstances, could be harmful to the eye. Proper safeguards must be used.

CAUTION: RISK OF BURN

Do not touch the Bridgelux Dual Color LED array during operation. Allow the array to cool for a sufficient period of time before handling. The Bridgelux Dual Color LED array may reach elevated temperatures such that could burn skin when touched

CAUTION

CONTACT WITH LIGHT EMITTING SURFACE (LES)

Avoid any contact with the LES. Do not touch the LES of the LED array or apply stress to the LES (yellow phosphor resin area). Contact may cause damage to the LED array.

Optics and reflectors must not be mounted in contact with the LES (yellow phosphor resin area). Use the mechanical features of the LED array housing, edges and/or mounting holes to locate and secure optical devices as needed.

Disclaimers

MINOR PRODUCT CHANGE POLICY

The rigorous qualification testing on products offered by Bridgelux provides performance assurance. Slight cosmetic changes that do not affect form, fit, or function may occur as Bridgelux continues product optimization.

STANDARD TEST CONDITIONS

Unless otherwise stated, array testing is performed at the nominal drive current.

About Bridgelux: Bridging Light and Life™

At Bridgelux, we help companies, industries and people experience the power and possibility of light. Since 2002, we've designed LED solutions that are high performing, energy efficient, cost effective and easy to integrate. Our focus is on light's impact on human behavior, delivering products that create better environments, experiences and returns—both experiential and financial. And our patented technology drives new platforms for commercial and industrial luminaires.

For more information about the company, please visit
bridgelux.com
twitter.com/Bridgelux
facebook.com/Bridgelux
youtube.com/user/Bridgelux
linkedin.com/company/bridgelux-inc-_2
WeChat ID: BridgeluxInChina



46410 Fremont Boulevard
Fremont, CA 94538 USA
Tel (925) 583-8400
Fax (925) 583-8401
www.bridgelux.com

© 2022 Bridgelux, Inc. All rights reserved. Product specifications are subject to change without notice. Bridgelux and the Bridgelux stylized logo design are registered trademarks of Bridgelux, Inc. All other trademarks are the property of their respective owners.