



Bridgelux[®] 50W Dual Channel Driver

Product Data Sheet DS 450



Introduction

The Bridgelux 50W Dual Channel Driver enables control of correlated color temperature (CCT) tunable and intensity dimmable LED sources. A high resolution dimming and tuning algorithm provides for smooth and flicker free dimming and CCT tuning characteristics. Dual 0-10V and IoT-Ready™ control inputs enable interoperability with industry standard lighting devices and controls. The Driver's dual channel output integrates seamlessly with Bridgelux Vesta® Series Tunable White arrays and modules. The Driver's unique design makes it ideal for commercial troffer and linear lighting applications.

Separate control modules connect to the driver via its dual 0-10V and IoT-Ready inputs. When paired with Bridgelux's optional Bluetooth control module (sold separately), the driver may be controlled with Bridgelux's Lighting Control application for light commissioning and management of large installations. The Bridgelux Lighting Control application is available in iOS and Android.

Features

- Class 2 dual channel driver
- 120-277VAC/50-60Hz input voltage, low inrush currents, high efficiencies, low THD, high power factors
- 0.7A to 1.4A drive current per channel, adjustable via DIP switches
- High resolution dimming and tuning curves
- Each channel is dimmable to 3%, dim to off
- IoT-Ready and dual 0-10V control input for intensity dimming and CCT tuning
- Auxiliary power output for sensors and controls
- Energy monitoring via IoT-Ready Profile 1 interface
- Built-in overvoltage, over-temperature and short circuit protection
- 50,000 hour design life with 5-year limited warranty

Benefits

- Compatible with industry standard electrical specification requirements
- Optimized for operation with Bridgelux Vesta® Tunable White arrays and modules
- Smooth, flicker free dimming and CCT tuning
- Linear and logarithmic dim curves
- Dimming to low light levels
- Dimming curve options to match preference and industry control standards
- Interoperable with a large ecosystem of IoT-Ready and 0-10V devices and controls
- Remote management of lighting control, energy consumption and system health
- Reliable, maintenance-free operation in demanding operating conditions over long periods of time

Contents

Product Feature Map	2
Product Nomenclature, Product Selection Guide	2
Electrical Characteristics	3
Control Characteristics	4
Output Characteristics	5
Terminal Configuration	6
Mechanical Characteristics	7
Environmental and Regulatory Standards	8
Packaging and Labeling	9
Design Resources	10
Precautions	10
Disclaimers	10
About Bridgelux	11

Product Feature Map

Bridgelux's 50W Dual Channel Driver is a fully engineered device that provides two dynamic constant current outputs for dual channel CCT tunable LED modules and arrays. The design of this driver allows for simple integration and interoperability with industry standard lighting systems and protocols. Please visit www.bridgelux.com for more information on the 50W Dual Channel Driver and compatible Vesta Series Tunable White arrays and modules.

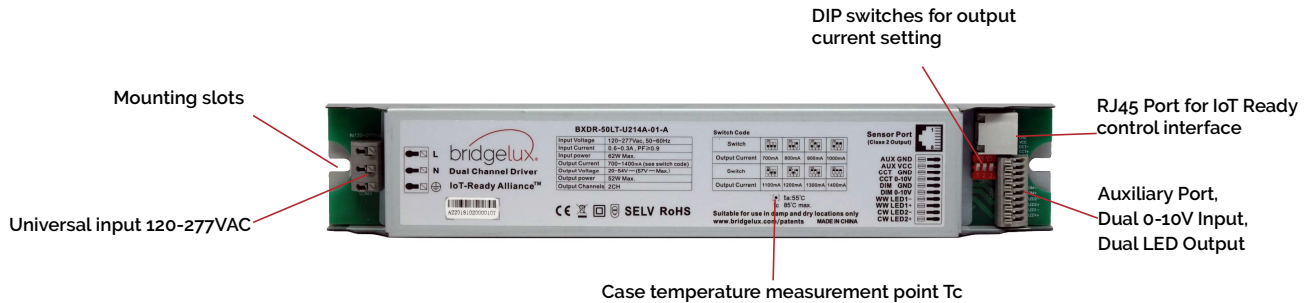

Product Nomenclature

The part number designation for Bridgelux 50W Dual Channel Driver is explained as follows:

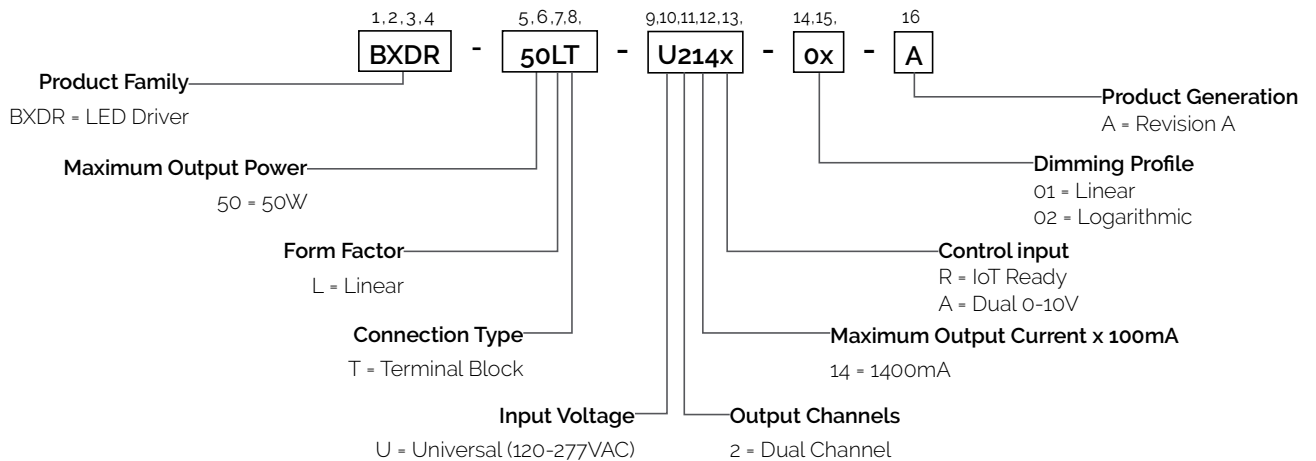

Table 1: Product Selection Guide

Part Number	Control Input	Dimming Profile
BXDR-50LT-U214R-01-A	IoT-Ready	Linear
BXDR-50LT-U214R-02-A	IoT-Ready	Logarithmic
BXDR-50LT-U214A-01-A	Dual 0-10V	Linear
BXDR-50LT-U214A-02-A	Dual 0-10V	Logarithmic

Note:

Control input and Dimming Profiles are pre-programmed and cannot be changed in the field.

Electrical Characteristics

Table 2: Main Electrical Characteristics

Parameter	Specification
Input Voltage	120VAC to 277VAC +/-10%
Input Power	62W (max)
Input Current	0.6A (max)
Inrush Current	Beneath NEMA 410-2011 limit
Surge Protection	2kV per EN 61547: 2009 (IEC 61000-4-5: 2006)
ESD Rating	Class 3A, HBM
Power Factor	0.99 at 120VAC/220VAC/240VAC, 0.98 at 277VAC (typical at max load)
Efficiency	84% at 120VAC, 86.5% at 220VAC/240VAC/277VAC (typical at max load)
Total Harmonic Distortion (THD)	7.5% at 120VAC, 11.7% at 220VAC, 11.9% at 240VAC, 12.1% at 277VAC (typical at max load)
Standby Power	<0.7W at 120VAC, <1W at 277VAC (0-10V controls idling, LEDs commanded to off; When used with an IoT-Ready device, the standby power depends on the device's power ratings and data traffic)

Figure 1: Power Factor vs. Output Power

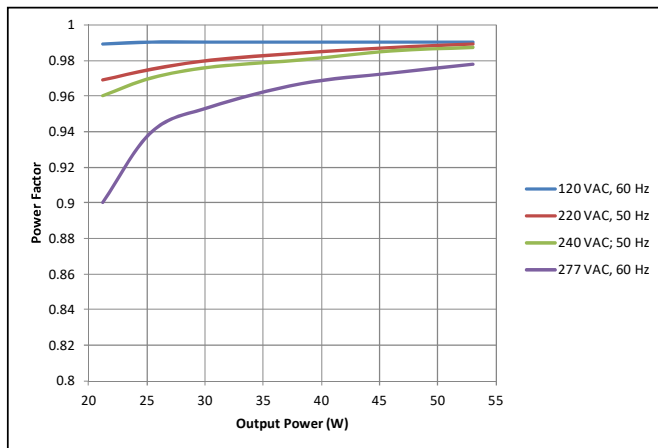

Figure 2: Efficiency vs. Output Power

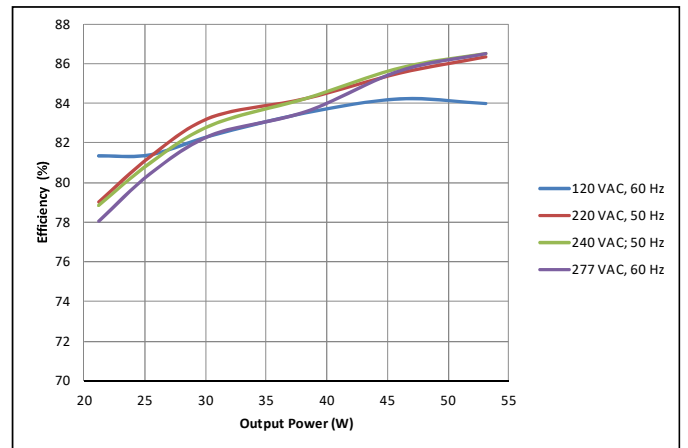
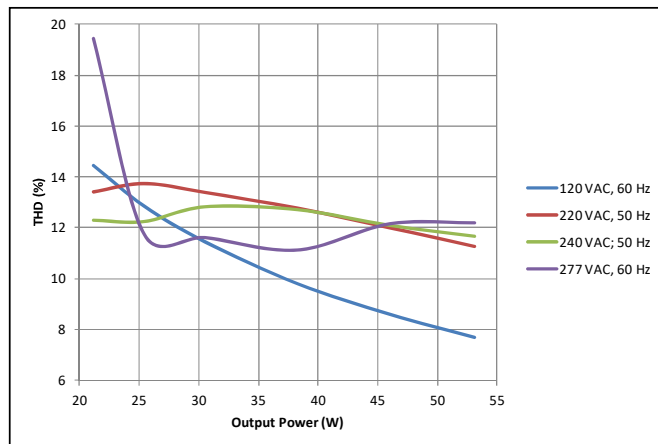

Figure 3: THD vs Output Power



Notes for Figure 1, 2 and 3:

Graphs represent typical performance at an ambient temperature of 25C. The driver was tested with a 52W maximum LED load. Testing at output power levels below the 52W maximum was performed by dimming the light output.

Control Characteristics

Table 3: Control Options

Control Option	Control Input	Specification
IoT-Ready	IoT-Ready Alliance, Intensity Dimming, CCT Tuning	IoT-Ready Alliance, Profile 1
Dual 0-10V	Dual 0-10V, Intensity Dimming, CCT Tuning	ANSI E13, IEC 60929 Annex E

Table 4: Dimming Range

Parameter	Specification
Dimming Range	100% - 3%; dim to off

Figure 4: Linear Dimming Curve

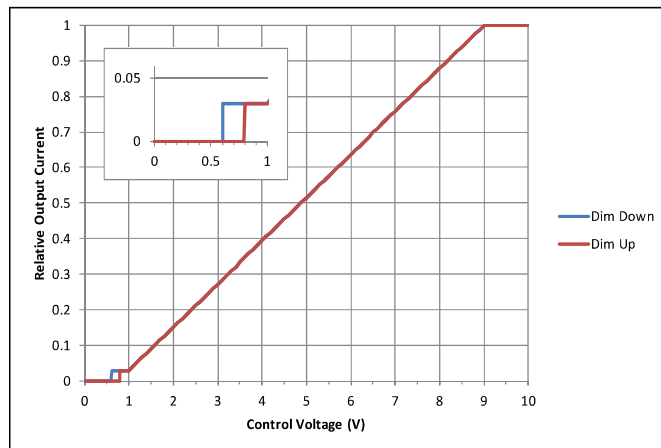

Figure 5: Logarithmic Dimming Curve

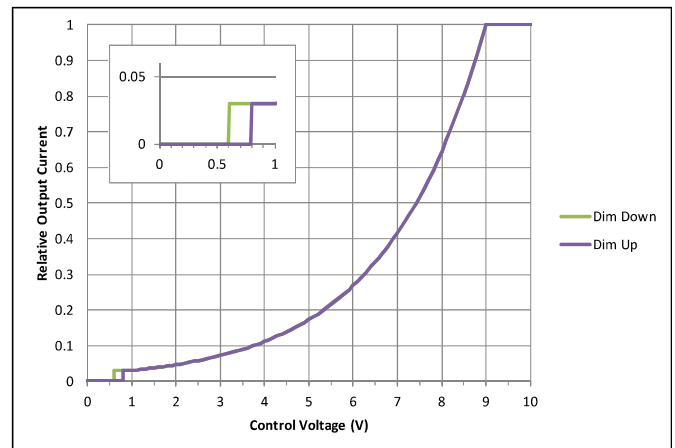
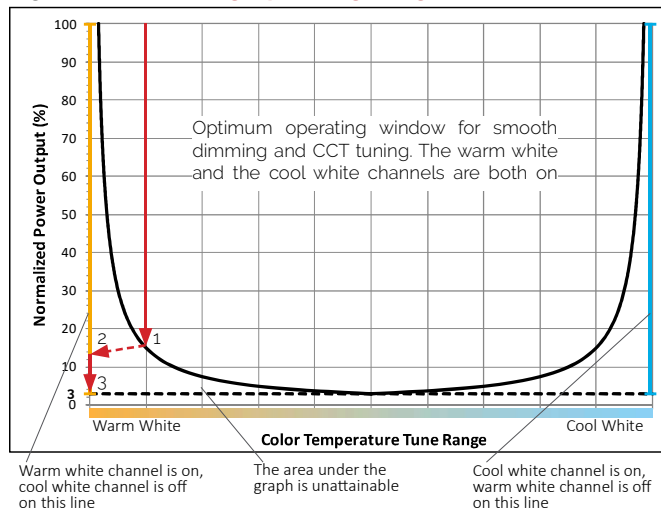

Figure 6: CCT Tuning Operating Range



Notes for Figure 6:

The graph represents the 3% low dimming limit of the driver's two output channels. Above this 3% line, both channels operate at a 3% or greater dimming level. Below the dotted line, both output channels turn off.

The red arrows show an example where the CCT is tuned to a specific warm white CCT at which the ratio of warm white output current to cool white output current is high. At this CCT, when the dimming level reaches 15% (1), the cool white output current reaches its 3% output current limit at which the cool white channel turns off while the warm white channel maintains its output current. As a result, the total light output drops by 3% and the CCT shifts to the warm white CCT limit (2). When the dimming level reaches 3%, then the warm white channel turns off also (3). For smooth dimming and CCT tuning performance, it is recommended to operate this driver above the 3% low dimming limit of each of the two output channels.

Output Characteristics

Table 5: Electrical Output

Parameter	Specification
Output Power	52W (max)
Output Voltage per Channel	20 - 54V DC
Current per Channel ¹	1400mA (max)
Current from both Output Channels combined ¹	1400mA (max)
Output Current Tolerance	+/-5% (max)
Output Ripple	<2% at 120VAC
Auxiliary Power	12VDC, 50mA (max)
Short Circuit Protection	A short between output terminals results in no output power and an auto reset
Over-Temperature Protection	75% output current at case temperature $T_c > 85^\circ\text{C}$
	Zero output current at case temperature $T_c > 95^\circ\text{C}$
Startup Time	< 0.5s

Note for Table 5:

The 50W Dual Channel Driver has two independent output channels, one for cool white and one for warm white. Each channel generates up to 1400mA output current. The maximum combined current from both output channels is also 1400mA. Therefore when one channel generates a current of 1000mA, then the other channel is limited to a current of 400mA.

Figure 7: Output Current Operating Range

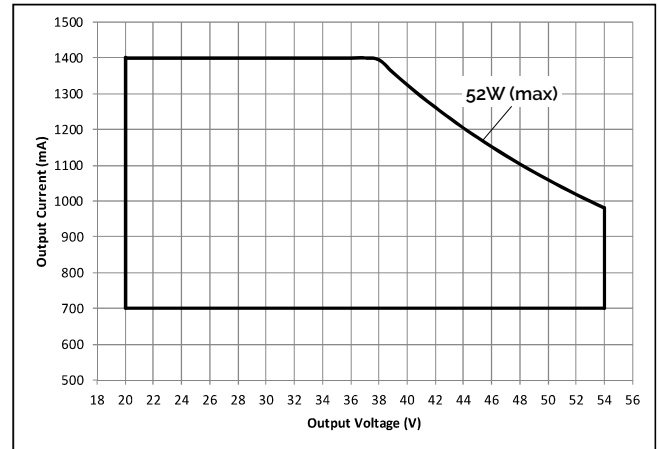

Table 6: DIP Switch Output Current Selections

Switch				
Output Current	700mA	800mA	900mA	1000mA
Switch				
Output Current	1100mA	1200mA	1300mA	1400mA

Note for Table 6:

The 50W Dual Channel Driver DIP switch allows for selecting maximum output currents ranging from 700mA to 1400mA per channel. The maximum combined current from both output channels is equal to the selected current on the DIP switch. When a maximum current of 1000mA is selected, then the maximum combined current from both channels is 1000mA. Therefore when one channel generates a current of 600mA, then the other channel is limited to a current of 400mA.

Table 7: Flicker Specifications

Specification	Performance
IEEE P1789	Compliant with "No Effect" Region
NEMA 77-2017	Compliant
CEC Title 24 JA8	<30% for frequencies of 200Hz or below at 100% and 20% light output

Terminal Configuration

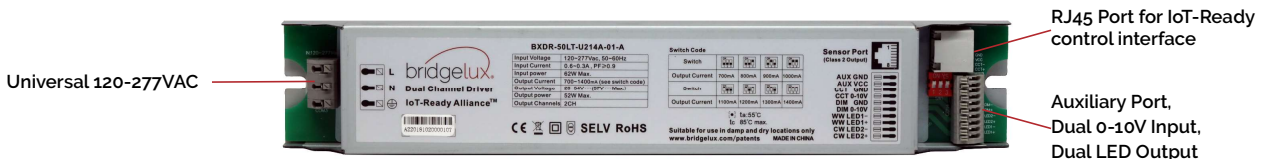

Table 8: Terminal Configuration

Feature	Universal 120 - 277VAC Terminal	Dual 0-10V Input Control, Dual LED Output, and Auxiliary Power Terminal	IoT-Ready Control Terminal
Connector Type	Poke-In Terminal Block with Release	Poke-In Terminal Block with Release	RJ45 Terminal Block
AWG Wire Size	12 - 20	20 - 24	n.a.
Wire Type	Solid Core or Fine-Stranded Tinned	Solid Core or Fine-Stranded Tinned	CAT5/CAT5e/CAT6/CAT6e cable
Wire Strip Length	9mm +/-1mm	9mm +/-1mm	n.a.
Terminal Picture			

Note for Table 8:
Driver must be grounded in accordance with local and national electrical codes.

Mechanical Characteristics

Table 9: Driver Mechanical Characteristics

Properties	Specification
Dimensions	280mm (L) x 48mm (W) x 32.5mm (H)
Enclosure Material	Metal
Weight	0.46kg / 1lbs
Ingress Protection	IP20

Figure 8: Mechanical Drawing

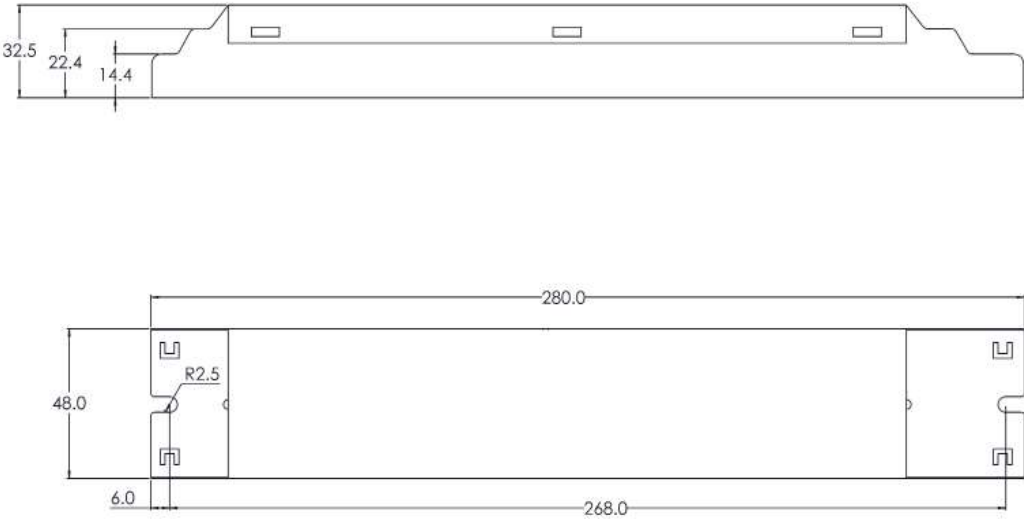

- Notes for Figure 8:
1. Drawings are not to scale
 2. Drawing dimensions are in millimeters
 3. Unless otherwise specified, all linear tolerances are +/-1.0mm
 4. Use #10 or M5 fastener in the mounting slots for anchoring the driver in position

Environmental and Regulatory Standards

Table 10: Environmental Conditions

Parameter	Specification
Case Temperature, Tc	+75°C (max)
Ambient Operating Temperature	-20°C to +45°C
Humidity Ratings	Maximum 85% Relative Humidity, non condensing
Operating Environment	For indoor use only
Storage Temperature	-20°C to +70°C

Regulatory Approvals and Compliance

- UL 8750, Rated for dry and damp locations,
- Type TL LED driver
- Category FKSZ2, file number E506581 (Class 2)
- FCC Part 15B, Class B
- EN 61347-2-13:2014 + A1:2017 (safety)
- EN 55015:2013 (EMC)
- EN 61547:2009 (EMC)
- EN 61000-3-2:2014 (EMC)
- EN 61000-3-3:2013 (EMC)
- RoHS 3

Packaging

Table 11: Packaging Configuration

	Tray	Box	Pallet
Quantity	5 Drivers	25 Drivers	1125 Drivers in 45 Boxes
Weight	2.25kg	11.25kg net / 14.5kg gross	669kg gross (including base)

Figure 9: Tray Design

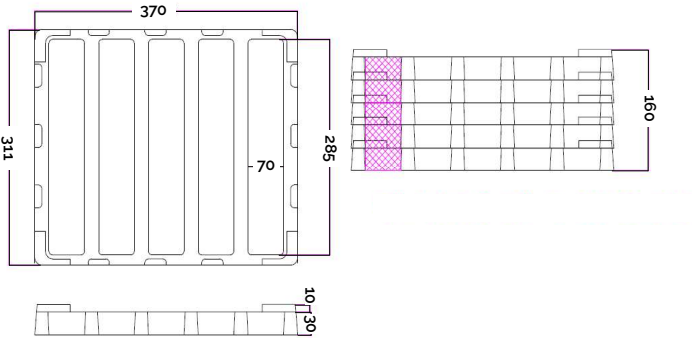
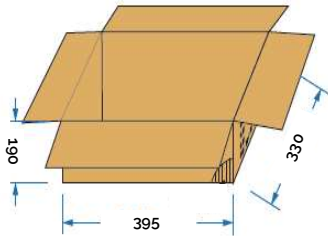

Figure 10: Packaging Box Design



Design Resources

Application Notes

Please contact your Bridgelux sales representative for assistance on obtaining application support when designing with the Bridgelux 50W Dual Channel Driver. For a list of available resources, visit www.bridgelux.com.

3D CAD Models

CAD models depicting the 50W Dual Channel Driver are available in both IGES and STEP formats. Please contact your Bridgelux sales representative for assistance.

Precautions

CAUTION: PRODUCT HANDLING

Handle the 50W Dual Channel Driver with care to prevent any damage from mechanical shock

It is recommended to handle this driver in a static-free environment, e.g., wear antistatic wrist bands

Do not open or disassemble the product

Do not exceed the specified maximum humidity and temperature conditions

To maintain product warranty, the installer is responsible for ensuring that the driver's operating conditions do not exceed the maximum conditions stated within this data sheet

CAUTION: PRODUCT INSTALLATION

Incorrect installation of the 50W Dual Channel Driver can cause irreparable damage to the driver, connected LEDs or connected control devices.

Pay attention when connecting the LED load and observe the correct polarity of the output terminals as specified in this data sheet and on the driver label.

WARNING: ELECTRIC SHOCK

Be aware of the possibility of an electric shock hazard which can result in serious injury or death. Disconnect power before servicing or installing this device.

Disclaimers

MINOR PRODUCT CHANGE POLICY

The rigorous qualification testing on products offered by Bridgelux provides performance assurance. Slight cosmetic changes that do not affect form, fit, or function may occur as Bridgelux continues product optimization.

About Bridgelux: Bridging Light and Life™

At Bridgelux, we help companies, industries and people experience the power and possibility of light. Since 2002, we've designed LED solutions that are high performing, energy efficient, cost effective and easy to integrate. Our focus is on light's impact on human behavior, delivering products that create better environments, experiences and returns—both experiential and financial. And our patented technology drives new platforms for commercial and industrial luminaires.

For more information about the company, please visit

bridgelux.com

twitter.com/Bridgelux

facebook.com/Bridgelux

youtube.com/user/Bridgelux

linkedin.com/company/bridgelux-inc-_2

WeChat ID: BridgeluxInChina



46430 Fremont Blvd
Fremont, CA 94538 USA
Tel (925) 583-8400
www.bridgelux.com