



# Bridgelux® Gen. 7 V15 Array

Product Data Sheet DS106



# Introduction

V Series



The V Series LED array products deliver high quality light in a compact and cost-effective solid-state lighting package. These Chip-on-Board (CoB) arrays can be efficiently driven at twice the nominal drive current, enabling design flexibility not previously possible. This high flux density light source is designed to support a wide range of high quality, low cost directional luminaires and replacement lamps for commercial and residential applications.

The V15 LED array is available in a variety of electrical, CCT and CRI combinations providing substantial design flexibility and energy efficiencies.

Lighting system designs incorporating these LED arrays deliver comparable performance to 35 Watt ceramic metal halide based luminaires, delivering increased system level efficacy and longer service life. Typical applications include, but are not limited to, replacement lamps, task, accent, spot, track, down light, wide area, security, and wall pack.

## Features

- Efficacy of 150 lm/W typical at 3000K, 80 CRI
- Compact high flux density light source
- Uniform high quality illumination
- Minimum 80 and 90 CRI options
- Streamlined thermal path
- Energy Star / ANSI compliant color binning structure with 2 SDCM standard
- More energy efficient than incandescent, halogen and fluorescent lamps
- Low voltage DC operation
- Instant light with unlimited dimming

## Benefits

- Enhanced optical control
- Clean white light without pixelation
- High quality true color reproduction
- Significantly reduced thermal resistance and increased operating temperatures
- Uniform consistent white light
- Lower operating costs
- Easy to use with daylight and motion detectors to enable increased energy savings
- Reduced maintenance costs
- Environmentally friendly, no disposal issue



# Contents

Product Feature Map	2
Product Nomenclature	2
Product Selection Guide	3
European Product Registry for Energy Labeling	4
Performance at Commonly Used Drive Currents	5
Electrical Characteristics	7
Eye Safety	8
Absolute Maximum Ratings	9
Performance Curves	10
Typical Radiation Pattern	11
Typical Color Spectrum	12
Mechanical Dimensions	13
Color Binning Information	14
Packaging and Labeling	15
Design Resources	17
Precautions	17
Disclaimers	17
About Bridgelux	18

# Product Feature Map

Bridgelux arrays are fully engineered devices that provide consistent thermal and optical performance on an engineered mechanical platform. The V Series arrays are

the most compact chip-on-board devices across all of Bridgelux's LED Array products. The arrays incorporate several features to simplify design integration and assembly.

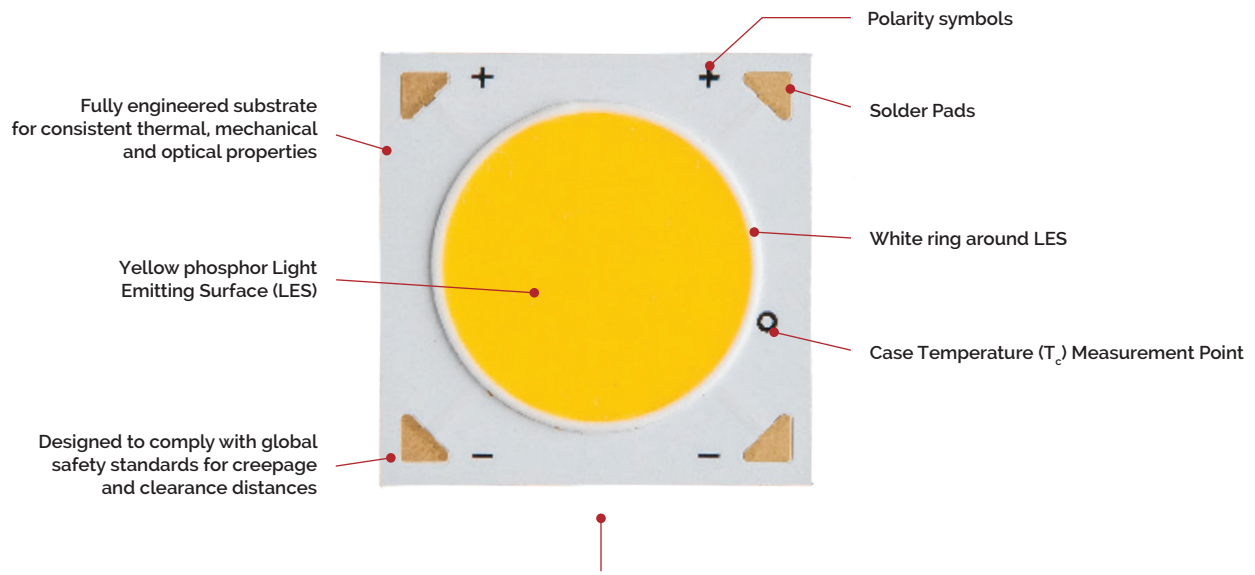

Note: Part number and lot codes are scribed on back of array

## Product Nomenclature

The part number designation for Bridgelux V Series LED arrays is explained as follows:

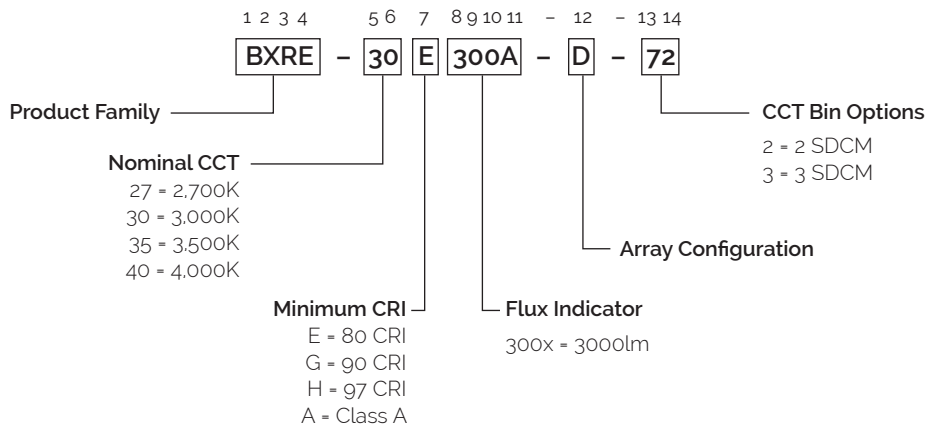

# Product Selection Guide

The following product configurations are available:

**Table 1:** Selection Guide, Pulsed Measurement Data ( $T_j = T_c = 25^\circ\text{C}$ )

Part Number	Nominal CCT <sup>1</sup> (K)	CRI <sup>2</sup>	Nominal Drive Current <sup>3</sup> (mA)	Typical Pulsed Flux <sup>4,5,6</sup> $T_c = 25^\circ\text{C}$ (lm)	Minimum Pulsed Flux <sup>6,7</sup> $T_c = 25^\circ\text{C}$ (lm)	Typical $V_f$ (V)	Typical Power (W)	Typical Efficacy (lm/W)
BXRE-27E300A-D-7x	2700	80	700	3498	3218	34.1	23.9	147
BXRE-27G300A-D-7x	2700	90	700	2915	2682	34.1	23.9	122
BXRE-27H300A-D-7x	2700	95	700	2519	2318	34.1	23.9	106
BXRE-30E300A-D-7x	3000	80	700	3644	3353	34.1	23.9	153
BXRE-30G300A-D-7x	3000	90	700	3024	2782	34.1	23.9	127
BXRE-30H300A-D-7x	3000	95	700	2706	2490	34.1	23.9	113
BXRE-35E300A-D-7x	3500	80	700	3750	3450	34.1	23.9	157
BXRE-35G300A-D-7x	3500	90	700	3134	2883	34.1	23.9	131
BXRE-35A3001-D-7x	3500	93	700	3036	2793	34.1	23.9	127
BXRE-40E300A-D-7x	4000	80	700	3789	3486	34.1	23.9	159
BXRE-40G300A-D-7x	4000	90	700	3242	2983	34.1	23.9	136
BXRE-40A3001-D-7x	4000	93	700	3244	2984	34.1	23.9	136

**Table 2:** Selection Guide, Stabilized DC Performance ( $T_c = 85^\circ\text{C}$ )<sup>8,9</sup>

Part Number	Nominal CCT <sup>1</sup> (K)	CRI <sup>2</sup>	Nominal Drive Current <sup>3</sup> (mA)	Typical DC Flux $T_c = 85^\circ\text{C}$ (lm)	Minimum DC Flux <sup>10</sup> $T_c = 85^\circ\text{C}$ (lm)	Typical $V_f$ (V)	Typical Power (W)	Typical Efficacy (lm/W)
BXRE-27E300A-D-7x	2700	80	700	3183	2929	33.1	23.2	137
BXRE-27G300A-D-7x	2700	90	700	2653	2441	33.1	23.2	115
BXRE-27H300A-D-7x	2700	95	700	2293	2109	33.1	23.2	99
BXRE-30E300A-D-7x	3000	80	700	3316	3051	33.1	23.2	143
BXRE-30G300A-D-7x	3000	90	700	2752	2532	33.1	23.2	119
BXRE-30H300A-D-7x	3000	95	700	2463	2266	33.1	23.2	106
BXRE-35E300A-D-7x	3500	80	700	3412	3139	33.1	23.2	147
BXRE-35G300A-D-7x	3500	90	700	2852	2624	33.1	23.2	123
BXRE-35A3001-D-7x	3500	93	700	2763	2542	33.1	23.2	119
BXRE-40E300A-D-7x	4000	80	700	3448	3172	33.1	23.2	149
BXRE-40G300A-D-7x	4000	90	700	2951	2714	33.1	23.2	127
BXRE-40A3001-D-7x	4000	93	700	2952	2716	33.1	23.2	127

Notes for Tables 1 & 2:

- Nominal CCT as defined by ANSI C78.377-2011.
- All CRI values are measured at  $T_j - T_c = 25^\circ\text{C}$ . CRI values are typical for Decor Series Ultra, Décor Series Street and Landmark and Decor Series Class A products. CRI values are minimums for all other products. Minimum Rg value for 80 CRI products is 0. Minimum Rg value is 60 for 90 CRI products on 2700K/3000K/3500K and 4000K, it is 50 on 5000K/5700K and 6500K. But for the CRI90 Ho products (higher efficiency CRI90 version), minimum Rg value is 55 on 2700K/3000K/3500K and 4000K. Minimum Rg value for 97 CRI products is 93 on 2700K and 3000K, and it is 85 on 3500K /4000K/5000K and 5700K. Bridgelux maintains a  $\pm 3$  tolerance on Rg values.
- Drive current is referred to as nominal drive current.
- Products tested under pulsed condition (10ms pulse width) at nominal test current where  $T_j$  (junction temperature) -  $T_c$  (case temperature) =  $25^\circ\text{C}$ .
- Typical performance values are provided as a reference only and are not a guarantee of performance.
- Bridgelux maintains a  $\pm 7\%$  tolerance on flux measurements.
- Minimum flux values at the nominal test current are guaranteed by 100% test.
- Typical stabilized DC performance values are provided as reference only and are not a guarantee of performance.
- Typical performance is estimated based on operation under DC (direct current) with LED array mounted onto a heat sink with thermal interface material and the case temperature maintained at  $85^\circ\text{C}$ . Based on Bridgelux test setup, values may vary depending on the thermal design of the luminaire and/or the exposed environment to which the product is subjected.
- Minimum flux values at elevated temperatures are provided for reference only and are not guaranteed by 100% production testing. Based on Bridgelux test setup, values may vary depending on the thermal design of the luminaire and/or the exposed environment to which the product is subjected.

# European Product Registry for Energy Labeling

The European Product Registry for Energy Labeling (EPREL) is defined in the EU Regulation 2017/1369 to provide important energy efficiency information to consumers. Together with Energy Labeling Regulation ELR (EU) 2019/2015 which was amended by regulation (EU) 2021/340 for energy labelling of light sources, manufacturers are required to declare an energy class based on key technical specifications from each of their product and register it in an open data base managed by EPREL. It is now a legal requirement for a vendor of light sources to upload information about their products into the EPREL database before placing these products on the market in the EU.

Table 3 below provides a list of part numbers that are in compliance with ELR and are currently listed in the EPREL database.

At Bridgelux, we are fully committed to supplying products that are compliant with pertinent laws, rules, and obligation imposed by relevant government bodies including the European Energy Labeling regulation. Customers can use these products with full confidence for any projects that fall under the ELR.

**Table 3:** Part numbers registered in European Product Registry for Energy Labeling

PART NUMBER <sup>1</sup>	CCT (K)	CRI	Current <sup>2</sup> (mA)	Vf (V)	Useful flux <sup>3</sup> ( $\Phi_{use}$ ) at 85C (lm)	Power (W)	Efficacy (lm/W)	Energy efficiency class <sup>4</sup>	Registration No	URL to Product Information Sheet in EPREL Database
BXRE-27E300A-D-7x	2700	80	1400	36.2	6155	50.6	122	E	869135	<a href="https://eprelec.europa.eu/qr/869135">https://eprelec.europa.eu/qr/869135</a>
BXRE-27G300A-D-7x	2700	90	1060	34.8	4019	36.9	109	F	869274	<a href="https://eprelec.europa.eu/qr/869274">https://eprelec.europa.eu/qr/869274</a>
BXRE-27H300A-D-7x	2700	95	750	33.6	2608	25.2	103	F	869367	<a href="https://eprelec.europa.eu/qr/869367">https://eprelec.europa.eu/qr/869367</a>
BXRE-30E300A-D-7x	3000	80	1400	36.2	6539	50.6	129	E	869566	<a href="https://eprelec.europa.eu/qr/869566">https://eprelec.europa.eu/qr/869566</a>
BXRE-30G300A-D-7x	3000	90	1220	35.5	4739	43.3	110	F	869716	<a href="https://eprelec.europa.eu/qr/869716">https://eprelec.europa.eu/qr/869716</a>
BXRE-30H300A-D-7x	3000	95	970	34.5	3520	33.5	105	F	869819	<a href="https://eprelec.europa.eu/qr/869819">https://eprelec.europa.eu/qr/869819</a>
BXRE-35E300A-D-7x	3500	80	1400	36.2	6693	50.6	132	E	869937	<a href="https://eprelec.europa.eu/qr/869937">https://eprelec.europa.eu/qr/869937</a>
BXRE-35G300A-D-7x	3500	90	1350	36.0	5335	48.6	110	F	870031	<a href="https://eprelec.europa.eu/qr/870031">https://eprelec.europa.eu/qr/870031</a>
BXRE-35A3001-D-7x	3500	90	1060	34.8	4019	36.9	109	F	869867	<a href="https://eprelec.europa.eu/qr/869867">https://eprelec.europa.eu/qr/869867</a>
BXRE-40E300A-D-7x	4000	80	1400	36.2	6732	50.6	133	E	870246	<a href="https://eprelec.europa.eu/qr/870246">https://eprelec.europa.eu/qr/870246</a>
BXRE-40G300A-D-7x	4000	90	1400	36.2	5616	50.6	111	F	870353	<a href="https://eprelec.europa.eu/qr/870353">https://eprelec.europa.eu/qr/870353</a>
BXRE-40A3001-D-7x	4000	90	1350	36.0	5335	48.6	110	F	870088	<a href="https://eprelec.europa.eu/qr/870088">https://eprelec.europa.eu/qr/870088</a>

Notes for Table 3:

1. All device listed here must be disposed as e-waste upon its end of life according to local country guideline in each country.
2. For information on performance values at alternative drive conditions, please refer to the Product Selection Guide, Absolute Maximum Rating Table and Performance Curves in this data sheet.
3. For a definition of useful luminous flux ( $\Phi_{use}$ ), please see the ELR regulations at <https://tinyurl.com/4b6zvt4m>.
4. EPREL requires an arrow symbol containing the letter of the energy efficiency class to be displayed, on technical promotional material. Refer to this energy efficiency class column for specific energy efficiency class on each part number.

# Performance at Commonly Used Drive Currents

V Series LED arrays are tested to the specifications shown using the nominal drive currents in Table 1. V Series may also be driven at other drive currents dependent on specific application design requirements. The performance at any drive current can be derived from the current vs. voltage characteristics shown in Figure 1 and the flux vs. current characteristics shown in Figure 2. The performance at commonly used drive currents is summarized in Table 4.

**Table 4:** Performance at Commonly Used Drive Currents

Part Number	CRI	Drive Current <sup>1</sup> (mA)	Typical $V_f$ $T_c = 25^\circ\text{C}$ (V)	Typical Power $T_c = 25^\circ\text{C}$ (W)	Typical Flux <sup>2</sup> $T_c = 25^\circ\text{C}$ (lm)	Typical DC Flux <sup>3</sup> $T_c = 85^\circ\text{C}$ (lm)	Typical Efficacy $T_c = 25^\circ\text{C}$ (lm/W)
BXRE-27E300A-D-7x	80	350	32.3	11.3	1804	1642	160
		525	33.2	17.4	2659	2419	152
		<b>700</b>	<b>34.1</b>	<b>23.9</b>	<b>3498</b>	<b>3183</b>	<b>147</b>
		1050	35.5	37.2	5059	4603	136
		1400	36.7	51.4	6515	5929	127
BXRE-27G300A-D-7x	90	350	32.3	11.3	1504	1368	133
		525	33.2	17.4	2216	2016	127
		<b>700</b>	<b>34.1</b>	<b>23.9</b>	<b>2915</b>	<b>2653</b>	<b>122</b>
		1050	35.5	37.2	4216	3837	113
		1400	36.7	51.4	5430	4941	106
BXRE-27H300A-D-7x	95	350	32.3	11.3	1299	1183	115
		525	33.2	17.4	1915	1742	110
		<b>700</b>	<b>34.1</b>	<b>23.9</b>	<b>2519</b>	<b>2293</b>	<b>106</b>
		1050	35.5	37.2	3643	3315	98
		1400	36.7	51.4	4692	4270	91
BXRE-30E300A-D-7x	80	350	32.3	11.3	1880	1711	166
		525	33.2	17.4	2770	2520	159
		<b>700</b>	<b>34.1</b>	<b>23.9</b>	<b>3644</b>	<b>3316</b>	<b>153</b>
		1050	35.5	37.2	5270	4796	142
		1400	36.7	51.4	6787	6177	132
BXRE-30G300A-D-7x	90	350	32.3	11.3	1560	1419	138
		525	33.2	17.4	2298	2091	132
		<b>700</b>	<b>34.1</b>	<b>23.9</b>	<b>3024</b>	<b>2752</b>	<b>127</b>
		1050	35.5	37.2	4373	3979	117
		1400	36.7	51.4	5632	5125	110
BXRE-30H300A-D-7x	95	350	32.3	11.3	1396	1270	124
		525	33.2	17.4	2057	1872	118
		<b>700</b>	<b>34.1</b>	<b>23.9</b>	<b>2706</b>	<b>2463</b>	<b>113</b>
		1050	35.5	37.2	3914	3562	105
		1400	36.7	51.4	5041	4587	98

Notes for Table 4:

1. Alternate drive currents in are provided for reference only and are not a guarantee of performance.
2. Bridgelux maintains a  $\pm 7\%$  tolerance on flux measurements.
3. Typical stabilized DC performance values are provided as reference only and are not a guarantee of performance.

# Performance at Commonly Used Drive Currents

**Table 4:** Performance at Commonly Used Drive Currents (continued)

Part Number	CRI	Drive Current <sup>1</sup> (mA)	Typical $V_f$ $T_c = 25^\circ\text{C}$ (V)	Typical Power $T_c = 25^\circ\text{C}$ (W)	Typical Flux <sup>2</sup> $T_c = 25^\circ\text{C}$ (lm)	Typical DC Flux <sup>3</sup> $T_c = 85^\circ\text{C}$ (lm)	Typical Efficacy $T_c = 25^\circ\text{C}$ (lm/W)
BXRE-35E300A-D-7x	80	350	32.3	11.3	1934	1760	171
		525	33.2	17.4	2850	2593	163
		<b>700</b>	<b>34.1</b>	<b>23.9</b>	<b>3750</b>	<b>3412</b>	<b>157</b>
		1050	35.5	37.2	5423	4935	146
		1400	36.7	51.4	6984	6355	136
BXRE-35G300A-D-7x	90	350	32.3	11.3	1616	1471	143
		525	33.2	17.4	2382	2167	137
		<b>700</b>	<b>34.1</b>	<b>23.9</b>	<b>3134</b>	<b>2852</b>	<b>131</b>
		1050	35.5	37.2	4532	4124	122
		1400	36.7	51.4	5836	5311	114
BXRE-40A3001-D-7x	93	350	32.3	11.3	1566	1425	139
		525	33.2	17.4	2307	2100	132
		<b>700</b>	<b>34.1</b>	<b>23.9</b>	<b>3036</b>	<b>2763</b>	<b>127</b>
		1050	35.5	37.2	4390	3995	118
		1400	36.7	51.4	5654	5146	110
BXRE-40E300A-D-7x	80	350	32.3	11.3	1954	1778	173
		525	33.2	17.4	2879	2620	165
		<b>700</b>	<b>34.1</b>	<b>23.9</b>	<b>3789</b>	<b>3448</b>	<b>159</b>
		1050	35.5	37.2	5479	4986	147
		1400	36.7	51.4	7056	6421	137
BXRE-40G300A-D-7x	90	350	32.3	11.3	1672	1522	148
		525	33.2	17.4	2464	2242	141
		<b>700</b>	<b>34.1</b>	<b>23.9</b>	<b>3242</b>	<b>2951</b>	<b>136</b>
		1050	35.5	37.2	4689	4267	126
		1400	36.7	51.4	6039	5495	118
BXRE-40A3001-D-7x	93	350	32.3	11.3	1673	1523	148
		525	33.2	17.4	2465	2243	141
		<b>700</b>	<b>34.1</b>	<b>23.9</b>	<b>3244</b>	<b>2952</b>	<b>136</b>
		1050	35.5	37.2	4691	4269	126
		1400	36.7	51.4	6041	5498	118

Notes for Table 4:

1. Alternate drive currents are provided for reference only and are not a guarantee of performance.
2. Bridgelux maintains a  $\pm 7\%$  tolerance on flux measurements.
3. Typical stabilized DC performance values are provided as reference only and are not a guarantee of performance.



# Electrical Characteristics

**Table 5:** Electrical Characteristics

Part Number	Drive Current (mA)	Forward Voltage Pulsed, $T_c = 25^\circ\text{C}$ (V) <sup>1, 2, 3</sup>			Typical Coefficient of Forward Voltage <sup>4</sup> $\Delta V_f / \Delta T$ (mV/ $^\circ\text{C}$ )	Typical Thermal Resistance Junction to Case <sup>5, 6</sup> $R_{j-c}$ (C/W)	Driver Selection Voltages <sup>7</sup> (V)	
		Minimum	Typical	Maximum			$V_f$ Min. Hot $T_c = 105^\circ\text{C}$ (V)	$V_f$ Max. Cold $T_c = -40^\circ\text{C}$ (V)
BXRE-xxx300x-D-7x	700	31.5	34.1	36.7	-17.7	0.19	30.1	37.9
	1400	33.5	36.2	38.9	-17.7	0.22	32.1	40.1

Notes for Table 5:

1. Parts are tested in pulsed conditions,  $T_c = 25^\circ\text{C}$ . Pulse width is 10ms.
2. Voltage minimum and maximum are provided for reference only and are not a guarantee of performance.
3. Bridgelux maintains a tester tolerance of  $\pm 0.10\text{V}$  on forward voltage measurements.
4. Typical coefficient of forward voltage tolerance is  $\pm 0.1\text{mV}$  for nominal current.
5. Thermal resistance values are based from test data of a 3000K 80 CRI product.
6. Thermal resistance value was calculated using total electrical input power; optical power was not subtracted from input power. The thermal interface material used during testing is not included in the thermal resistance value.
7.  $V_f$  min hot and max cold values are provided as reference only and are not guaranteed by test. These values are provided to aid in driver design and selection over the operating range of the product.

# Eye Safety

**Table 6:** Eye Safety Risk Group (RG) Classifications

Part Number	Drive Current <sup>2</sup> (mA)	CCT <sup>1,2</sup>	
		2700K/3000K	4000K
BXRE-xxx300x-D-7x	700	RG1	RG1
	1050	RG1	RG1
	1400	RG1	RG1

Notes for Table 6:

1. Eye safety classification for the use of Bridgelux V Series LED arrays is in accordance with specification IEC/TR 62778: Application of IEC 62471 for the assessment of blue light hazard to light sources and luminaires.
2. Please contact your Bridgelux sales representative for E<sub>thr</sub> values at specific drive currents and CCTs not listed.

# Absolute Maximum Ratings

**Table 7:** Maximum Ratings

Parameter	Maximum Rating
LED Junction Temperature ( $T_j$ )	125°C
Storage Temperature	-40°C to +105°C
Operating Case Temperature <sup>1</sup> ( $T_c$ )	105°C
Soldering Temperature <sup>2</sup>	300°C or lower for a maximum of 6 seconds
Maximum Drive Current <sup>3</sup>	1400mA
Maximum Peak Pulsed Drive Current <sup>4</sup>	2000mA
Maximum Reverse Voltage <sup>5</sup>	-60V

Notes for Table 7:

1. For IEC 62717 requirement, please consult your Bridgelux sales representative.
2. Refer to Bridgelux Application Note AN101: Assembly Considerations for Bridgelux V Series LED Arrays.
3. Arrays may be driven at higher currents however lumen maintenance may be reduced.
4. Bridgelux recommends a maximum duty cycle of 10% and pulse width of 20 ms when operating LED Arrays at maximum peak pulsed current specified. Maximum peak pulsed currents indicate values where LED Arrays can be driven without catastrophic failures.
5. Light emitting diodes are not designed to be driven in reverse voltage and will not produce light under this condition. Maximum rating provided for reference only.

# Performance Curves

**Figure 1: Drive Current vs. Voltage ( $T_j = T_c = 25^\circ\text{C}$ )**

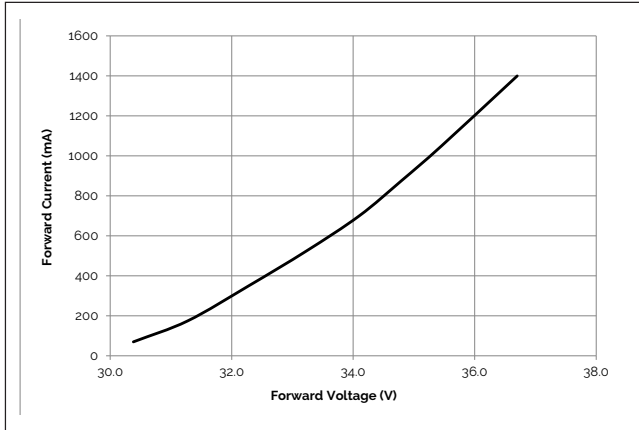

**Figure 2: Typical Relative Luminous Flux vs. Drive Current ( $T_j = T_c = 25^\circ\text{C}$ )<sup>1</sup>**

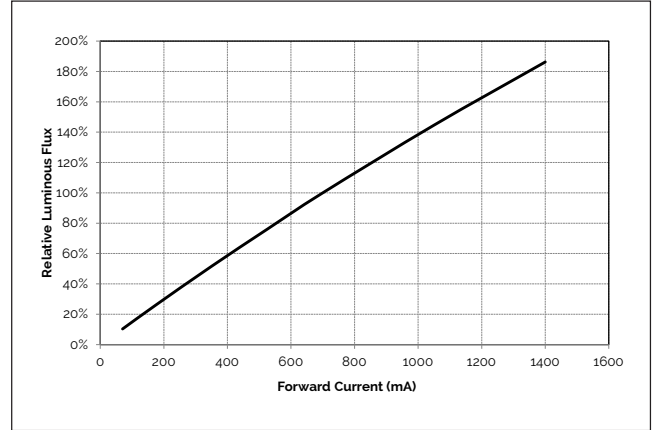

**Figure 3: Typical DC Flux vs. Case Temperature**

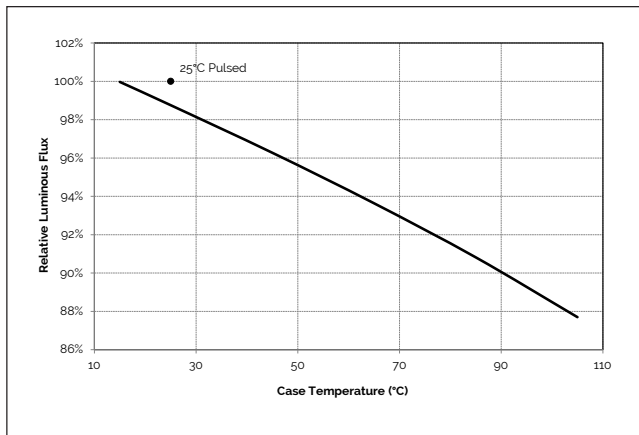

**Figure 4: Typical DC ccy Shift vs. Case Temperature<sup>2,3</sup>**

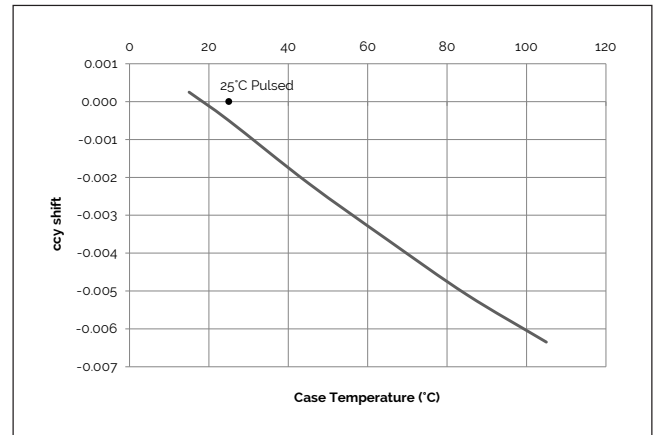

**Figure 5: Typical DC ccx Shift vs. Case Temperature<sup>2,3</sup>**

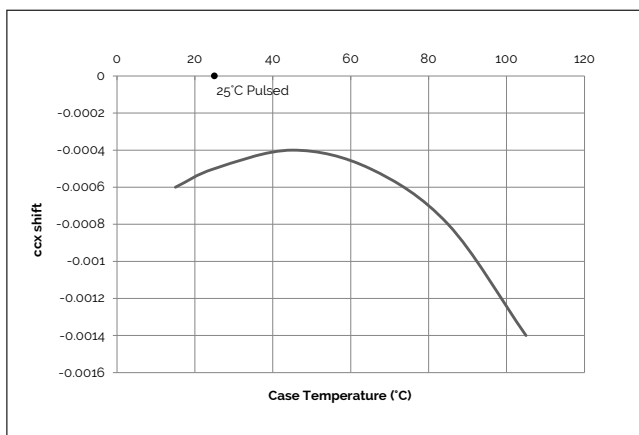

Notes for Figures 1-5:

1. Bridgelux does not recommend driving high power LEDs at low currents. Doing so may produce unpredictable results. Pulse width modulation (PWM) is recommended for dimming effects.
2. Characteristics shown for warm white based on 3000K and 90 CRI.
3. For other color SKUs, the shift in color will vary. Please contact your Bridgelux Sales Representative for more information.

# Typical Radiation Pattern

Figure 6: Typical Spatial Radiation Pattern

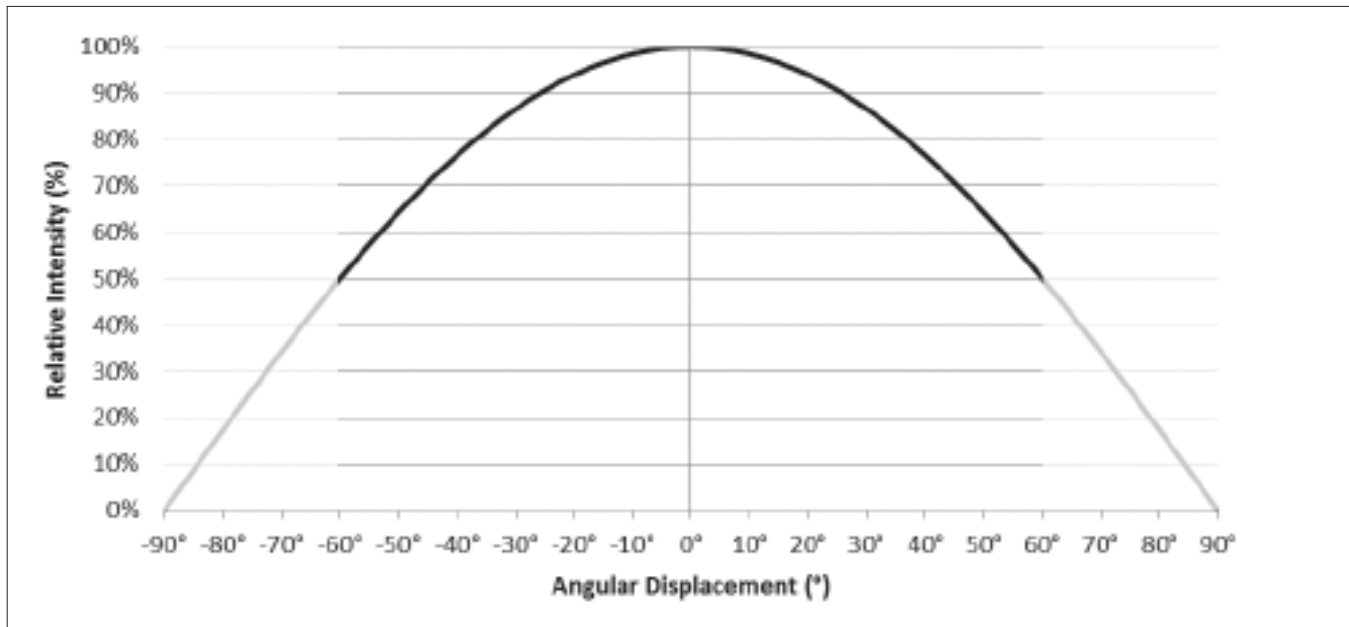

Notes for Figure 6:

1. Typical viewing angle is 120°.
2. The viewing angle is defined as the off axis angle from the centerline where  $I_v$  is  $\frac{1}{2}$  of the peak value.

Figure 7: Typical Polar Radiation Pattern

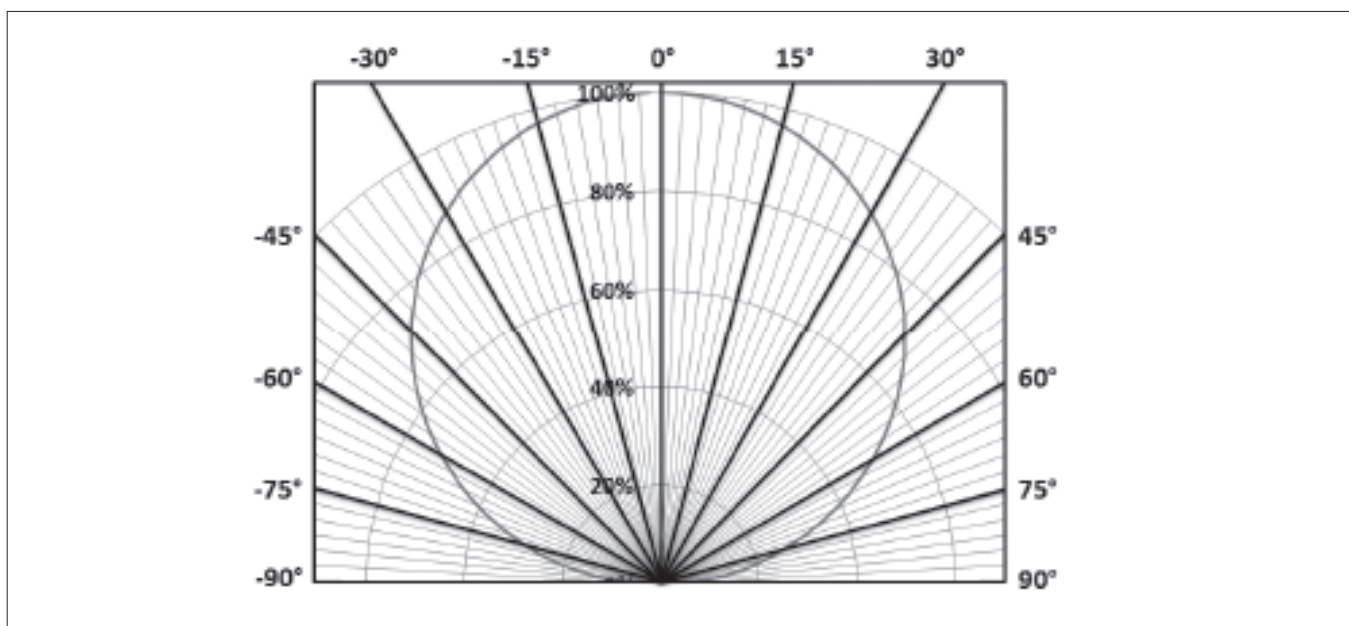

# Typical Color Spectrum

Figure 8: Typical Color Spectrum

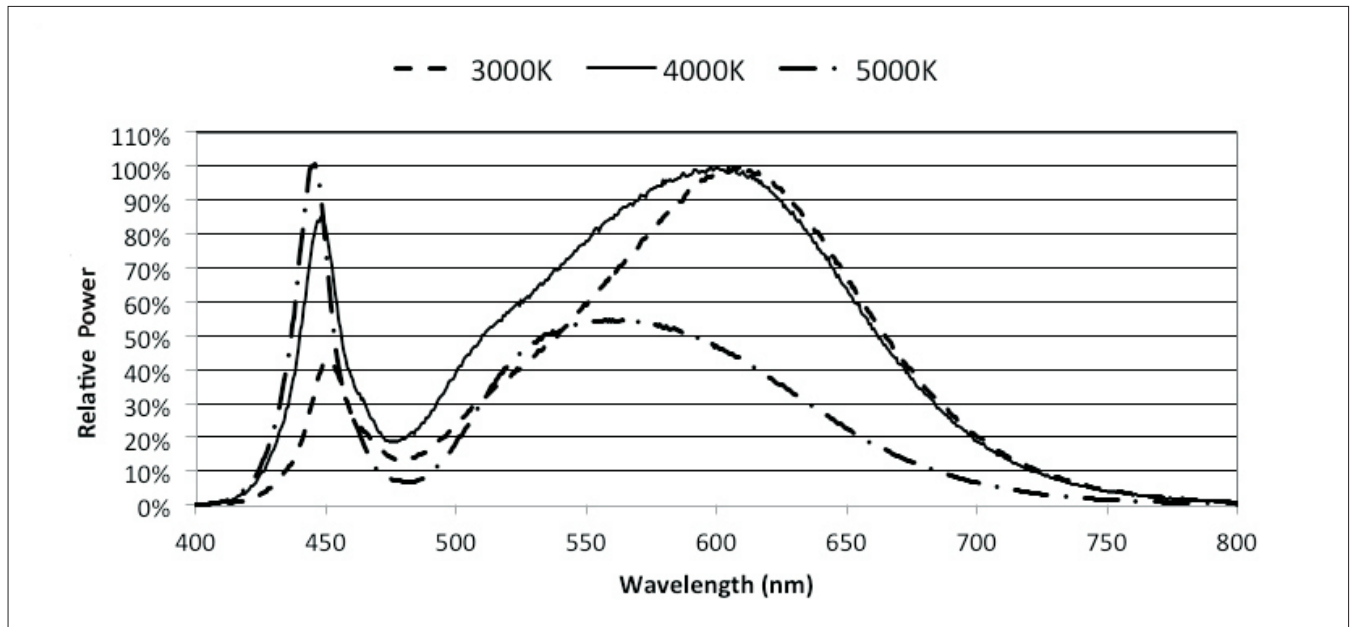

Notes for Figure 8:

1. Color spectra measured at nominal current for  $T_j - T_c = 25^\circ\text{C}$ .
2. Color spectra shown for warm white is 3000K and 80 CRI.
3. Color spectra shown for neutral white is 4000K and 80 CRI.
4. Color spectra shown for cool white is 5000K and 70 CRI.

# Mechanical Dimensions

Figure 9: Drawing for V15 LED Array

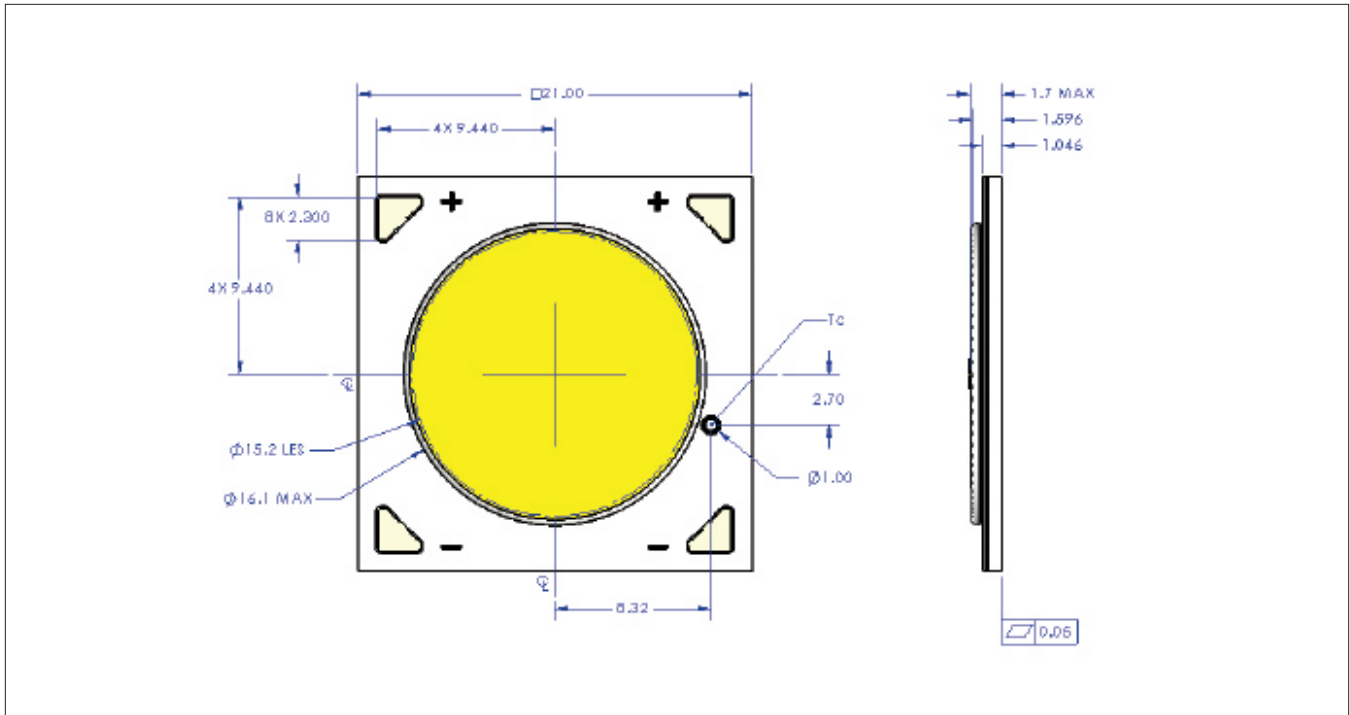

Notes for Figure 9:

1. Solder pads are labeled "+" and "-" to denote positive and negative polarity, respectively.
2. It is not necessary to provide electrical connections to both sets of solder pads. Either set may be used depending on application specific design requirements.
3. Drawings are not to scale.
4. Drawing dimensions are in millimeters.
5. Unless otherwise specified, tolerances are  $\pm 0.10\text{mm}$ .
6. The optical center of the LED Array is nominally defined by the mechanical center of the array. The light emitting surface (LES) is centered on the mechanical center of the array to a tolerance of  $\pm 0.2\text{ mm}$
7. Bridgelux maintains a flatness of 0.1 mm across the mounting surface of the array. Refer to Application Notes AN40 and AN41 for product handling, mounting and heat sink recommendations.

# Color Binning Information

**Figure 10: Graph of Warm and Neutral White Test Bins in xy Color Space**

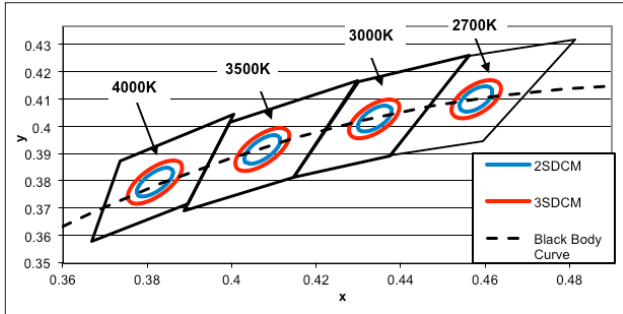

Note: Pulsed Test Conditions,  $T_c = 25^\circ\text{C}$

**Table 8: Warm and Neutral White xy Bin Coordinates and Associated Typical CCT**

Bin Code	2700K	3000K	3500K	4000K
ANSI Bin (for reference only)	(2580K - 2870K)	(2870K - 3220K)	(3220K - 3710K)	(3710K - 4260K)
72 (2 SDCM)	(2674K - 2769K)	(2995K - 3107K)	(3404K - 3548K)	(3895K - 4081K)
73 (3 SDCM)	(2651K - 2794K)	(2968K - 3136K)	(3369K - 3586K)	(3851K - 4130K)
Center Point (x,y)	(0.4578, 0.4101)	(0.4338, 0.403)	(0.4073, 0.3917)	(0.3818, 0.3797)

Notes for Table 8:

- Color Binning information excludes Class A, hot targeted and customer specific color points. Please contact your Bridgelux Sales Representative for more information
- Bridgelux maintains a tolerance of +/- 0.007 on x and y color coordinates in the CIE 1931 color Space.



# Packaging and Labeling

Figure 11: Drawing for V Series Packaging Tray

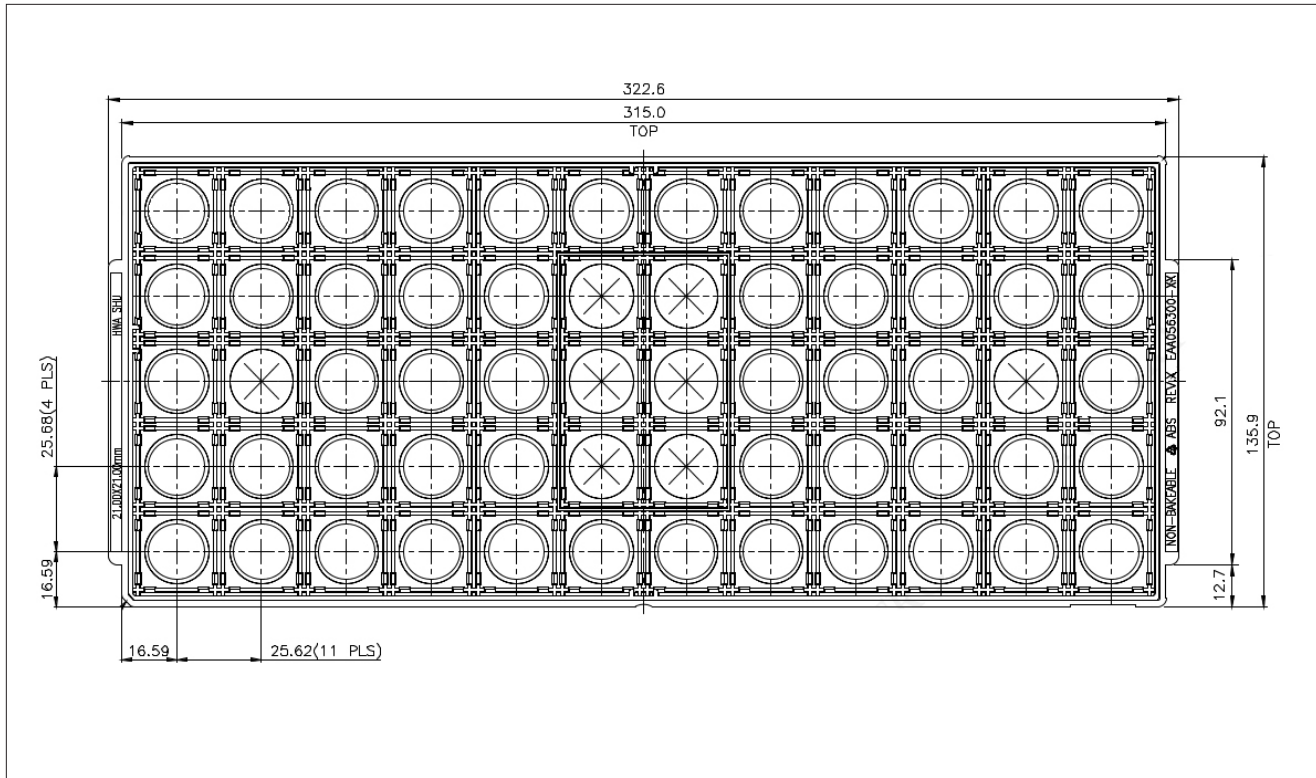

Notes for Figure 11:

1. Dimensions are in millimeters
2. Tolerances: XX -  $\pm 0.25$ , XXX -  $\pm 0.13$ , X'o' -  $\pm 0'30'$
3. Trays are stackable without interference and will not stick together during unstacking operation

# Packaging and Labeling

**Figure 12: V Series Packaging and Labeling**

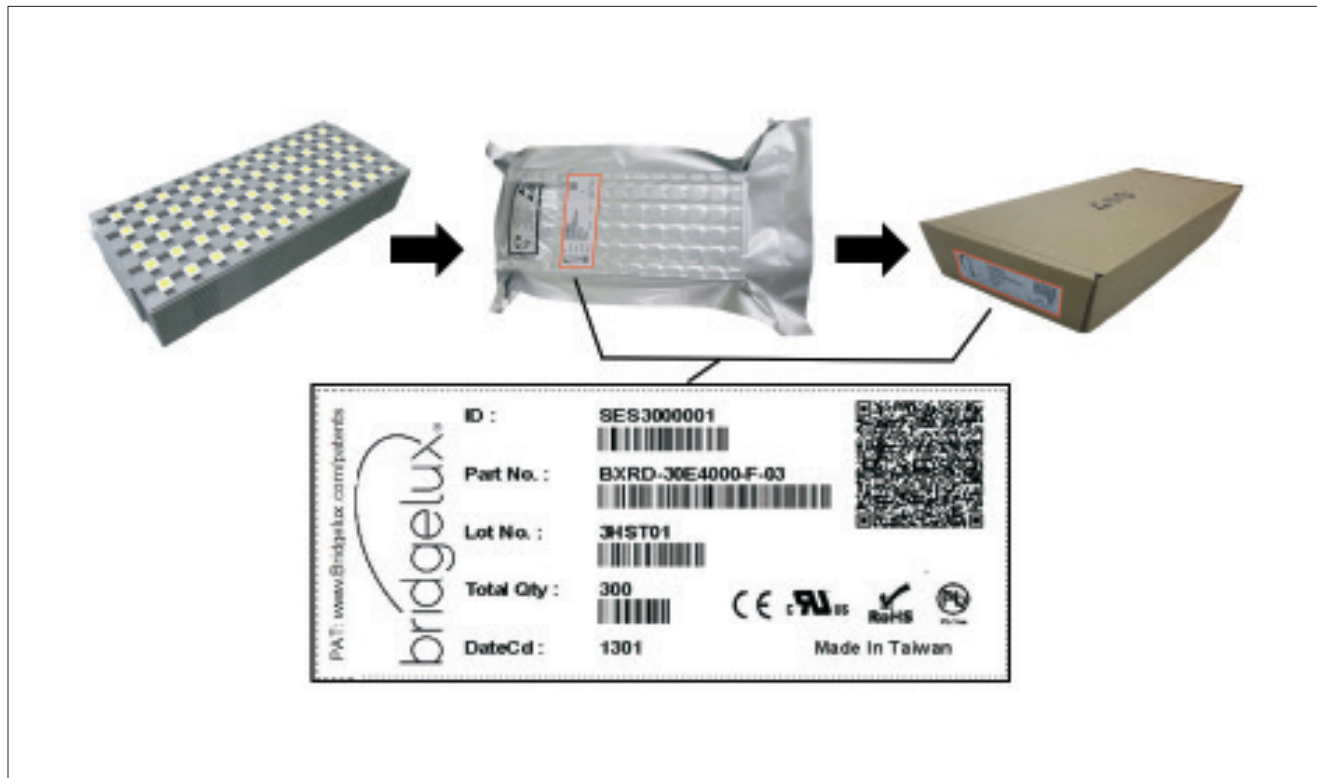

Notes for Figure 12:

1. Each tray holds 60 COB arrays, 10 trays are stacked and one empty tray placed on top to cover the top tray.
2. Stacked trays are to contain only 1 part number and be vacuum sealed in an anti-static bag and placed in its own individual box.
3. Each bag and box is to be labeled as shown above.

**Figure 13: Product Labeling**

Bridgelux COB arrays have laser markings on the back side of the substrate to help with product identification. In addition to the product identification markings, Bridgelux COB arrays also contain markings for internal Bridgelux manufacturing use only. The image below shows which markings are for customer use and which ones are for Bridgelux internal use only. The Bridgelux internal manufacturing markings are subject to change without notice, however these will not impact the form, function or performance of the COB array.



# Design Resources

## Application Notes

Bridgelux has developed a comprehensive set of application notes and design resources to assist customers in successfully designing with the V Series product family of LED array products. For a list of resources under development, visit [www.bridgelux.com](http://www.bridgelux.com).

## Optical Source Models

Optical source models and ray set files are available for all Bridgelux products. For a list of available formats, visit [www.bridgelux.com](http://www.bridgelux.com).

## 3D CAD Models

Three dimensional CAD models depicting the product outline of all Bridgelux V Series LED arrays are available in both IGS and STEP formats. Please contact your Bridgelux sales representative for assistance.

## LM80

LM80 testing has been completed and the LM80 report is now available. Please contact your Bridgelux sales representatives for LM-80 report.

# Precautions

## CAUTION: CHEMICAL EXPOSURE HAZARD

Exposure to some chemicals commonly used in luminaire manufacturing and assembly can cause damage to the LED array. Please consult Bridgelux Application Note AN101 for additional information.

## CAUTION: RISK OF BURN

Do not touch the V Series LED array during operation. Allow the array to cool for a sufficient period of time before handling. The V Series LED array may reach elevated temperatures such that could burn skin when touched.

## CAUTION

### CONTACT WITH LIGHT EMITTING SURFACE (LES)

Avoid any contact with the LES. Do not touch the LES of the LED array or apply stress to the LES (yellow phosphor resin area). Contact may cause damage to the LED array.

Optics and reflectors must not be mounted in contact with the LES (yellow phosphor resin area).

# Disclaimers

## MINOR PRODUCT CHANGE POLICY

The rigorous qualification testing on products offered by Bridgelux provides performance assurance. Slight cosmetic changes that do not affect form, fit, or function may occur as Bridgelux continues product optimization.

## STANDARD TEST CONDITIONS

Unless otherwise stated, array testing is performed at the nominal drive current.

# About Bridgelux: We Build Light That Transforms

At Bridgelux, we help companies, industries and people experience the power and possibility of light. Since 2002, we've designed LED solutions that are high performing, energy efficient, cost effective and easy to integrate. Our focus is on light's impact on human behavior, delivering products that create better environments, experiences and returns—both experiential and financial. And our patented technology drives new platforms for commercial and industrial luminaires.

**For more information about the company, please visit**

**[bridgelux.com](http://bridgelux.com)**

**[twitter.com/Bridgelux](https://twitter.com/Bridgelux)**

**[facebook.com/Bridgelux](https://facebook.com/Bridgelux)**

**[youtube.com/user/Bridgelux](https://youtube.com/user/Bridgelux)**

**[linkedin.com/company/bridgelux-inc-\\_2](https://linkedin.com/company/bridgelux-inc-_2)**

**WeChat ID: BridgeluxInChina**



46410 Fremont Boulevard

Fremont, CA 94538 USA

Tel (925) 583-8400

**[www.bridgelux.com](http://www.bridgelux.com)**

© 2021 Bridgelux, Inc. All rights reserved 2018. Product specifications are subject to change without notice. Bridgelux, the Bridgelux stylized logo design and V Series are registered trademarks, and Decor Series is a trademark of Bridgelux, Inc. All other trademarks are the property of their respective owners.

**Bridgelux V15D Array Series Product Data Sheet DS106 Rev. E (11/2022)**