

## 60V 17A N-Channel Enhancement Mode Power MOSFET

### FEATURES

- $R_{DS(on)} \leq 9m\Omega$  @  $V_{GS}=10V, I_D=15A$
- Excellent  $R_{DS(on)}$  and Low Gate Charge
- Lead free product is acquired

### APPLICATION

- Load Switch
- PWM Application
- Power management

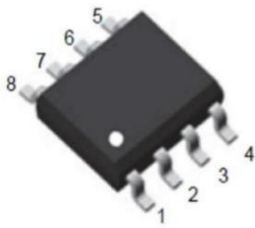

SOP-8 top view

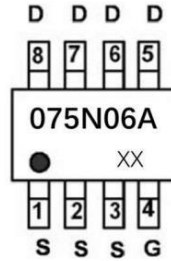

Marking and pin Assignment

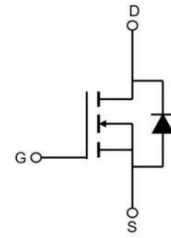

Schematic Diagram

### ASSEMBLY MESSAGE

Product Name	Marking	Package	Packaging
BXT090N06B	075N06A	SOP-8	Reel

### ABSOLUTE MAXIMUM RATINGS ( $T_C=25^\circ C$ unless otherwise noted)

Parameter	Symbol	Rating	Unit	
		SOP-8		
Drain-Source Voltage	$V_{DSS}$	60	V	
Drain Current	Continuous ( $T_C = 25^\circ C$ )	17	A	
	Continuous ( $T_C = 100^\circ C$ )	11	A	
Drain Current	Pulsed (Note1)	68	A	
Gate-Source Voltage	$V_{GSS}$	$\pm 20$	V	
Single Pulsed Avalanche Energy (note2)	EAS	140	mJ	
Power Dissipation	$T_C = 25^\circ C$	$P_D$	4.8	W
Maximum Junction Temperature	$T_J$	150	$^\circ C$	
Storage Temperature Range	$T_{STG}$	-55 to 150	$^\circ C$	

- Note:**
1. Repetitive Rating: Pulse width limited by maximum junction temperature
  2. EAS condition :  $T_J=25^\circ C, V_{DD}=30V, V_G=10V, L=0.5mH, R_g=25\Omega, I_{AS}=23.7A$

**THERMAL CHARACTERISTICS**

Parameter	Symbol	Max.	Unit
		SOP-8	
Thermal Resistance, Junction to Ambient	$R_{\theta JA}$	26	$^{\circ}\text{C} / \text{W}$

**ELECTRICAL CHARACTERISTICS** ( $T_J=25^{\circ}\text{C}$ , unless otherwise Noted)

Parameter	Symbol	Test Condition	Min.	Typ.	Max.	Unit
<b>OFF CHARACTERISTICS</b>						
Drain-Source Breakdown Voltage	$BV_{DSS}$	$V_{GS}=0V, I_D=250\mu A$	60			V
Zero Gate Voltage Drain Current	$I_{DSS}$	$V_{DS}=60V, V_{GS}=0V$			1	$\mu A$
Gate-Body Leakage Current, Forward	$I_{GSS}$	$V_{GS}=20V$			100	nA
Gate-Body Leakage Current, Reverse		$V_{GS}=-20V$			-100	nA
<b>ON CHARACTERISTICS</b>						
Gate Threshold Voltage	$V_{GS(TH)}$	$V_{DS}=V_{GS}, I_D=250\mu A$	1.0	1.7	2.5	V
Drain-Source On-State Resistance	$R_{DS(ON)}$	$V_{GS}=10V, I_D=15A$		6.7	9	$m\Omega$
		$V_{GS}=4.5V, I_D=10A$		8.5	12	$m\Omega$
<b>DYNAMIC PARAMETERS</b>						
Input Capacitance	$C_{ISS}$	$V_{DS}=25V, V_{GS}=0V,$ $f=1.0MHz$		1100		pF
Output Capacitance	$C_{OSS}$			302		pF
Reverse Transfer Capacitance	$C_{RSS}$			27		pF
<b>SWITCHING PARAMETERS</b>						
Turn-ON Delay Time	$t_{D(ON)}$	$V_{DD}=30V, I_D=15A, V_{GS} =$ $10V, R_G=1.8\Omega$		9.2		ns
Turn-ON Rise Time	$t_R$			6.2		ns
Turn-OFF Delay Time	$t_{D(OFF)}$			33.1		ns
Turn-OFF Fall-Time	$t_F$			7.6		ns
Total Gate Charge(Note3)	$Q_G$	$V_{DS} =30V, V_{GS} =10V, I_D$ $=10A$		99		nC
Gate Source Charge	$Q_{GS}$			12.6		nC
Gate Drain Charge	$Q_{GD}$			32.1		nC
<b>SOURCE- DRAIN DIODE RATINGS AND CHARACTERISTICS</b>						
Drain-Source Diode Forward Voltage	$V_{SD}$	$I_S=15A, V_{GS}=0V$			1.2	V
Diode Continuous Forward Current	$I_S$				17	A
Maximum Pulsed Drain to Source Diode Forward Current	$I_{SM}$				68	A
Body Diode Reverse Recovery Time	$t_{rr}$	$I_F=15A, di/dt=100A/\mu s$		30		ns
Body Diode Reverse Recovery Charge	$Q_{rr}$				49	

Note: 3. Essentially independent of operating temperature

**TYPICAL CHARACTERISTICS**

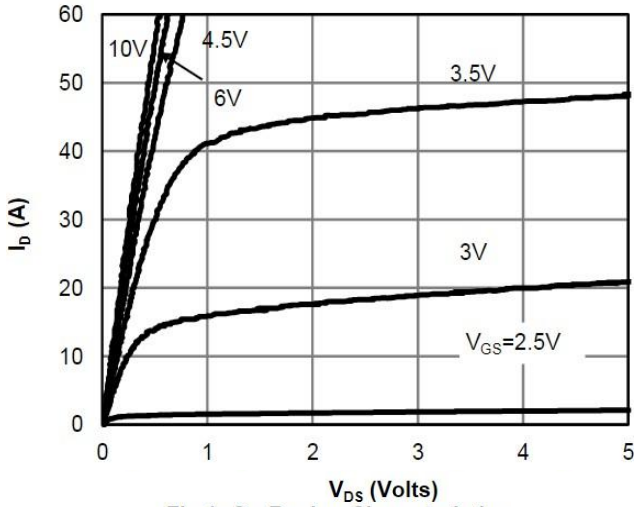

Fig 1: On-Region Characteristics

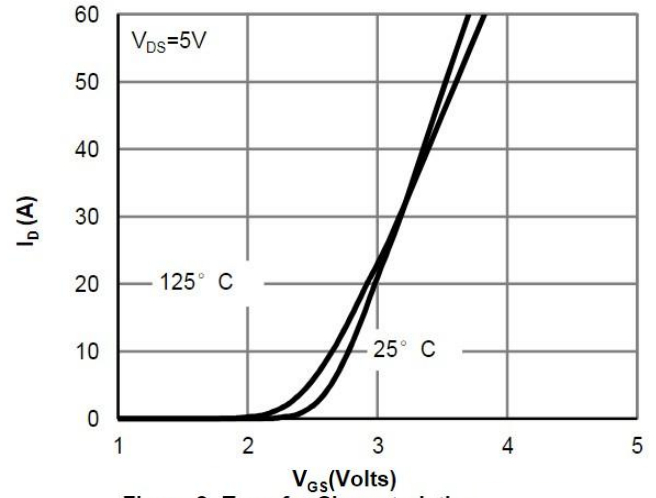

Figure 2: Transfer Characteristics

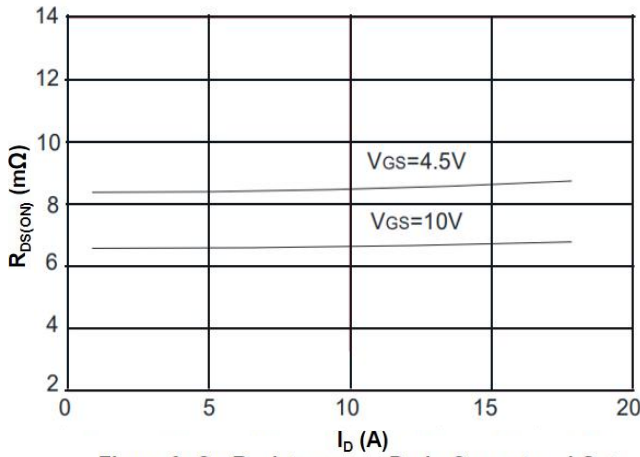

Figure 3: On-Resistance vs. Drain Current and Gate Voltage

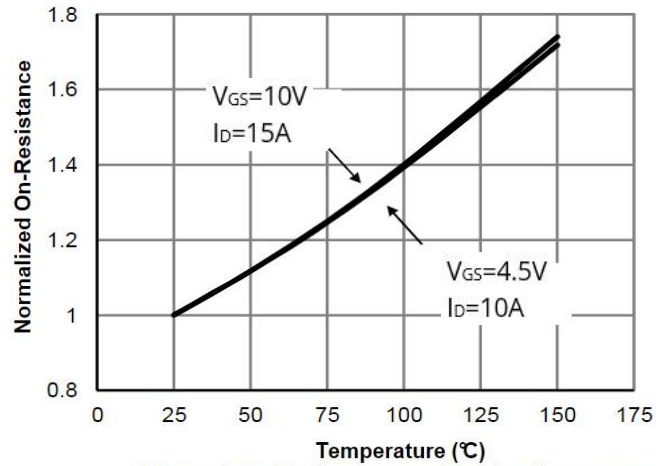

Figure 4: On-Resistance vs. Junction Temperature

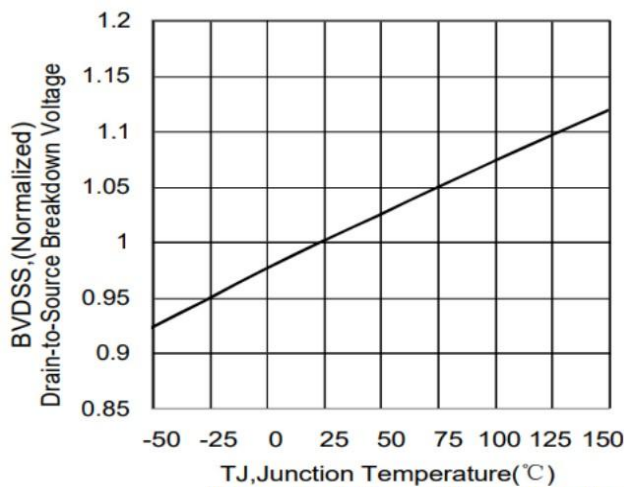

Figure 5: Bvdss Variation with Temperature

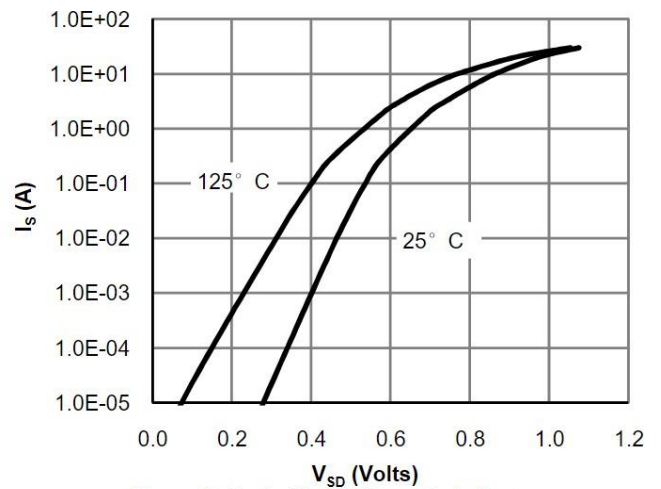

Figure 6: Body-Diode Characteristics

**TYPICAL CHARACTERISTICS(Cont.)**

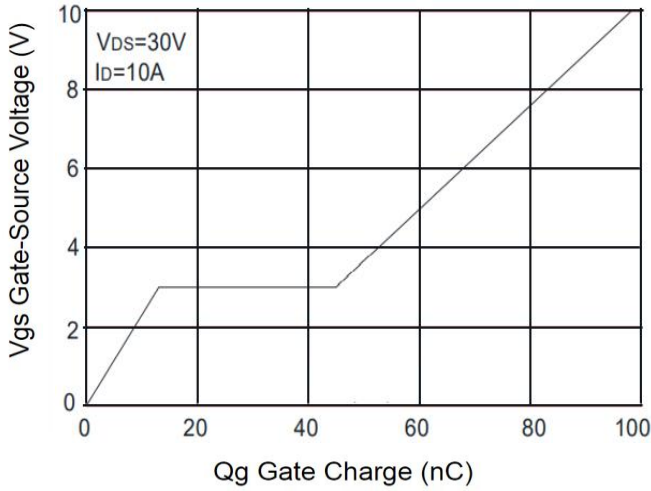

Figure 7: Gate-Charge Characteristics

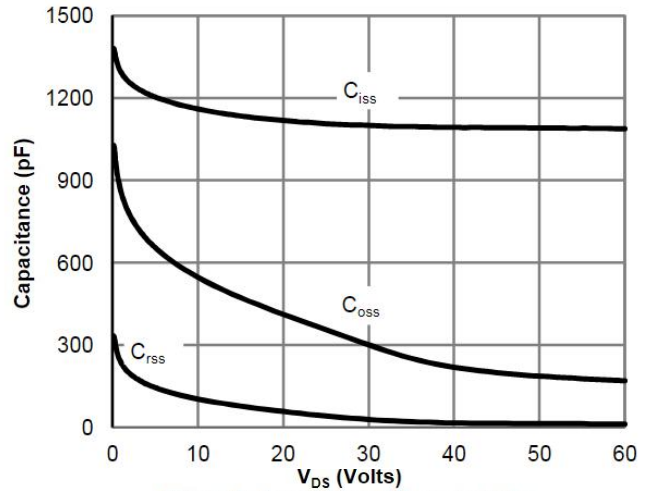

Figure 8: Capacitance Characteristics

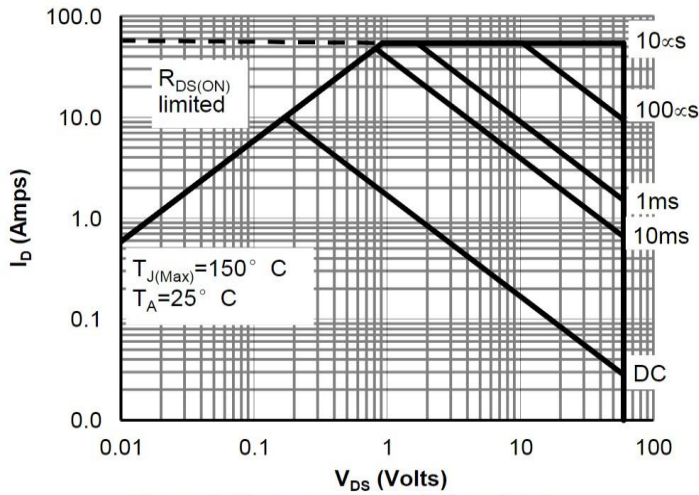
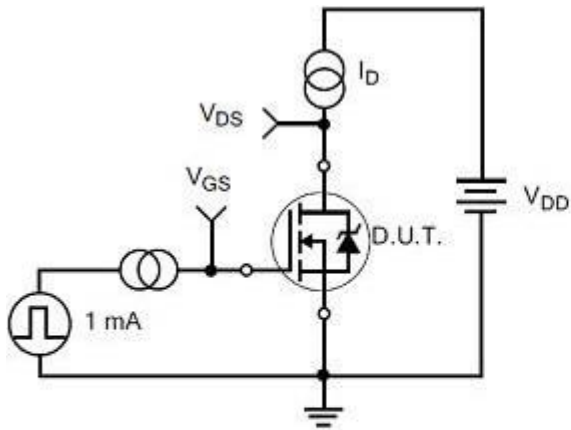
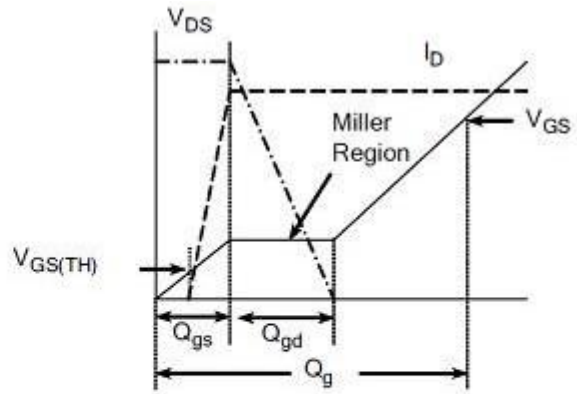

Figure 9: Maximum Forward Biased Safe Operating Area

TEST CIRCUITS AND WAVEFORMS



Gate Charge Test Circuit



Gate Charge Waveform

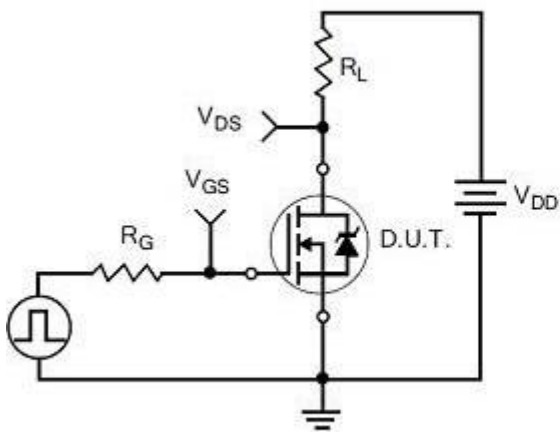

Resistive Switching Test Circuit

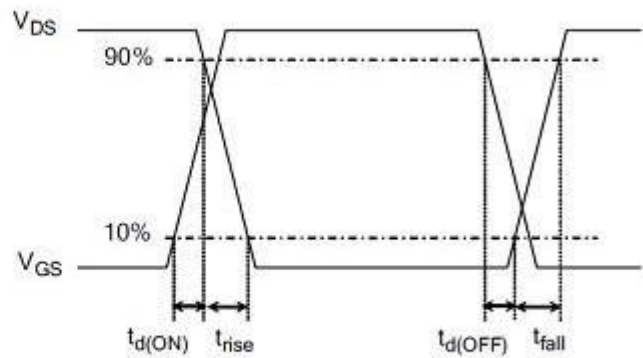

Resistive Switching Waveforms

TEST CIRCUITS AND WAVEFORMS(Cont.)

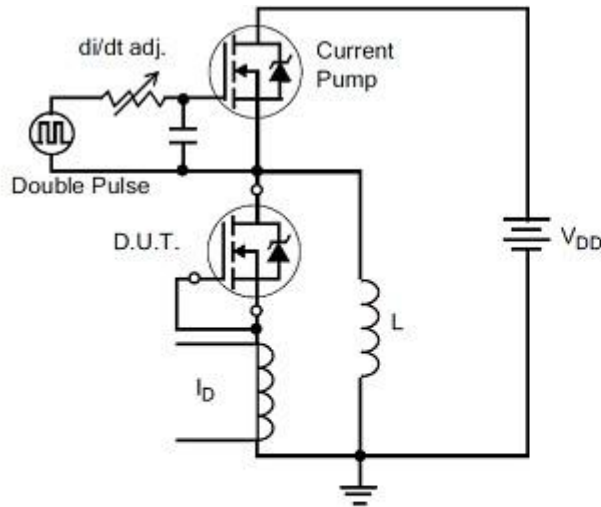

Diode Reverse Recovery Test Circuit

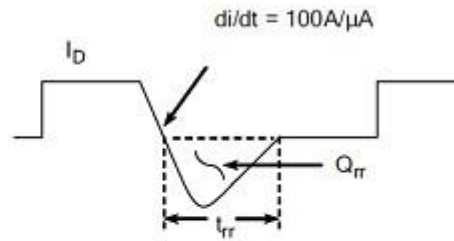

Diode Reverse Recovery Waveform

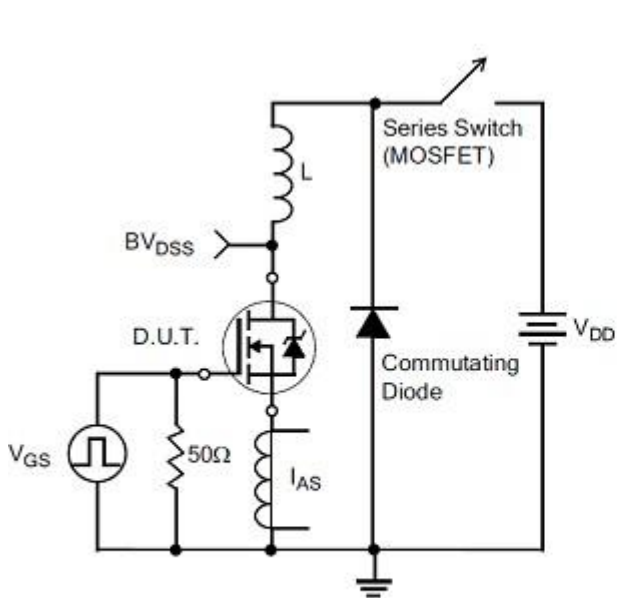

Unclamped Inductive Switching Test Circuit

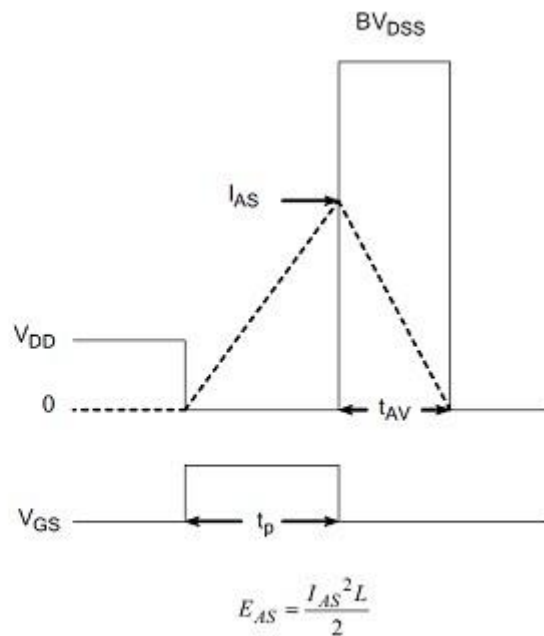

Unclamped Inductive Switching Waveforms

### SOP-8 Package

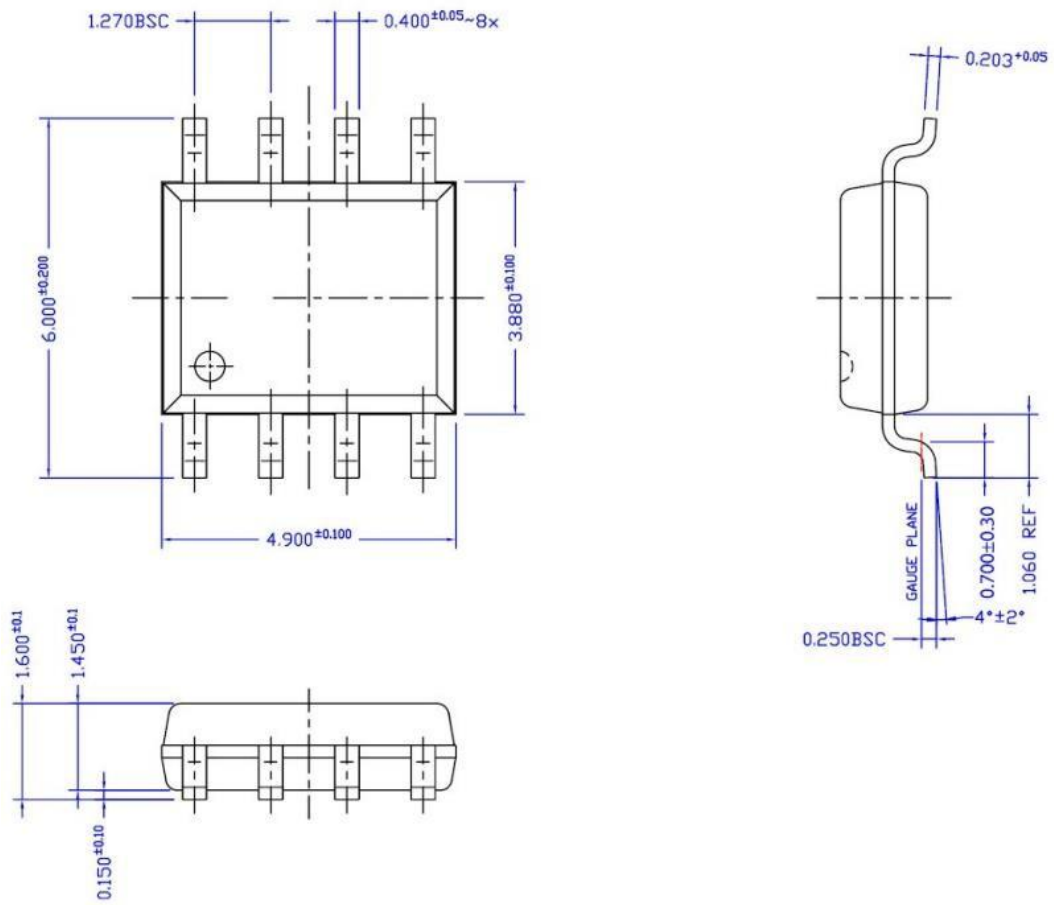

## Revision history

### Document revision history

Date	Revision	Changes
20-Mar-2021	1.0	First release



**Disclaimers:**

Bridgelux WuXi has made reasonable commercial efforts to ensure that the information given in this data sheet is correct. However, it must clearly be understood that such information is for guidance only and does not constitute any representation or form part of any offer or contract.

For documents and material available from this data sheet, Bridgelux WuXi does not warrant or assume any legal liability or responsibility for the accuracy, completeness, or usefulness of any information, product, technology or process disclosed hereunder.

Bridgelux WuXi reserves the rights to at its own discretion to make any changes or improvements to this data sheet. Unless said data sheet is incorporated into the formal contract, any customer should not rely on the information as any specification or product parameters duly committed by Bridgelux WuXi. Customers are hereby advised to verify that the information contained herein is current and complete before the entering of any contract or acknowledgement of any purchase order. Accordingly, all products specified hereunder shall be sold subject to Bridgelux WuXi's terms and conditions supplied at the time of order acknowledgement. Except where agreed upon by contractual agreement, testing of all parameters of each product is not necessarily performed.

Bridgelux WuXi does not warrant or convey any license either expressed or implied under its patent rights, nor the rights of others. Reproduction of information contained herein shall be only permissible if such reproduction is without any modification or alteration. Reproduction of this information with any alteration is an unfair and deceptive business practice. Bridgelux WuXi is not responsible or liable for such altered documentation.

Resale of Bridgelux WuXi's products with statements different from or beyond the parameters stated by Bridgelux WuXi for that product or service voids all express or implied warranties for the associated Bridgelux WuXi's product or service and is unfair and deceptive business practice. Bridgelux WuXi is not responsible or liable for any such statements.

Bridgelux WuXi's products are not authorized for use as critical components in life support devices or systems without the express written approval of Bridgelux WuXi. As used herein:

1. Life support devices or systems are devices or systems which, (a) are intended for surgical implant into the body, or (b) support or sustain life, and whose failure to perform, when properly used in accordance with instructions for use provided in the labeling, can be reasonably expected to result in a significant injury to the user.
2. A critical component is any component of a life support device or system whose failure to perform can be reasonably expected to cause the failure of the life support device or system, or to affect its safety or effectiveness.