

Bridgelux® CSP 1313 RGBW Gen2 Series

Product Data Sheet DS965

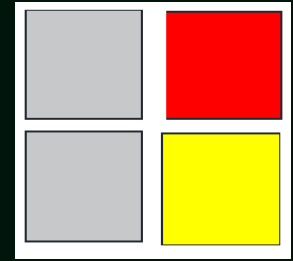

Introduction

CSP 1313 RGBW Gen2 offer exceptional performance in an ultra compact size. CSP 1313 RGBW Gen2 is advanced palette of Color and White LEDs options, which is designed for color mixing and high CRI tunable white on blackbody Locus. With its superior performance without bonding wires and ability to assemble a densely populated and high luminous flux LED board, CSP 1313 RGBW Gen2 provides unparalleled design-in flexibility for indoor and outdoor lighting applications. CSP 1313 RGBW Gen2 is ideal as a drop in replacement for emitters with an industry standard 1.3mm x 1.3mm footprint.

Features

- Industry-standard 1313 footprint
- RoHS compliant and lead free
- RGBW Gen2 is for entertainment lighting application.
- RGBW Gen2 is for tunable white along BBL from 2700K-6500K with high CRI95.

Benefits

- Lower operating and manufacturing cost
- Ease of design and rapid go-to-market
- Compliant with environmental standards
- Design flexibility

Contents

Product Feature Map	2
Product Selection Guide	5
Performance at Commonly Used Drive Currents	6
Absolute Maximum Ratings	7
Product Bin Definitions	8
Performance Curves	10
Typical Color Spectrum	13
Mechanical Dimensions	14
Reflowing Characteristics	16
Packaging	17
Design Resources	19
Precautions	19
Disclaimers	19
About Bridgelux	20

Product Feature Map

Bridgelux CSP LED products offer exceptional performance and color quality all in a highly reliable, cost effective, compact package. Our CSP products come in industry standard package sizes and follow ANSI binning standards.

These LEDs are optimized for cost and performance, helping to ensure highly competitive system lumen per dollar performance while addressing the stringent efficacy and reliability standards required for modern lighting applications.

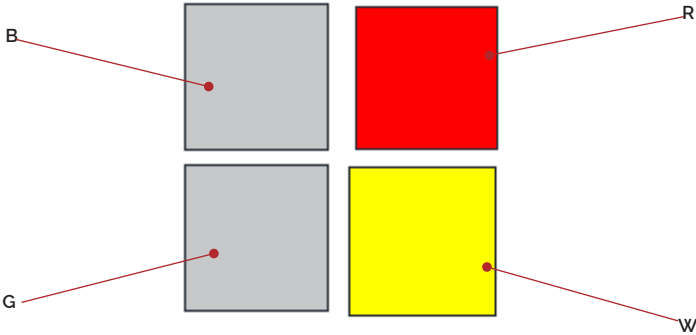

Light Emitting Surface (LES)

Product Nomenclature

The part number designation for Bridgelux CSP 1313 RGBW Gen2 is explained as follows:

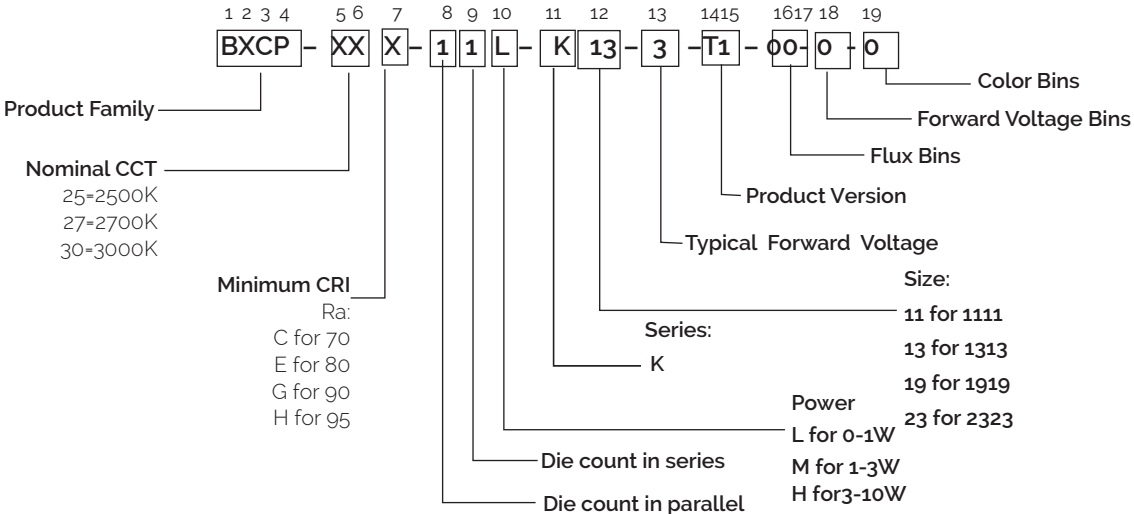

Product Feature Map

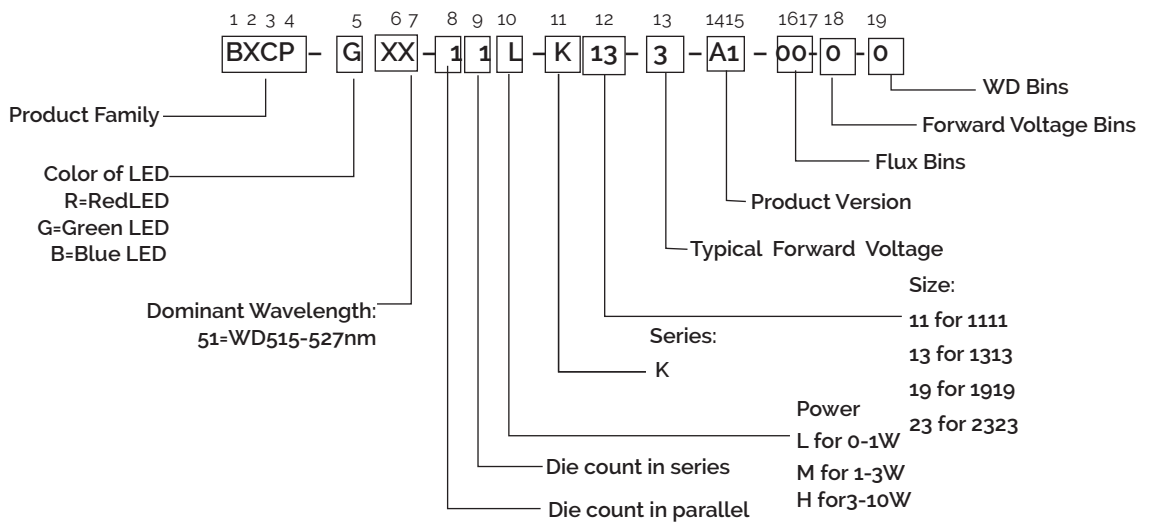
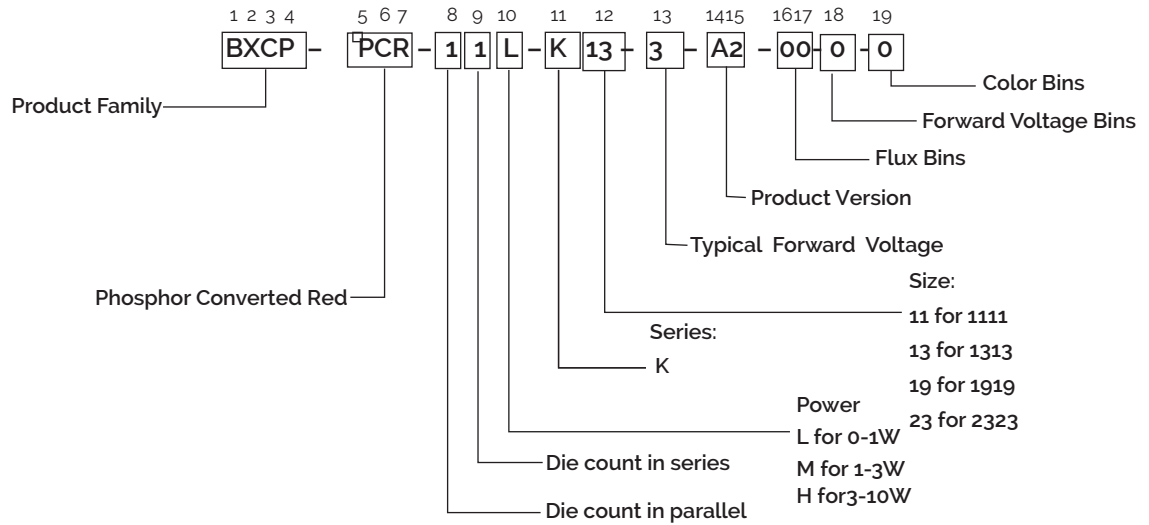

Product Feature Map

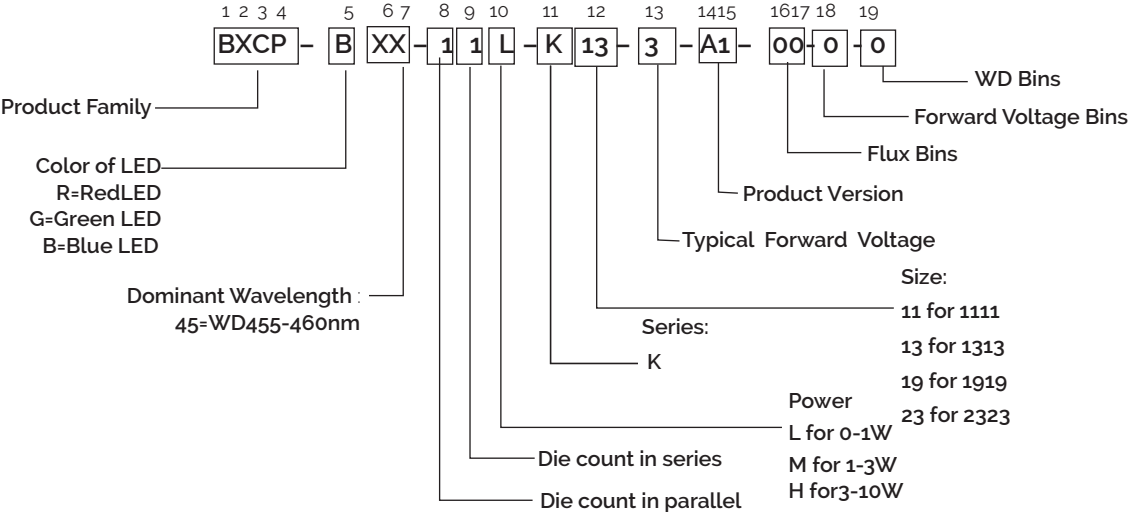

Product Test Conditions

Bridgelux CSP 1313 RGBW Gen2 LEDs are tested and binned with a 10ms pulse of 350mA at T_j (junction temperature)= T_{sp} (solder point temperature) =25°C. Luminous flux, color and forward voltage are binned at $T_j=T_{sp}=25°C$.

Product Selection Guide

The following product configurations are available:

Table 1: Selection Guide, RGB pulsed Measurement Data at 350mA ($T_j=T_{sp}=25^{\circ}\text{C}$)

Part Number	Dominant Wavelength(nm)			Purity	Nominal Drive Current (mA)	Forward Voltage (V)			Typical Pulsed Flux(lm)	Typical Power (W)	Typical Efficacy (lm/W)
	Min	Typical	Max			Min	Typical	Max			
BXCP-PCR-11L-K13-3-A2-00-0-0	609	615	625	0.941	250	2.70	2.80	3.10	34.0	0.7	49
BXCP-G51-11L-K13-3-A1-00-0-0	515	520	527.5	0.789	350	2.70	2.90	3.20	150.0	1.0	148
BXCP-B45-11L-K13-3-A1-00-0-0	455	/	460	0.989	350	2.80	3.00	3.20	25.0	1.1	24

Table 2: Selection Guide, W pulsed Measurement Data at 350mA ($T_j=T_{sp}=25^{\circ}\text{C}$)

Part Number	Nominal CCT(K)	CRI	Nominal Drive Current (mA)	Forward Voltage (V)			Typical Pulsed Flux(lm)	Typical Power (W)	Typical Efficacy (lm/W)
				Min	Typical	Max			
BXCP-30C-11L-K13-3-T1-00-0-0	3000	70	350	2.80	3.00	3.20	157	11	150

Notes for Tables 1 & 2 :

1. Products tested under pulsed condition (10ms pulse width) at nominal drive current where $T_j=T_{sp}=25^{\circ}\text{C}$.
2. Bridgelux maintains a $\pm 7.5\%$ tolerance on luminous flux measurements, $\pm 0.1\text{V}$ tolerance on forward voltage measurements for the CSP LED.
3. Typical pulsed test performance values are provided as reference only and are not a guarantee of performance.

Table 3: Selection Guide, RGB pulsed Measurement Data at 350mA ($T_j=T_{sp}=85^{\circ}\text{C}$)

Part Number	Dominant Wavelength(nm)			Purity	Nominal Drive Current (mA)	Forward Voltage (V)			Typical Pulsed Flux(lm)	Typical Power (W)	Typical Efficacy (lm/W)
	Min	Typical	Max			Min	Typical	Max			
BXCP-PCR-11L-K13-3-A2-00-0-0	610	615	625	0.929	350	2.60	2.80	3.10	30.0	1.0	31
BXCP-G51-11L-K13-3-A1-00-0-0	517	522	530	0.771	350	2.60	2.80	3.00	138.0	1.0	141
BXCP-B45-11L-K13-3-A1-00-0-0	455	\	462.5	0.987	350	2.70	2.90	3.20	25.3	1.0	25

Table 4: Selection Guide, W pulsed Measurement Data at 350mA ($T_j=T_{sp}=85^{\circ}\text{C}$)

Part Number	Nominal CCT(K)	CRI	Nominal Drive Current (mA)	Forward Voltage (V)			Typical Pulsed Flux(lm)	Typical Power (W)	Typical Efficacy (lm/W)
				Min	Typical	Max			
BXCP-30C-11L-K13-3-T1-00-0-0	3000	70	350	2.70	2.90	3.20	143	10	141

Notes for Tables 3 & 4 :

1. Products tested under pulsed condition (10ms pulse width) at nominal drive current where $T_j=T_{sp}=85^{\circ}\text{C}$.
2. Bridgelux maintains a $\pm 7.5\%$ tolerance on luminous flux measurements, $\pm 0.1\text{V}$ tolerance on forward voltage measurements for the CSP LED.
3. Typical pulsed test performance values are provided as reference only and are not a guarantee of performance.

Performance at Commonly Used Drive Currents

RGBW Gen2 are tested to the specifications shown using the nominal drive current in Table 1 & 2. RGBW Gen2 may also be driven at other drive currents dependent on specific application design requirements. The performance at any drive current can be derived from the current vs. voltage characteristics shown in Figure 2 and the flux vs. current characteristics shown in Figure 3. The performance at commonly used drive currents is summarized in Table 5.

Table 5: Performance at Commonly Used Drive Currents

Part Number	CRI	Drive Current ¹ (mA)	Typical V_f $T_{sp} = 25^\circ\text{C}$ (V)	Typical Power $T_{sp} = 25^\circ\text{C}$ (W)	Typical Pulsed Flux ² $T_{sp} = 25^\circ\text{C}$ (lm)	Typical Pulsed Flux ³ $T_{sp} = 85^\circ\text{C}$ (lm)	Typical Efficacy $T_{sp} = 25^\circ\text{C}$ (lm/W)
BXCP-PCR-11L-K13-3-A2-00-0-0	\	50	2.5	0.1	8	7	63
		150	2.7	0.4	22	20	55
		200	2.7	0.5	28	25	51
		250	2.8	0.7	34	30	49
		300	2.9	0.9	39	35	45
BXCP-G51-11L-K13-3-A1-00-0-0	\	50	2.4	0.1	33	30	272
		150	2.6	0.4	81	74	206
		200	2.7	0.5	101	92	185
		300	2.9	0.9	135	124	156
		350	2.9	1.0	150	138	148
		450	3.1	1.4	179	164	127
		500	3.2	1.6	192	177	121
BXCP-B45-11L-K13-3-A1-00-0-0	\	50	2.6	0.1	4.2	4.8	32
		150	2.8	0.4	11.3	12.8	27
		200	2.8	0.6	14.3	16.2	25
		300	2.9	0.9	19.9	22.5	23
		350	3.0	1.0	25.0	25.3	24
		450	3.1	1.4	27.3	30.6	20
		500	3.1	1.6	29.6	33.1	19
BXCP-30C-11L-K13-3-T1-00-0-0	70	50	2.7	0.1	26	25	196
		150	2.8	0.4	74	69	177
		250	2.9	0.7	117	108	163
		350	3.0	1.1	157	143	150
		450	3.0	1.4	193	203	140
		500	3.1	1.5	211	243	137

Notes for Table 5:

1. Bridgelux maintains a $\pm 7.5\%$ tolerance on luminous flux measurements, $\pm 0.1\text{V}$ tolerance on forward voltage measurements for the CSP LED.
2. Typical pulsed test performance values are provided as reference only and are not a guarantee of performance.

Absolute Maximum Ratings

Table 6: Maximum Ratings

Parameter	Maximum Rating			
LED Junction Temperature (T_j)	135°C			
Storage Temperature	-40°C to +125°C			
Operating Solder Point Temperature (T_{sp}) ¹ For Red Color	85°C			
Operating Solder Point Temperature (T_{sp}) ¹ For Green/Blue/White Color	105°C			
Soldering Temperature	260°C or lower for a maximum of 10 seconds			
Color	R	G	B	W
Maximum Drive Current	300mA	500mA	500mA	500mA
Maximum Peak Pulsed Forward Current ²	500mA	700mA	700mA	700mA
Maximum Reverse Voltage ³	-5V			
Moisture Sensitivity Rating	MSL 3			

Notes for Table 6:

1. The maximum drive current is limited depending on the solder point temperature. Refer to Figure 5 and 6.
2. Bridgelux recommends a maximum duty cycle of 10% and pulse width of 10 ms when operating CSP LED at maximum peak pulsed current specified. Maximum peak pulsed current indicate values where CSP LED can be driven without catastrophic failures.
3. Light emitting diodes are not designed to be driven in reverse voltage and will not produce light under this condition. Maximum rating provided for reference only.

Product Bin Definitions

Table 7: Luminous Flux Bin Definitions at 350mA, $T_{sp}=25^{\circ}\text{C}$

Part Number	Bin Code	Minimum	Maximum	Unit	Condition
BXCP-PCR-11L-K13-3-A2-00-0-0	A1	30	40	lm	IF=350mA
	B1	40	50		
BXCP-G51-11L-K13-3-A1-00-0-0	K1	130	140		
	M1	140	150		
	N1	150	160		
	P1	160	170		
BXCP-B45-11L-K13-3-A1-00-0-0	Z0	10	20		
	A0	20	30		
BXCP-30C-11L-K13-3-T1-00-0-0	M1	140	150		
	N1	150	160		
	P1	160	170		

Note for Table 7:

1. Bridgelux maintains a tolerance of $\pm 7.5\%$ on luminous flux measurements.

Table 8: Forward Voltage Bin Definitions at 350mA, $T_{sp}=25^{\circ}\text{C}$

Bin Code	Minimum	Maximum	Unit	Condition
C	2.6	2.8	V	IF=350mA
D	2.8	3.0		
E	3.0	3.2		
F	3.2	3.4		

Note for Table 8:

1. Bridgelux maintains a tolerance of $\pm 0.1\text{V}$ on forward voltage measurements.

Table 9: Green and Blue Color Dominant Wavelength Bin Definitions at 350mA, $T_{sp}=25^{\circ}\text{C}$

Bin Code	Minimum	Maximum	Unit	Condition
G	455	457.5	nm	IF=350mA
H	457.5	460		
P	515	517.5		
R	517.5	520		
S	520	522.5		
T	522.5	525		
U	525	527.5		

Green Color Dominant Wavelength Kitting Equivalent to 520-522.5nm

WD Bin	Kitting Ratio 1:1	
Kitting 1	P	U
Kitting 2	R	T
S Bin does not need kitting		

Product Bin Definitions

Table 10: McAdam ellipse CCT color bin definitions for Product of RW at $T_c = 25^\circ\text{C}$

Channel	Color Space	Center Point		Major Axis	minor Axis	θ' (angle)	Color Bin
		x	y				
R	1	0.6692	0.3158	0.01854	0.00828	160.00	1
W	3	0.4634	0.4730	0.00834	0.00408	53.22	3
	5			0.01390	0.00680		5(E/F/G/H)

Table 11: GB Color Bin Definitions

Blue Rank					
X	0.1566	0.1355	0.1494	0.1706	0.15660
Y	0.0177	0.0399	0.0648	0.0415	0.01770
Green Rank					
X	0.1050	0.1050	0.2000	0.2000	0.1050
Y	0.7000	0.7500	0.7500	0.7000	0.7000

Notes for Tables 10 & 11:

1. Color binning at $T_{sp} = 25^\circ\text{C}$ unless otherwise specified
2. Bridgelux maintains a tolerance of ± 0.007 on x and y color coordinates.

Figure 1: C.I.E. 1931 Chromaticity Diagram

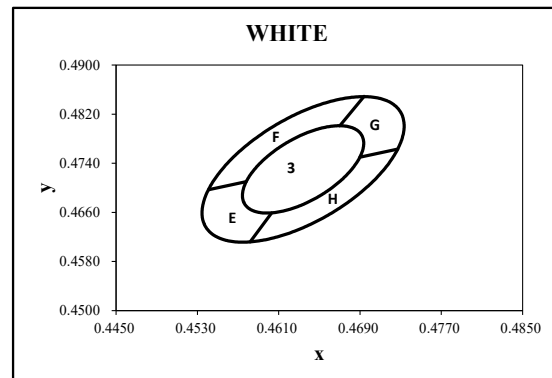
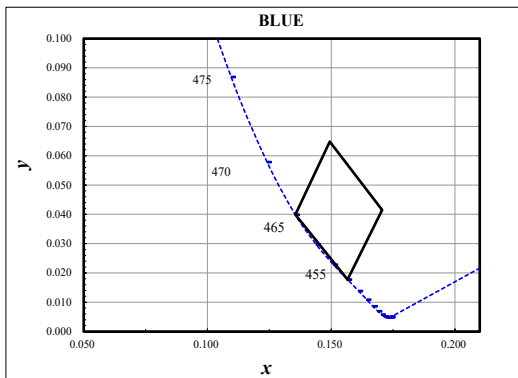
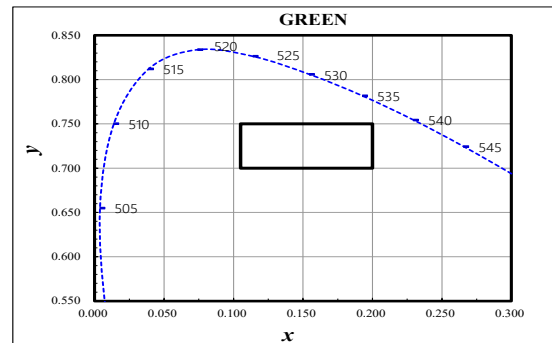
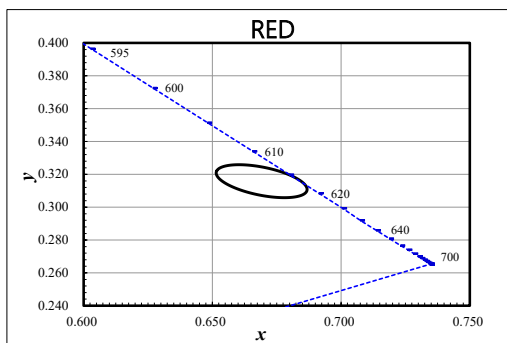

Performance Curves

Figure 2: Drive Current vs. Voltage ($T_{sp}=25^{\circ}\text{C}$)

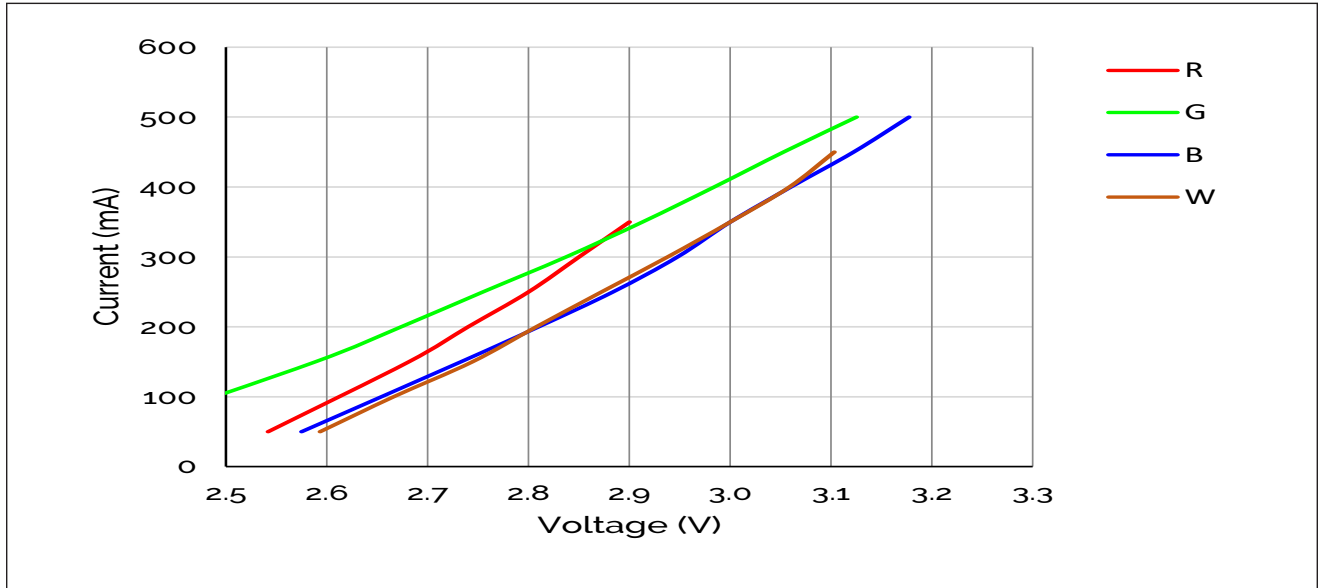
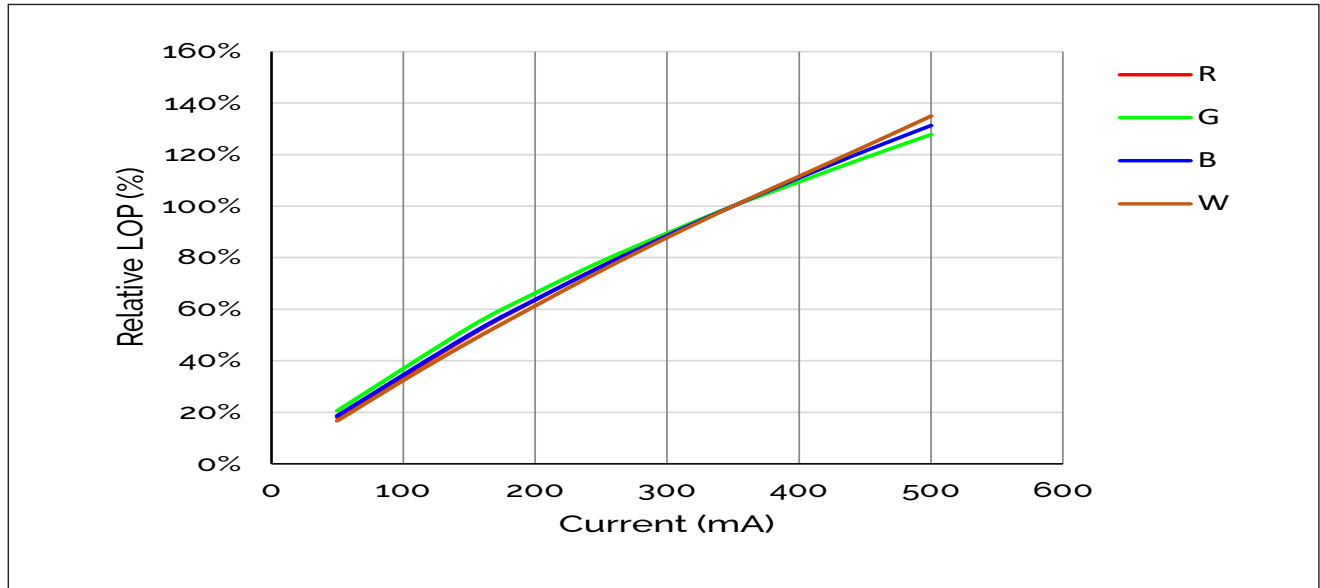

Figure 3: Relative Luminous Flux vs. Drive Current ($T_{sp}=25^{\circ}\text{C}$)



Note for Figure 3:

1. Bridgelux does not recommend driving high power LEDs at low currents. Doing so may produce unpredictable results. Pulse width modulation (PWM) is recommended for dimming effects.

Performance Curves

Figure 4: Relative Flux vs. Solder Point Temperature

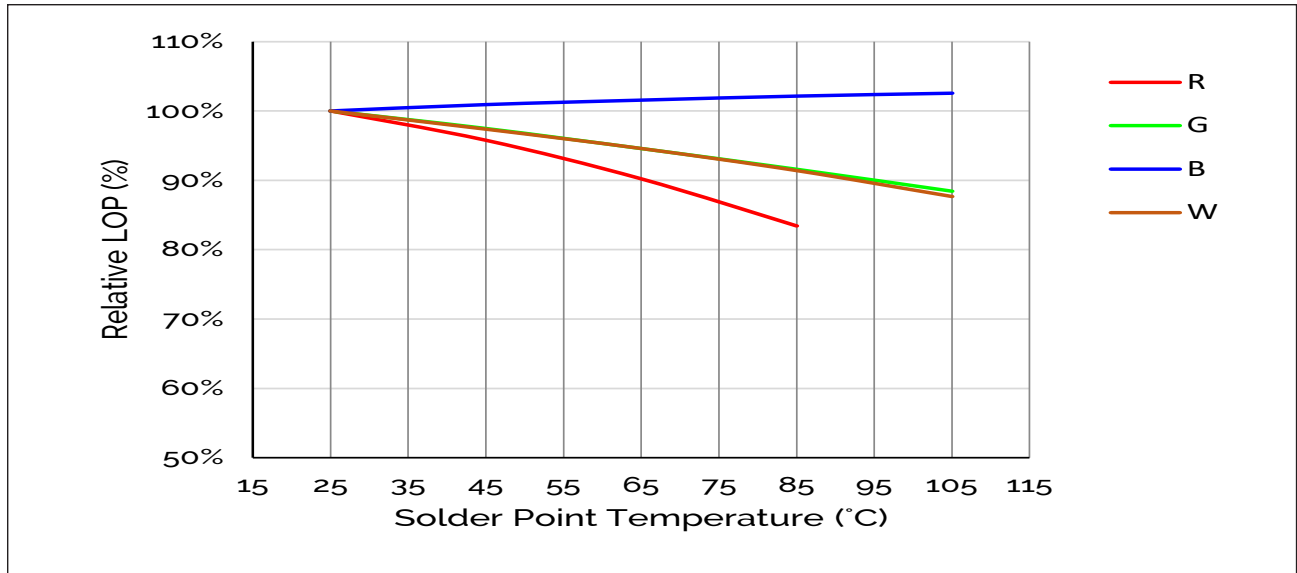

Figure 5: Derating Curve for Red Channel

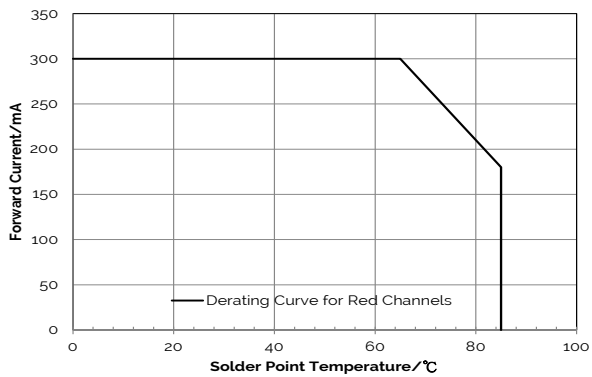
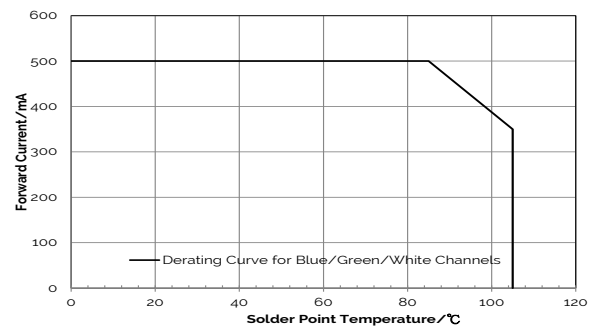

Figure 6: Derating Curve for Blue/Green/White Channels



Performance Curves

Table 12: Current Ratio for Tunable White

CCT Color	1800K	2200K	2400K	2700K	3000K	3500K	4000K	5000K	5700K	6500K	8000K	10000K
B	0.00%	0.81%	1.48%	2.66%	4.02%	6.26%	8.45%	11.82%	14.25%	16.36%	20.20%	23.06%
G	0.46%	0.00%	1.03%	2.95%	4.89%	8.20%	10.30%	15.36%	16.78%	18.65%	21.01%	22.55%
R	68.34%	48.78%	42.69%	35.45%	29.62%	23.70%	20.01%	13.00%	10.32%	7.55%	6.52%	5.07%
W	31.21%	50.41%	54.80%	58.94%	61.47%	61.85%	61.23%	59.82%	58.65%	57.44%	52.26%	49.32%
Total	100.00%	100.00%	100.00%	100.00%	100.00%	100.00%	100.00%	100.00%	100.00%	100.00%	100.00%	100.00%

Figure 7: Chromaticity Coordinate Group (Color Targeted at $T_{sp} = 85^{\circ}\text{C}$)

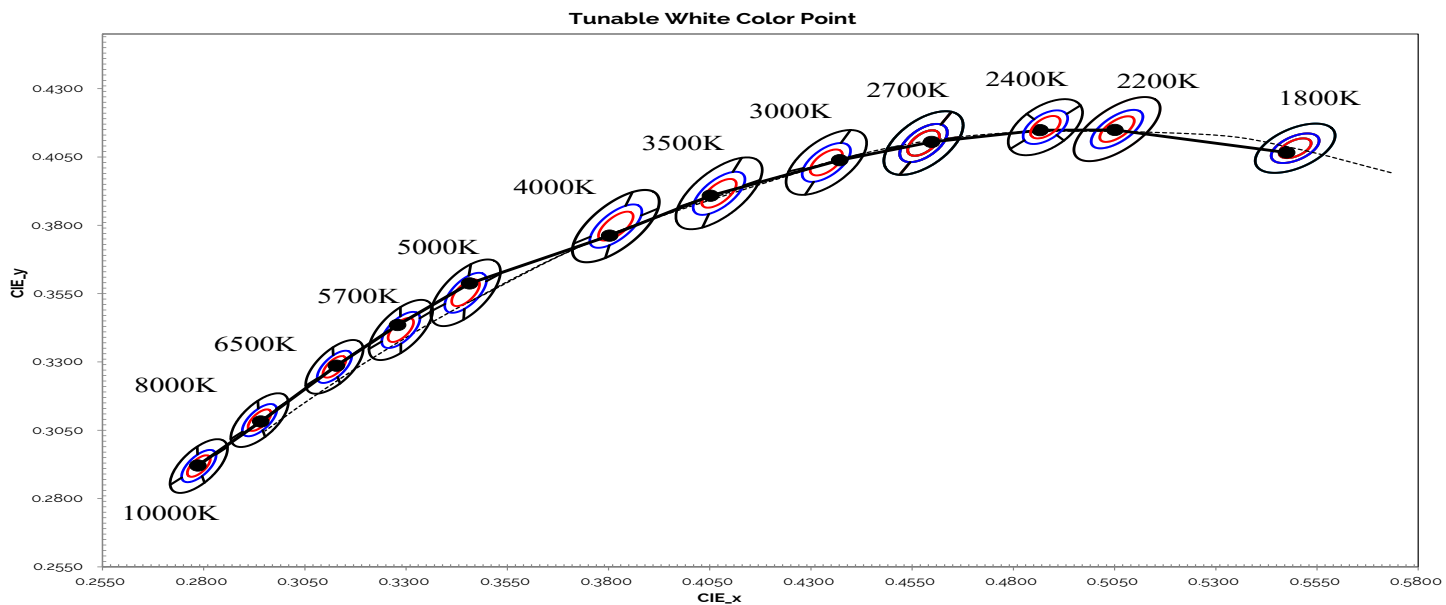

Typical Color Spectrum

Figure 8: Typical Color Spectrum

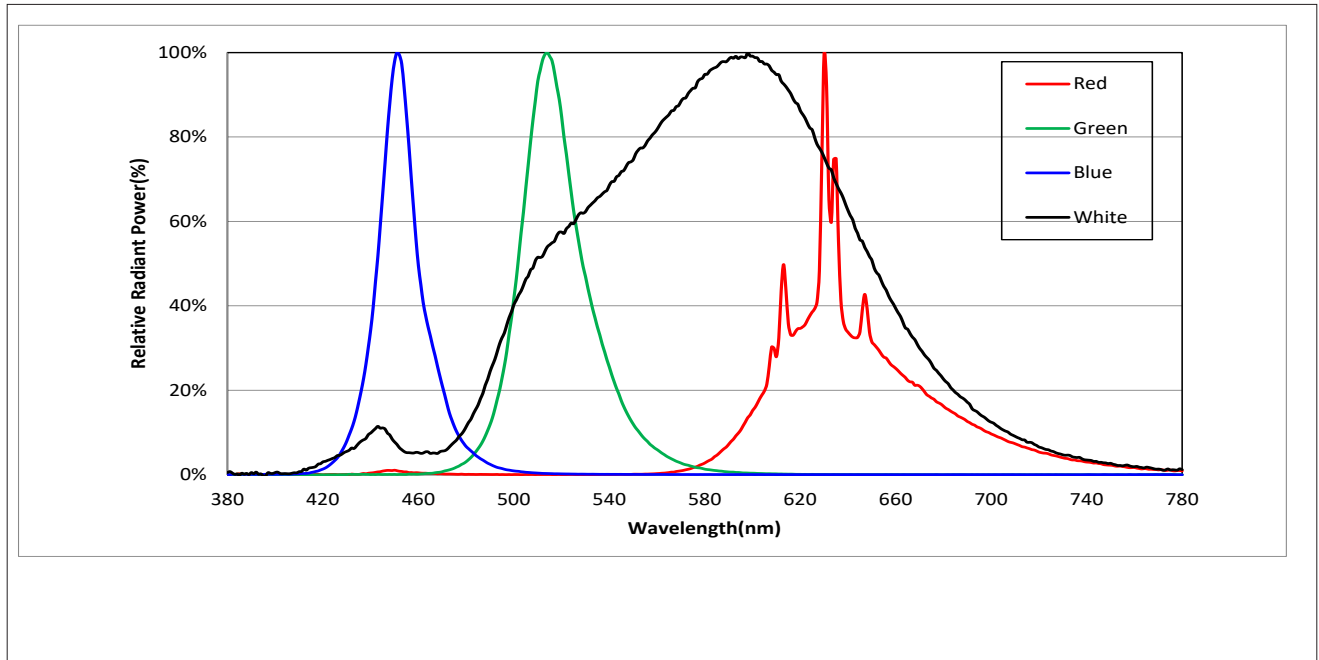

Notes for Figure 8:
Color spectra measured at nominal current for Tsp = 25°C

Mechanical Dimensions

Figure 9: Drawing for CSP 1313

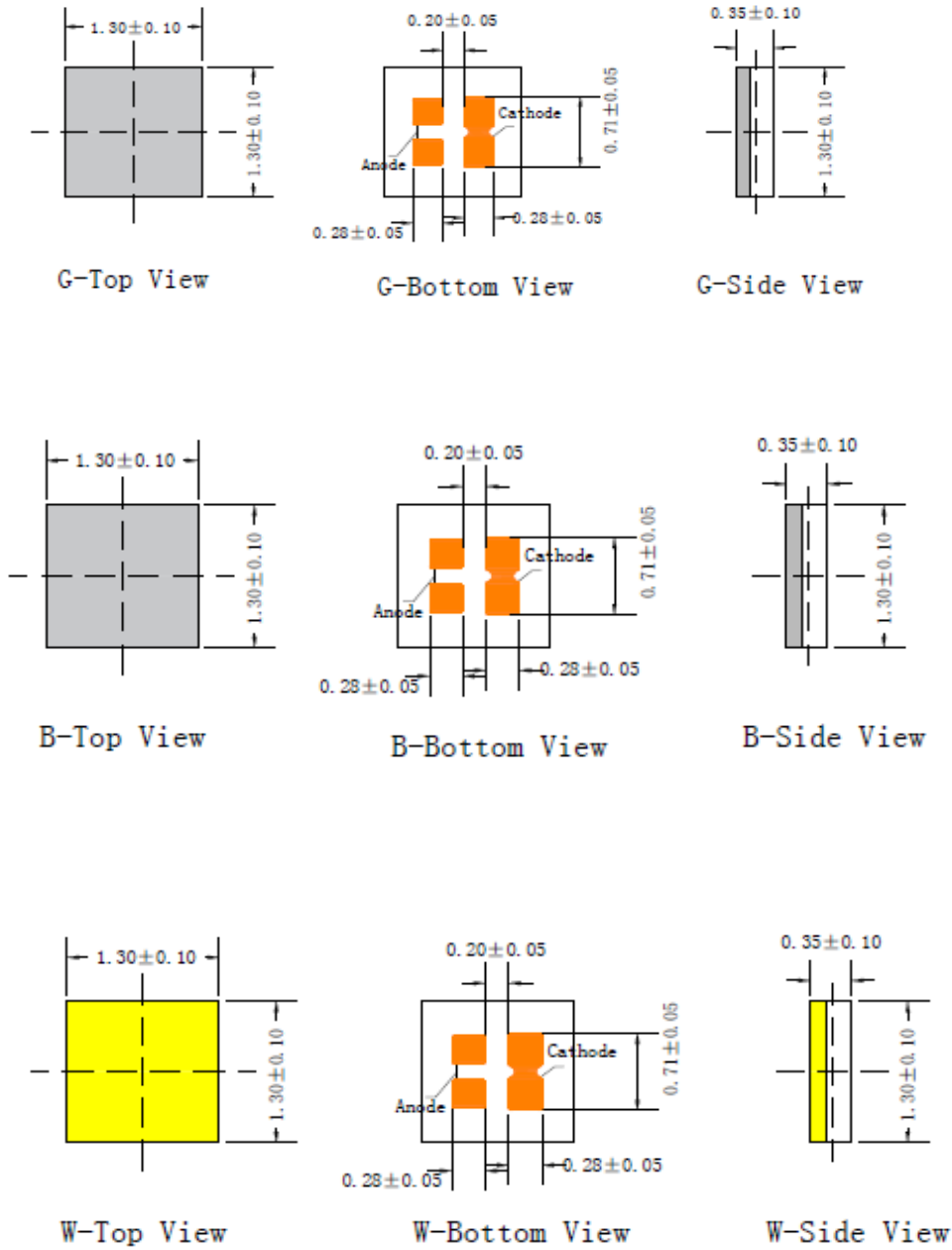

Mechanical Dimensions

Figure 9: Drawing for CSP 1313

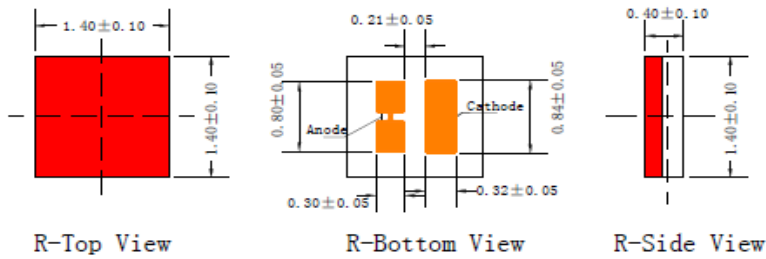

Notes for Figure 9:

1. Drawings are not to scale.
2. Drawing dimensions are in millimeters.
3. Unless otherwise specified, tolerances are ± 0.10 mm.
4. The optical center of the LED emitter is nominally defined by the mechanical center of the emitter. The light emitting surface (LES) is centered on the mechanical center of the LED emitter to a tolerance of ± 0.2 mm

Recommended PCB Soldering Pad Pattern

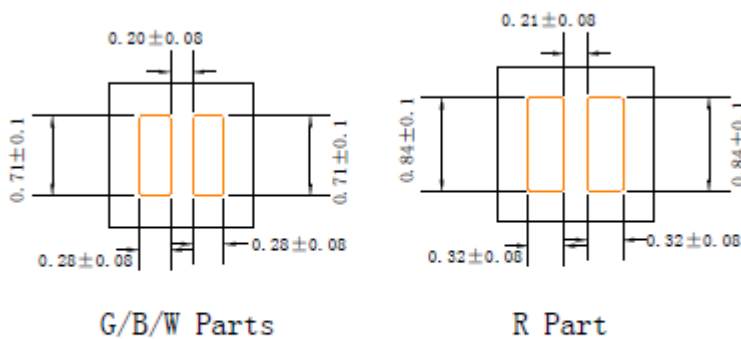

Recommended PCB Pad Pattern

Reflowing Characteristics

Figure 10 : Reflow Profile

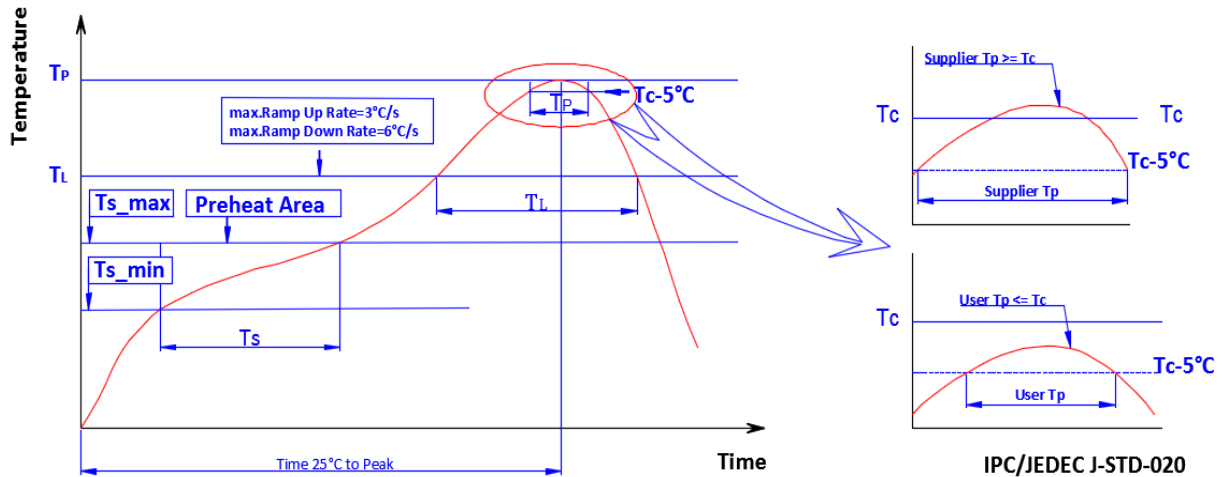

Profile Parameters	Lead-Free Solder SAC305
Average Ramp-Up Rate (T_{s_max} to T_P)	$3^\circ C/second$ max.
Preheat: Temperature Min (T_{s_min})	$150^\circ C$
Preheat: Temperature Max (T_{s_max})	$190^\circ C$
Preheat: Time (t_{s_min} to t_{s_max})	90-120 seconds
Liquidous Temperature (T_L)	$217^\circ C$
Time Maintained Above Liquidous Temperature (T_L): Time (t_L)	60-90 seconds
Peak/Classification Temperature (T_P)	$250-255^\circ C$
Time Within $10^\circ C$ of Actual Peak Temperature (T_P)	20-40 seconds
Ramp-Down Rate	$6^\circ C/second$ max
Time $25^\circ C$ to Peak Temperature	8 minutes max.

Packaging

Figure 11: Reel Drawings

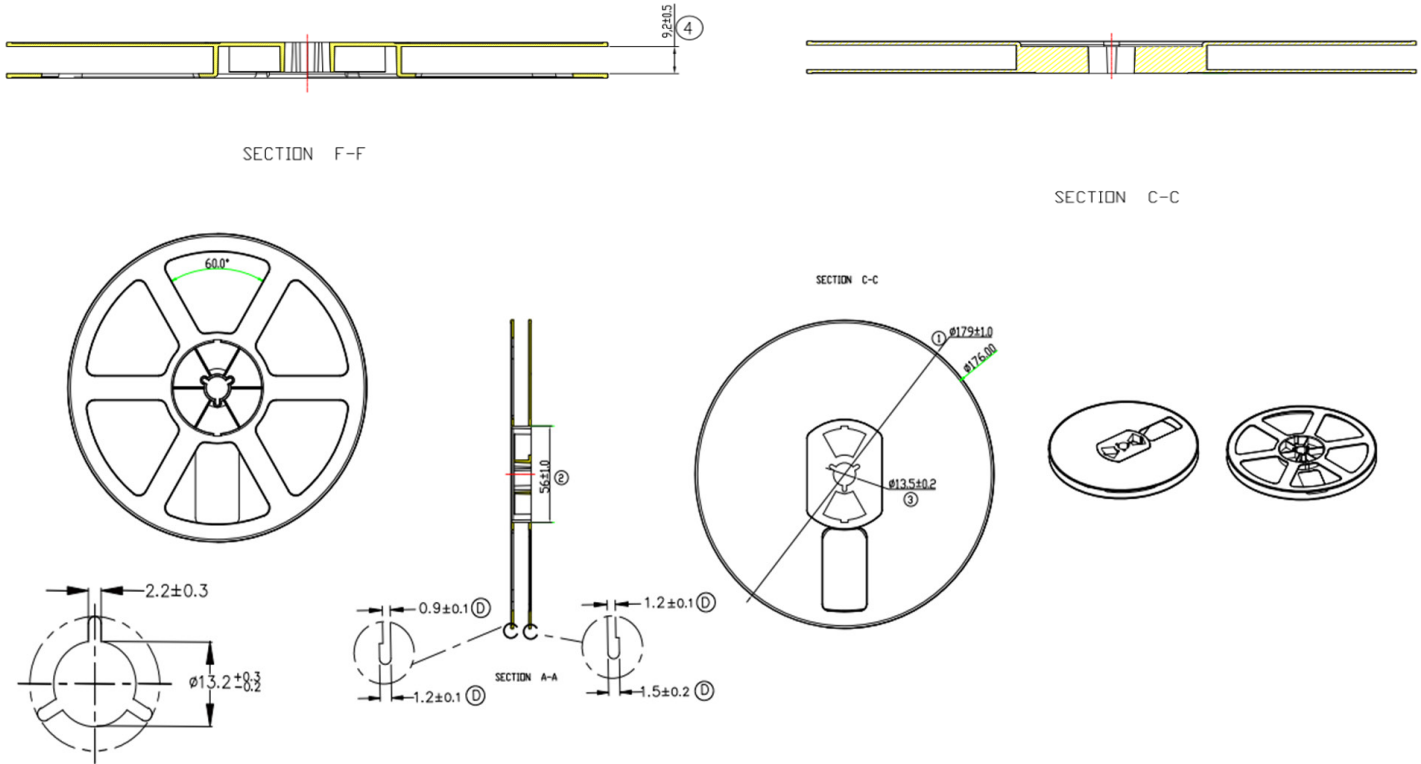

Note for Figure 11:

1. Drawings are not to scale. Drawing dimensions are in millimeters.

Figure 12: Tape Drawings

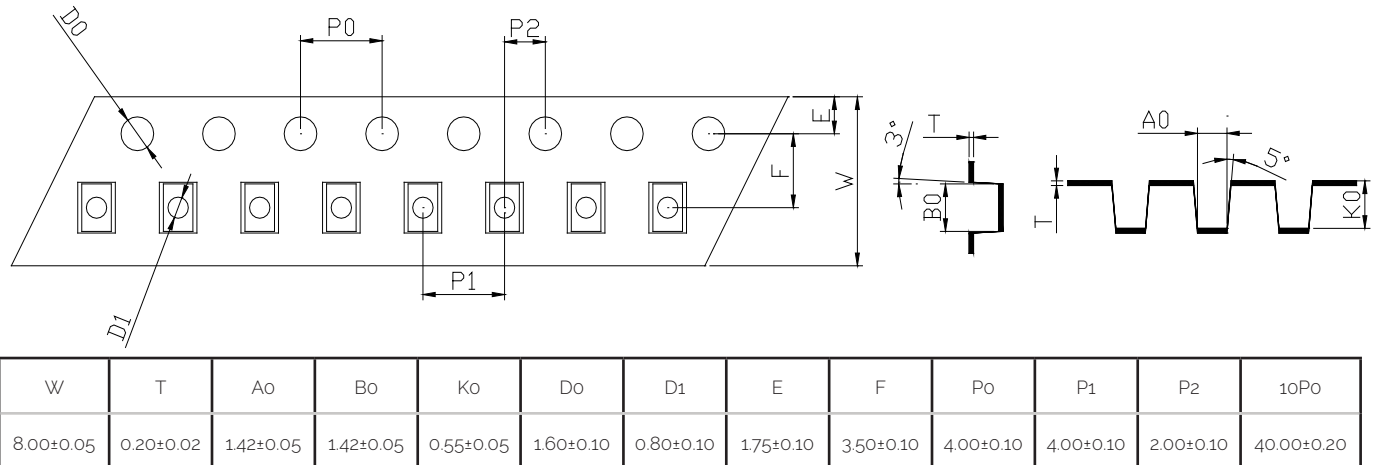

Note for Figure 12:

1. Drawings are not to scale. Drawing dimensions are in millimeters.

Packaging

Figure 13: Reel Packaging Drawings

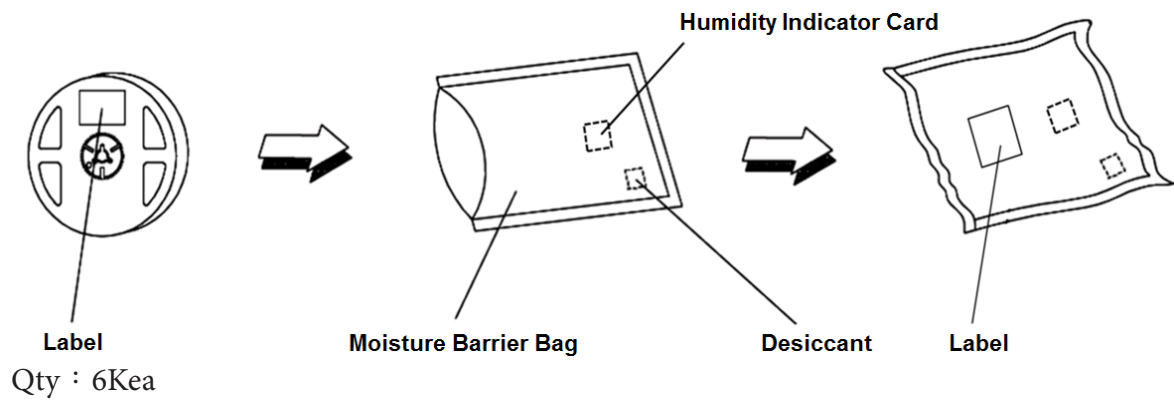

Notes for Figure 13:

1. Drawings are not to scale.
2. LED Quantity of each reel is not less than labeling.
3. Empty cavity of reel is not more than 5ea, continuous empty cavity is not more than 2ea.

Design Resources

Please contact your Bridgelux sales representative for assistance.

Precautions

CAUTION: CHEMICAL EXPOSURE HAZARD

Exposure to some chemicals commonly used in luminaire manufacturing and assembly can cause damage to the LED emitter. Please consult Bridgelux Application Note AN51 for additional information.

CAUTION: EYE SAFETY

Eye safety classification for the use of Bridgelux White CSP LED emitter is in accordance with IEC specification EN62471: Photobiological Safety of Lamps and Lamp Systems. White CSP LED emitters are classified as Risk Group 1 when operated at or below the maximum drive current. Please use appropriate precautions. It is important that employees working with LEDs are trained to use them safely.

CAUTION: RISK OF BURN

Do not touch the CSP LED emitter during operation. Allow the emitter to cool for a sufficient period of time before handling. The CSP LED emitter may reach elevated temperatures such that could burn skin when touched.

CAUTION

CONTACT WITH LIGHT EMITTING SURFACE (LES)

Avoid any contact with the LES. Do not touch the LES of the emitter or apply stress to the LES (yellow phosphor resin area). Contact may cause damage to the emitter

Optics and reflectors must not be mounted in contact with the LES (yellow phosphor resin area).

Disclaimers

MINOR PRODUCT CHANGE POLICY

The rigorous qualification testing on products offered by Bridgelux provides performance assurance. Slight cosmetic changes that do not affect form, fit, or function may occur as Bridgelux continues product optimization.

STANDARD TEST CONDITIONS

Unless otherwise stated, LED emitter testing is performed at the nominal drive current.

About Bridgelux: Bridging Light and Life™

At Bridgelux, we help companies, industries and people experience the power and possibility of light. Since 2002, we've designed LED solutions that are high performing, energy efficient, cost effective and easy to integrate. Our focus is on light's impact on human behavior, delivering products that create better environments, experiences and returns—both experiential and financial. And our patented technology drives new platforms for commercial and industrial luminaires.

For more information about the company, please visit
bridgelux.com
twitter.com/Bridgelux
facebook.com/Bridgelux
youtube.com/user/Bridgelux
WeChat ID: BridgeluxInChina
https://www.linkedin.com/company/bridgelux-inc-_2



46410 Fremont Boulevard
Fremont, CA 94538 USA
Tel (925) 583-8400
Fax (925) 583-8401
www.bridgelux.com

© 2025 Bridgelux, Inc. All rights reserved 2023. Product specifications are subject to change without notice. Bridgelux and the Bridgelux stylized logo design are registered trademarks of Bridgelux, Inc. All other trademarks are the property of their respective owners.