



US009845926B2

(12) **United States Patent**  
**Odnoblyudov**

(10) **Patent No.:** **US 9,845,926 B2**  
(45) **Date of Patent:** **Dec. 19, 2017**

(54) **LINEAR LED MODULE**

(2016.08); *F21Y 2115/10* (2016.08); *H01L 2224/14* (2013.01); *H01L 2224/16225* (2013.01)

(71) Applicant: **BRIDGELUX, INC.**, Livermore, CA (US)

(58) **Field of Classification Search**

(72) Inventor: **Vladimir Odnoblyudov**, Danville, CA (US)

CPC ..... *F21Y 2103/00*; *F21Y 2103/03*; *F21Y 2101/02*; *F21V 7/005*; *F21V 3/049*; *F21V 23/005*; *F21V 7/22*; *H01L 23/4985*; *F21S 8/04*

(73) Assignee: **BRIDGELUX INC.**, Fremont, CA (US)

USPC ..... *362/217.4*, *223*, *249.02*, *241*, *225*, *236*, *362/362*, *218*, *145*, *217.17*, *240*, *222*, *184*, *362/351*, *311.02*

(\*) Notice: Subject to any disclaimer, the term of this patent is extended or adjusted under 35 U.S.C. 154(b) by 0 days.

See application file for complete search history.

(21) Appl. No.: **15/063,263**

(56) **References Cited**

(22) Filed: **Mar. 7, 2016**

U.S. PATENT DOCUMENTS

(65) **Prior Publication Data**

US 2016/0186941 A1 Jun. 30, 2016

6,361,186 B1	3/2002	Slayden	
7,506,997 B1	3/2009	Eriksson	
8,177,391 B2	5/2012	Ryu et al.	
8,556,453 B1 *	10/2013	Crane	F21S 8/026
			362/217.01
2003/0025457 A1 *	2/2003	Tai	A01K 63/06
			315/61
2009/0261368 A1	10/2009	Wang et al.	
2009/0267104 A1	10/2009	Hsu et al.	
2009/0323334 A1	12/2009	Roberts et al.	

**Related U.S. Application Data**

(63) Continuation of application No. 14/450,111, filed on Aug. 1, 2014, now Pat. No. 9,310,045.

(Continued)  
*Primary Examiner* — Joseph L Williams  
*Assistant Examiner* — Jose M Diaz

(51) **Int. Cl.**

- F21V 3/04* (2006.01)
- F21S 4/24* (2016.01)
- F21V 23/00* (2015.01)
- F21V 7/22* (2006.01)
- F21S 8/04* (2006.01)
- F21V 7/05* (2006.01)
- F21V 23/06* (2006.01)
- F21Y 103/10* (2016.01)
- F21Y 115/10* (2016.01)

(74) *Attorney, Agent, or Firm* — Arent Fox LLP

(52) **U.S. Cl.**

CPC . *F21S 4/24* (2016.01); *F21S 8/04* (2013.01);  
*F21V 3/049* (2013.01); *F21V 7/05* (2013.01);  
*F21V 7/22* (2013.01); *F21V 23/005* (2013.01);  
*F21V 23/06* (2013.01); *F21Y 2103/10*

(57) **ABSTRACT**

Various aspects of a light emitting apparatus include a substrate having at least one angled portion. Some aspects of the light emitting apparatus include at least one light emitting device arranged on the substrate. Some aspects of the light emitting apparatus include a plurality of conductors arranged on the substrate. In some aspects of the light emitting apparatus, the conductors are electrically coupled to the at least one light emitting device.

**18 Claims, 4 Drawing Sheets**

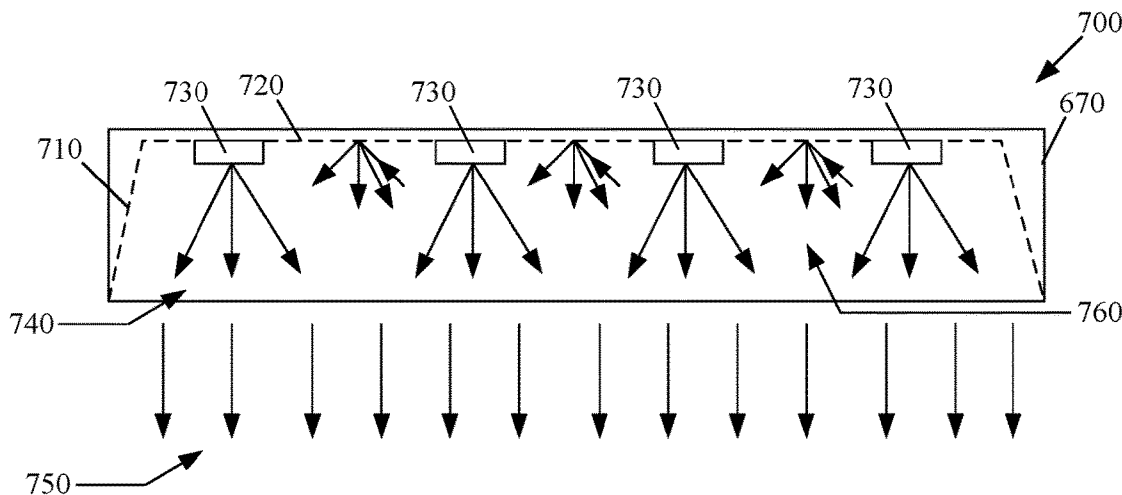

(56)

**References Cited**

U.S. PATENT DOCUMENTS

2010/0142215	A1	6/2010	Waring	
2012/0057336	A1	3/2012	Farmer	
2012/0162978	A1	6/2012	Farmer	
2013/0039050	A1	2/2013	Dau et al.	
2013/0242550	A1	9/2013	Suen et al.	
2013/0265751	A1*	10/2013	Edmond .....	F21S 8/026 362/231
2014/0104818	A1	4/2014	Khojasteh et al.	
2014/0111982	A1	4/2014	Kuenzler	
2014/0167598	A1	6/2014	Chen et al.	
2014/0168961	A1	6/2014	Dubord	
2014/0225152	A1	8/2014	Asahi et al.	
2015/0003065	A1	1/2015	Chen et al.	
2015/0016108	A1	1/2015	Howe	
2015/0097277	A1	4/2015	Chen et al.	
2015/0200230	A1	7/2015	Jang et al.	
2016/0252219	A1*	9/2016	Hikmet .....	F21K 9/56

\* cited by examiner

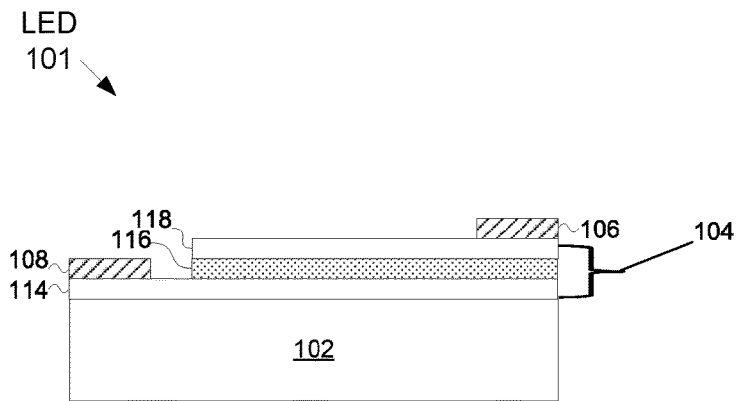

FIG. 1

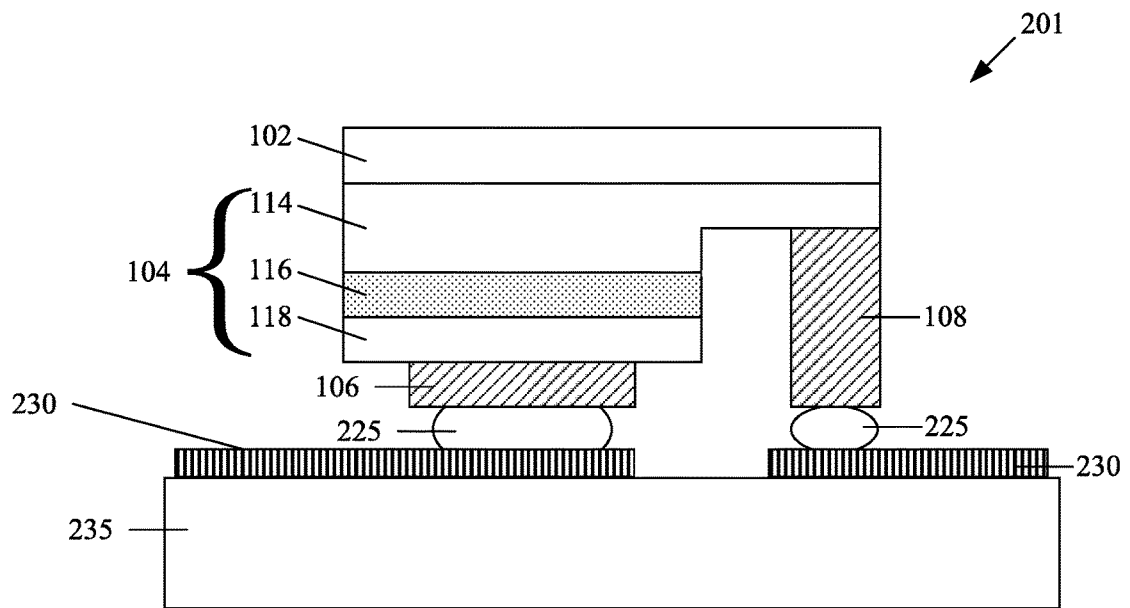
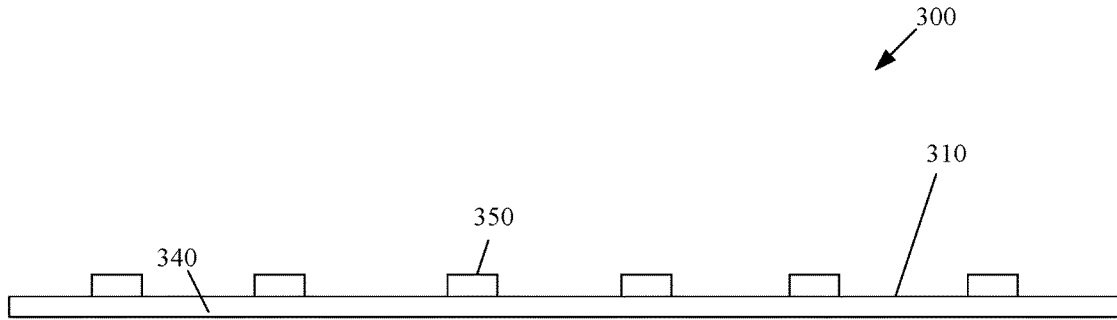
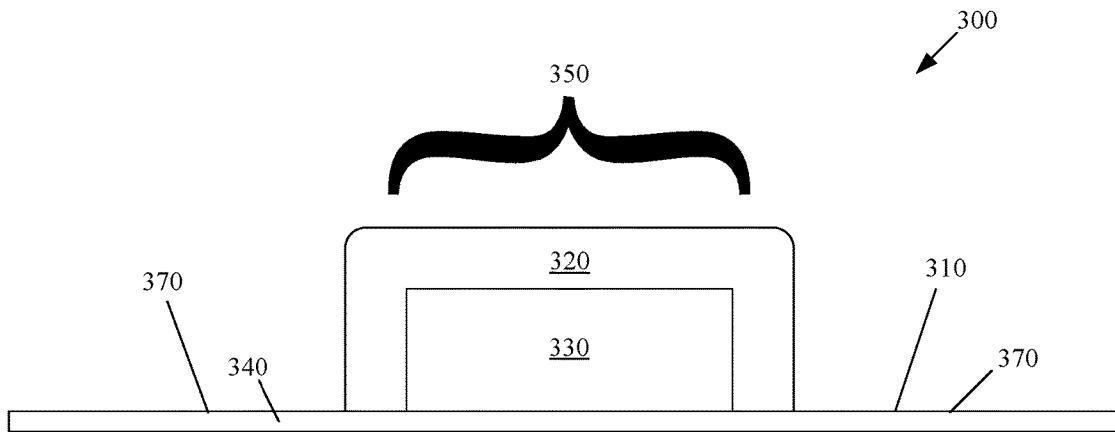

FIG. 2



**FIG. 3a**



**FIG. 3b**

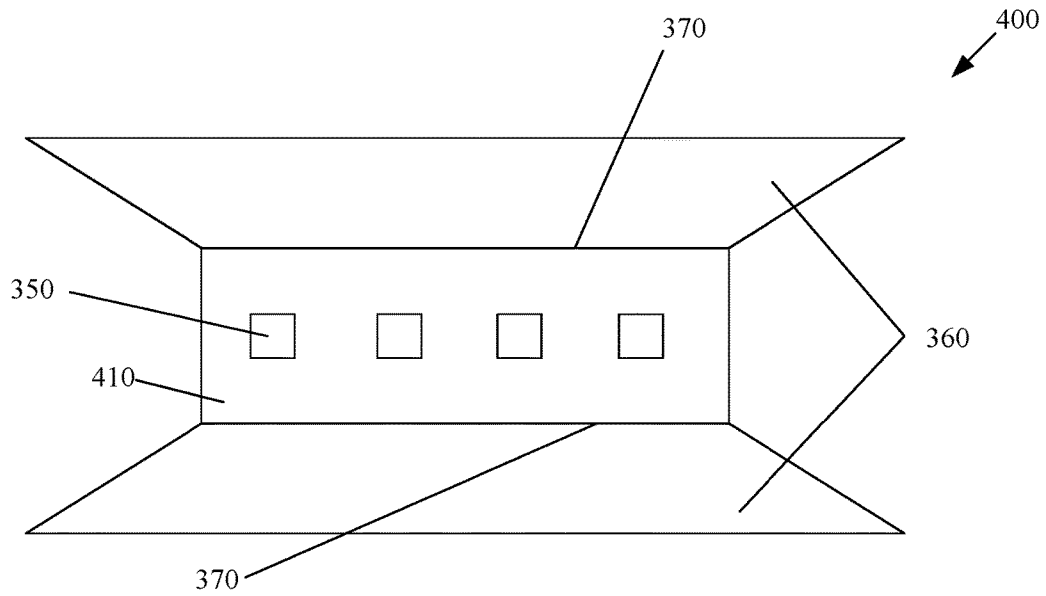

**FIG. 4a**

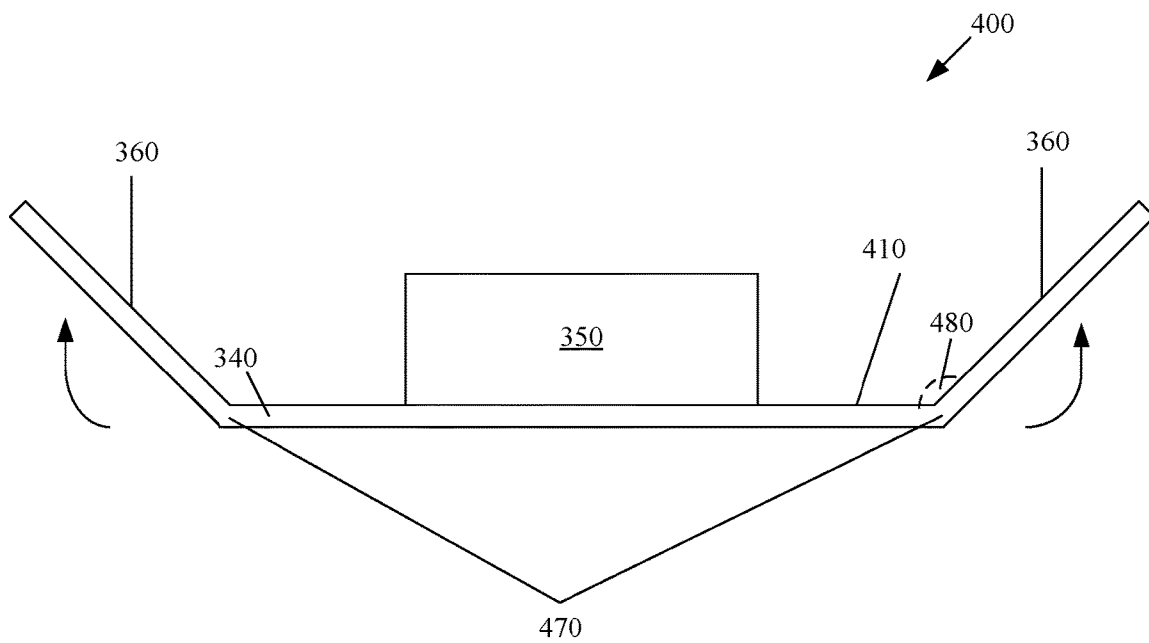

**FIG. 4b**

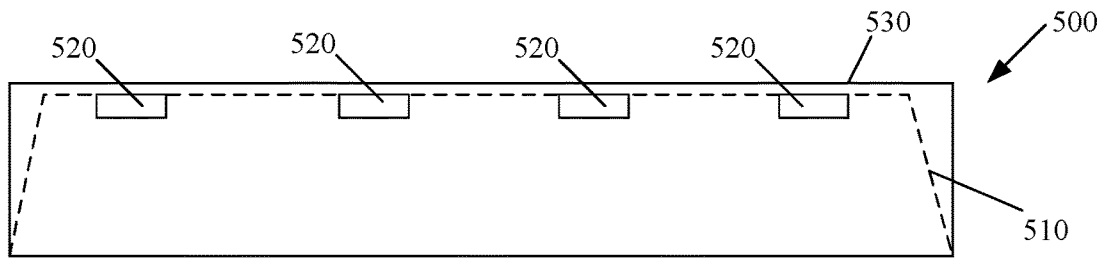

**FIG. 5**

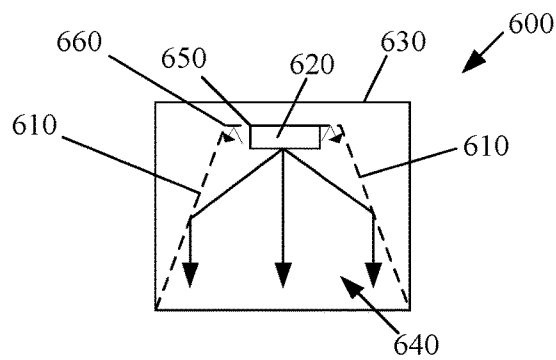

**FIG. 6**

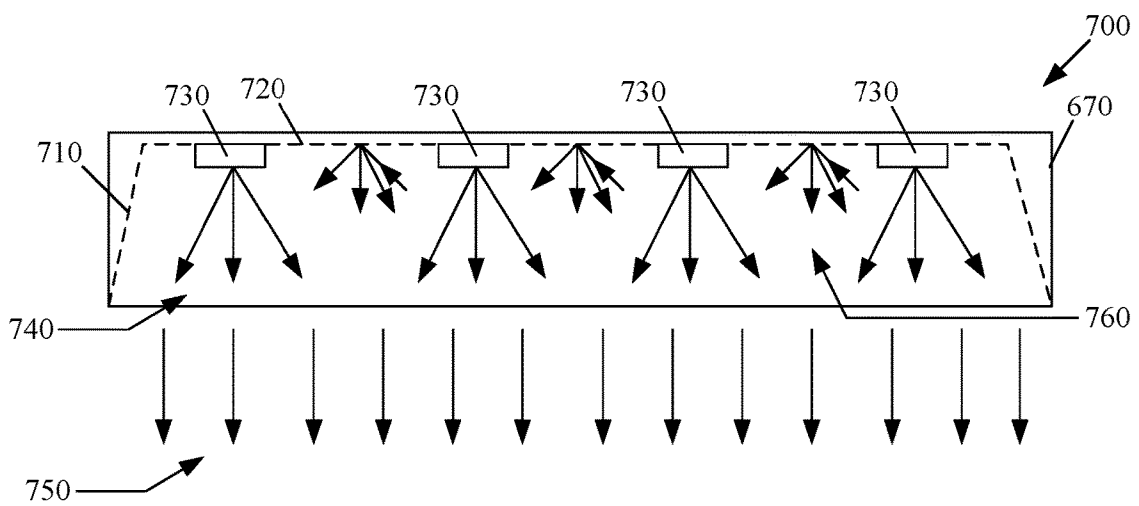

**FIG. 7**

**LINEAR LED MODULE****CROSS-REFERENCE TO RELATED APPLICATIONS**

This Application is a continuation of U.S. patent application Ser. No. 14/450,111 entitled "Linear LED Module," filed Aug. 1, 2014, allowed, the contents of which are hereby incorporated by reference herein their entirety.

**BACKGROUND****Field**

The present disclosure relates generally to a linear LED module and, more particularly, to a linear LED module that uses a flexible substrate with angled portions.

**Background**

Solid state light emitting devices, such as light emitting diodes (LEDs), are attractive candidates for replacing conventional light sources such as incandescent, halogen, and fluorescent lamps. LEDs have substantially longer lifetimes than all three of these types of conventional light sources. In addition, some types of LEDs now have higher conversion efficiencies than fluorescent light sources and still higher conversion efficiencies have been demonstrated in laboratories. Finally, LEDs contain no mercury or other potentially dangerous materials, therefore, providing various safety and environmental benefits.

A troffer is a light fixture resembling an inverted trough that is either recessed in, or suspended from, the ceiling. Troffers are typically designed to emit light using fluorescent lighting tubes. The fluorescent tubes emit light along the entire length of the troffer to produce a focused light distribution pattern. However, fluorescent lighting tubes may be expensive, require a warm up period, and produce flicker that is undesirable.

More recently, solid state light emitting devices have been used to replace fluorescent lamps conventionally used in troffer assemblies. LEDs are attractive candidates for replacing fluorescent lighting tubes because LEDs have no warm up time, are long lasting and power efficient, and do not flicker. Troffer assemblies with LED light sources are sometimes referred to as linear LED modules, and conventional linear LED modules have been widely utilized in the global troffer market.

Typically, conventional linear LED designs utilize rigid FR4 or Metal Core Printed Circuit Board (MCPCB) substrates coated with a white solder mask for light reflection and diffusion. Such boards are commonly mounted on rigid metal plates (such as aluminum) with reflective sides for directing light down into a diffuser lens and out of the metal troffer tube. The metal plate sometimes also doubles as a heat sink.

The conventional linear LED assembly can be expensive, heavy, and overly complex. It is therefore difficult to design a linear LED assembly that is both cost efficient, lightweight, and is not overly complex.

**SUMMARY**

Several aspects of the present invention will be described more fully hereinafter with reference to various apparatuses.

One aspect of a light emitting apparatus includes a substrate having at least one angled portion. The light emitting apparatus includes at least one light emitting device arranged on the substrate. The light emitting apparatus

includes a plurality of conductors arranged on the substrate. The conductors are electrically coupled to the at least one light emitting device.

Another aspect of the light emitting apparatus includes at least one light emitting device. The light emitting apparatus includes a flexible substrate having a member supporting the at least one light emitting device. The light emitting apparatus includes an angled portion extending from the member.

An aspect of a lamp includes a housing. The lamp includes a light emitting apparatus coupled to the housing. The light emitting apparatus includes at least one light emitting device. The light emitting apparatus includes a flexible substrate carried by the housing. The flexible substrate includes a reflective portion and a diffusive portion, wherein the at least one light emitting device is arranged on the diffusive portion.

**BRIEF DESCRIPTION OF THE DRAWINGS**

The various aspects of the present invention illustrated in the drawings may not be drawn to scale. Rather, the dimensions of the various features may be expanded or reduced for clarity. In addition, some of the drawings may be simplified for clarity. Thus, the drawings may not depict all of the components of a given apparatus or method.

Various aspects of the present invention will be described herein with reference to drawings that are schematic illustrations of idealized configurations of the present invention. As such, variations from the shapes of the illustrations as a result, for example, manufacturing techniques and/or tolerances, are to be expected. Thus, the various aspects of the present invention presented throughout this disclosure should not be construed as limited to the particular shapes of elements (e.g., regions, layers, sections, substrates, bulb shapes, etc.) illustrated and described herein but are to include deviations in shapes that result, for example, from manufacturing. By way of example, an element illustrated or described as a rectangle may have rounded or curved features and/or a gradient concentration at its edges rather than a discrete change from one element to another. Thus, the elements illustrated in the drawings are schematic in nature and their shapes are not intended to illustrate the precise shape of an element and are not intended to limit the scope of the present invention.

Various aspects of apparatuses will now be presented in the detailed description by way of example, and not by way of limitation, with reference to the accompanying drawings, wherein:

FIG. 1 illustrates an exemplary embodiment of an LED

FIG. 2 illustrates an exemplary embodiment of an LED chip having a flip-chip architecture.

FIG. 3a illustrates a plan view of an exemplary embodiment of a light emitting apparatus having several LEDs arranged on a flexible substrate.

FIG. 3b illustrates a cross-section view of an exemplary embodiment of a light emitting apparatus having an encapsulated LED arranged on a flexible substrate.

FIG. 4a illustrates a top view of an exemplary embodiment of a light emitting apparatus having several LEDs arranged on a flexible substrate.

FIG. 4b illustrates a cross-section view of an exemplary embodiment of a light emitting apparatus having the flexible substrate of FIG. 4a.

FIG. 5 illustrates a cross-section view of a troffer device of an exemplary embodiment of the light emitting device having a flexible substrate.

FIG. 6 illustrates a side view of a troffer device of an exemplary embodiment of the light emitting device.

FIG. 7 illustrates a cross-section view of a troffer device that provides light distribution pattern.

#### DETAILED DESCRIPTION

The detailed description set forth below in connection with the appended drawings is intended as a description of various exemplary embodiments of the present invention and is not intended to represent the only embodiments in which the present invention may be practiced. The detailed description includes specific details for the purpose of providing a thorough understanding of the present invention. However, it will be apparent to those skilled in the art that the present invention may be practiced without these specific details. In some instances, well-known structures and components are shown in block diagram form in order to avoid obscuring the concepts of the present invention. Acronyms and other descriptive terminology may be used merely for convenience and clarity and are not intended to limit the scope of the invention.

The word “exemplary” is used herein to mean serving as an example, instance, or illustration. Any embodiment described herein as “exemplary” is not necessarily to be construed as preferred or advantageous over other embodiments. Likewise, the term “embodiment” of an apparatus, method or article of manufacture does not require that all embodiments of the invention include the described components, structure, features, functionality, processes, advantages, benefits, or modes of operation.

The various aspects of the present invention illustrated in the drawings may not be drawn to scale. Rather, the dimensions of the various features may be expanded or reduced for clarity. In addition, some of the drawings may be simplified for clarity. Thus, the drawings may not depict all of the components of a given apparatus or method. Various aspects of the present invention will be described herein with reference to drawings that are schematic illustrations of idealized configurations of the present invention. As such, variations from the shapes of the illustrations as a result, for example, manufacturing techniques and/or tolerances, are to be expected. Thus, the various aspects of the present invention presented throughout this disclosure should not be construed as limited to the particular shapes of elements (e.g., regions, layers, sections, substrates, etc.) illustrated and described herein but are to include deviations in shapes that result, for example, from manufacturing. By way of example, an element illustrated or described as a rectangle may have rounded or curved features and/or a gradient concentration at its edges rather than a discrete change from one element to another. Thus, the elements illustrated in the drawings are schematic in nature and their shapes are not intended to illustrate the precise shape of an element and are not intended to limit the scope of the present invention.

It will be understood that when an element such as a region, layer, section, substrate, or the like, is referred to as being “on” another element, it can be directly on the other element or intervening elements may also be present. In contrast, when an element is referred to as being “directly on” another element, there are no intervening elements present. It will be further understood that when an element is referred to as being “formed” on another element, it can be grown, deposited, etched, attached, connected, coupled, or otherwise prepared or fabricated on the other element or an intervening element.

Furthermore, relative terms, such as “beneath” or “bottom” and “above” or “top,” may be used herein to describe one element’s relationship to another element as illustrated in the drawings. It will be understood that relative terms are intended to encompass different orientations of an apparatus in addition to the orientation depicted in the drawings. By way of example, if an apparatus in the drawings is turned over, elements described as being “above” other elements would then be oriented “below” other elements and vice versa. The term “above”, can therefore, encompass both an orientation of “above” and “below,” depending of the particular orientation of the apparatus. Similarly, if an apparatus in the drawing is turned over, elements described as “below” other elements would then be oriented “above” the other elements. The terms “below” can, therefore, encompass both an orientation of above and below.

It will be further understood that the terms “comprises” and/or “comprising,” when used in this specification, specify the presence of stated features, steps, operations, elements, and/or components, but do not preclude the presence or addition of one or more other features, integers, steps, operations, elements, components, and/or groups thereof. The term “and/or” includes any and all combinations of one or more of the associated listed items.

Unless otherwise defined, all terms (including technical and scientific terms) used herein have the same meaning as commonly understood by a person having ordinary skill in the art to which this invention belongs. It will be further understood that terms, such as those defined in commonly used dictionaries, should be interpreted as having a meaning that is consistent with their meaning in the context of the relevant art and the present disclosure and will not be interpreted in an idealized or overly formal sense unless expressly so defined herein.

In the following detailed description, various aspects of the present invention will be presented in the context of a light-emitting device. A light-emitting die shall be construed broadly to include any suitable solid state light source such as, by way of example, a light emitting diode (LED) or other solid state material which releases photons or light through the recombination of electrons and holes flowing across a p-n junction. Accordingly, any reference to an LED or light throughout this disclosure is intended only to illustrate the various aspects of the present invention, with the understanding that such aspects may have a wide range of applications.

The following description describes a linear LED module that is designed to minimize cost while providing the same efficacy as conventional linear LED modules. The linear LED module utilizes a flexible substrate, which will be described in greater detail below. The flexible substrate minimizes the complexity associated with designing linear LED modules for troffer devices by providing bendable portions which can be adjusted to fit most designs. Moreover, the flexible substrate negates the need for a rigid substrate coupled to a heavy reflector. The flexible substrate is capable of providing the same directed light effect of both the rigid substrate and attached reflector, but at a lower cost. As will be discussed in greater detail below, several LEDs having different designs may be arranged on the flexible substrate. FIG. 1 is an example of one such LED design.

FIG. 1 illustrates an exemplary embodiment of an LED 101. An LED is a semiconductor material impregnated, or doped, with impurities. These impurities add “electrons” or “holes” to the semiconductor, which can move in the material relatively freely. Depending on the kind of impurity, a doped region of the semiconductor can have predominantly



electrons or holes, and is referred respectively as n-type or p-type semiconductor regions.

Referring to FIG. 1, the LED 101 includes an n-type semiconductor region 114 and a p-type semiconductor region 118. A reverse electric field is created at the junction between the two regions, which cause the electrons and holes to move away from the junction to form an active region 116. When a forward voltage sufficient to overcome the reverse electric field is applied across the p-n junction through a pair of electrodes 108, 106, electrons and holes are forced into the active region 116 and recombine. When electrons recombine with holes, they fall to lower energy levels and release energy in the form of light.

In this example, the n-type semiconductor region 114 is formed on a substrate 102 and the p-type semiconductor region 118 is formed on the active layer 116, however, the regions may be reversed. That is, the p-type semiconductor region 118 may be formed on the substrate 102 and the n-type semiconductor region 114 may be formed on the active layer 116. As those skilled in the art will readily appreciate, the various concepts described throughout this disclosure may be extended to any suitable layered structure. Additional layers or regions (not shown) may also be included in the LED 101, including but not limited to buffer, nucleation, contact and current spreading layers or regions, as well as light extraction layers.

The p-type semiconductor region 118 is exposed at the top surface, and therefore, the p-type electrode 106 may be readily formed thereon. However, the n-type semiconductor region 114 is buried beneath the p-type semiconductor layer 118 and the active layer 116. Accordingly, to form the n-type electrode 108 on the n-type semiconductor region 114, a cutout area or "mesa" is formed by removing a portion of the active layer 116 and the p-type semiconductor region 118 by means well known in the art to expose the n-type semiconductor layer 114 there beneath. After this portion is removed, the n-type electrode 108 may be formed.

FIG. 2 illustrates an exemplary embodiment of an LED chip having a flip-chip architecture. Flip-chip LED 201 includes similar features of the LED illustrated in FIG. 1. However, the features are flipped over. For instance, electrodes 106 and 108 are positioned beneath p-type semiconductor region 118 and n-type semiconductor region 114 rather than above the p-type semiconductor region 118 and n-type semiconductor region 114 as shown in FIG. 1. As a result solders 225 couple the flip-chip LED 201 to conductive layer 230. The conductive layer is arranged over substrate 235. As will be discussed in greater detail in the following sections, the substrate 235 may be a flexible substrate capable of being bent into different configurations.

FIG. 3a illustrates a plan view of an exemplary embodiment of a light emitting apparatus 300 having several LEDs 350 arranged on a flexible substrate 340. An example of a flexible substrate 340 is an Al substrate having a thickness between 0.1 mm and 0.5 mm. Alternatively, the substrate 340 may be a multi-layer structure having a similar thickness between 0.1 mm and 0.5 mm. The multi-layer structure may be formed with two Al layers separated by a dielectric layer, Al and Cu layers separated by a dielectric layer, two Cu layers separated by a dielectric layer, or some other suitable layered structure. Those skilled in the art will be readily able to determine the appropriate material and thickness of the material to produce a flexible substrate suitable for any particular application.

The plan view includes LEDs 350, flexible substrate 340 and a top surface of the flexible substrate 310. The LEDs 350, in some aspects of the apparatus, may be lateral LEDs

such as the LED architecture described with respect to FIG. 1 or flip-chip LEDs such as the LED architecture described with respect to FIG. 2. The flexible substrate 340 of some aspects of the apparatus may be manufactured using a reel-to-reel process. The reel-to-reel process involves creating an electronic device (or substrate) on a roll of flexible plastic or metal foil. LEDs are then mounted to the substrate. In the example shown in FIG. 3a, the substrate 340 may be an aluminum substrate manufactured using the reel-to-reel process.

As will be shown in greater detail in the following drawings, the LED 350 may be a chip on board package that is mounted directly to the substrate 340. In addition, the LEDs 350 may be lateral LEDs or flip-chip LEDs. The substrate 340 may also include conductors 310 to interconnect the LEDs 350. An insulation layer (not shown) may be formed between the substrate 334 and the conductors 310 to electrically insulate the two.

In one embodiment, the top surface of the substrate 340 may include a reflective layer (not shown). An insulation layer (not shown) may be formed between the reflective layer and the conductors 310 with vias to provide electrical connections between the conductors 310 and the LEDs 350. In an alternative embodiment, the reflective layer may be an insulator, thereby eliminating the need for a separate insulation layer between the reflective layer and the conductors 310. By way of example, the reflective layer may be a white solder mask such as those manufactured by Taiyo America or other manufacturers.

The substrate 340 provides a thinner lightweight substrate for linear LEDs, which is more customizable and cost efficient. The substrate 340 replaces the need for a heavy reflector and rigid substrate combination. Thus, the flexible substrate provides a less complex design that produces the same directed lighting effect.

FIG. 3b illustrates a cross-section view of an exemplary embodiment of a light emitting apparatus 300 having an encapsulated LED arranged on a flexible substrate. In some aspects of the apparatus, FIG. 3b is a cross-sectional view of the light emitting apparatus illustrated in FIG. 3a. Similar to FIG. 3a, the cross-sectional view includes the LED 350, the flexible substrate 340, and the top surface of the flexible substrate 310. The cross-sectional view additionally includes bending points 370. The LED 350 includes a flip-chip LED 330 and an encapsulant 320, forming a chip-on-board package. In some aspects of the apparatus, a phosphor may also be disposed over LED 330 and the encapsulant may be a lens. Although this exemplary view includes a flip-chip LED 330, any suitable LED design could be mounted on the substrate 340. Furthermore, the design illustrated in FIGS. 3a and 3b is not only limited to chip-on-board packages.

The flexible substrate 340 is configured to bend at bending points 370. The ability to bend the flexible substrate 340 at the bending points 370 replaces the need for a reflector in addition to the rigid substrate used in conventional linear LED modules. Additionally, the angle of the bend can be customized, making the same flexible substrate 340 capable of accommodating different troffer designs. By bending the flexible substrate 340, the light emitting apparatus may be capable of focusing light in a downward direction to a diffusive lens, which is typically used in troffer assemblies.

FIG. 4a illustrates a top view of an exemplary embodiment of a light emitting apparatus 400 having several LEDs arranged on a flexible substrate. FIG. 4a includes similar features to those already discussed with respect to FIGS. 3a

and **3b**. However, FIG. **4a** differs from FIGS. **3a** and **3b** in that it includes angled portions **360** that have been bent up at bending points **370**.

As discussed above portions of the substrate **340** may include reflective surfaces. In this example, angled portions **360** may include the reflective portions of the substrate. The top portion **410** of the substrate that is between the bending points **370** may include the diffusive layer. However, as discussed above, the angled portions **360** and horizontal surface **410** may have a diffusive material layered above the surface such as a white solder mask. In some aspects of the apparatus, the diffusive material may be printed around the LEDs **350** on the horizontal surface **410**. The angled portions **360** may have a reflective material layered above the diffusive material. Conversely, the angled portions **360** may have exposed aluminum. Thus, the reflective surfaces of the flexible substrate provide the same effect as the rigid metal reflector plate used in conventional linear LED modules. Additionally, a conductive layer may be arranged over the surface **410** depending on the type of LED utilized for the design.

FIG. **4b** illustrates a cross-section view of an exemplary embodiment of a light emitting apparatus having the flexible substrate of FIG. **4a**. As illustrated in more detail, the bent portions **360** of the flexible substrate are bent up at bending points **470**. The angled portions **360** are bent at a particular angle **480**. The particular angle **480** may be a predetermined angle based on specifications of a lighting module that will use the flexible substrate. Preferably, the angle **480** may be between  $30^\circ$  and  $60^\circ$ , but other angle may be used depending on the particular application. Thus, the exemplary design illustrated in FIG. **4b** provides the same effect as conventional linear LED modules, but uses a less costly and less complex design.

In some aspects of the apparatus, the flexible substrate **340** may be mounted on an inexpensive linear plastic object. Additionally, the angle may be adjusted to suit different troffer designs, while still providing the requisite focusing effect on the emitted light.

FIG. **5** illustrates a cross-section view of a troffer device **500** of an exemplary embodiment of the light emitting device having a flexible substrate. The illustrated troffer device **500** may be suitable for use as an internal lighting device, such as a ceiling light. The troffer device **500** includes a housing **530**. In some aspects of the light emitting device, the housing **540** may be a housing that is typically used for fluorescent lighting. The housing **540** includes a flexible substrate **510** and several LEDs **520**. As shown, the LEDs **520** are arranged on the flexible substrate **510**. The flexible substrate and light distribution pattern emitted from the troffer device **500** will be discussed in greater detail with respect to FIGS. **6** and **7**.

FIG. **6** illustrates a side view of a troffer device **600** of an exemplary embodiment of the light emitting device. The side view illustrated in FIG. **6** may be a side view of the troffer device **500** described with respect to FIG. **5**. As shown, the troffer device **600** includes a housing **630**, a reflective surface **610** of the flexible substrate, a diffusive surface **650** of the flexible substrate, and a bending point **660**. FIG. **6** also illustrates a light distribution pattern **640**.

As shown, the LED **620** is arranged on the diffusive surface **650**. In some aspects of the light emitting device, the diffusive surface **650** covers a portion of the flexible substrate around the LED **620** and between angled portions of the flexible substrate. The angled portion of the flexible substrate may include the reflective surface **610**. As shown, the flexible substrate is bent at bending point **660** to fit the

housing **630**. The flexible substrate may be bent along any point to form various different angles and configurations. Thus, the flexible substrate may be configured to fit a variety of different sized troffer housings.

The troffer device **600** is configured to focus light in a downward direction as is shown by light distribution pattern **640**. Specifically, the reflective portions **610** of the flexible substrate are angled such that light emitted from the LED **620** may reflect off of the reflective surface **610** to enhance the light distribution effects of the troffer device **600** by focusing the light downward. The light may be focused toward a diffusive lens positioned at the bottom of the troffer device, which produces a more uniform light distribution. Additionally, some of the light emitted from LED **620** may be diffused by the diffusive surface **650** further enhancing the lighting efficacy. The combination of the diffusive surface **650** and reflective surfaces **610** of the flexible substrate provides a downward focused light distribution pattern **640** similar to the light distribution pattern of conventional linear LED modules that use a substrate mounted on a reflector.

FIG. **7** further illustrates a cross-section view of a troffer device **700** that provides light distribution pattern **750**. FIG. **7** illustrates similar components to those described with respect to FIGS. **5** and **6**. For instance, troffer device **700** includes a housing **670** similar to housing **530**. The housing includes a flexible substrate **710** similar to the flexible substrate **510**. The flexible substrate **510** includes a diffusive portion **720**, which is similar to the diffusive portion **650**. Additionally, the housing includes several LEDs **730**, similar to the LED **620**, arranged on the diffusive portion of the flexible substrate.

As shown, LEDs **730** may emit light **740**, which is reflective off of the angled portions of the flexible substrate as described with respect to FIG. **6**. Additionally, some of the emitted light **760** may be diffused by the diffusive portion **720** of the flexible substrate. The combination of the diffused and reflected light produces a focused light distribution pattern which may be diffused by a lens to produce the more desirable uniform lighting pattern **750**. Thus, the flexible substrate arrangement a suitable replacement for the rigid reflector and substrate of conventional linear LED lighting systems because it produces the same lighting effect while using a simpler design.

The various aspects of this disclosure are provided to enable one of ordinary skill in the art to practice the present invention. Various modifications to exemplary embodiments presented throughout this disclosure will be readily apparent to those skilled in the art, and the concepts disclosed herein may be extended to other devices. Thus, the claims are not intended to be limited to the various aspects of this disclosure, but are to be accorded the full scope consistent with the language of the claims. All structural and functional equivalents to the various components of the exemplary embodiments described throughout this disclosure that are known or later come to be known to those of ordinary skill in the art are expressly incorporated herein by reference and are intended to be encompassed by the claims. Moreover, nothing disclosed herein is intended to be dedicated to the public regardless of whether such disclosure is explicitly recited in the claims. No claim element is to be construed under the provisions of 35 U.S.C. §112(f) unless the element is expressly recited using the phrase "means for" or, in the case of a method claim, the element is recited using the phrase "step for."

What is claimed is:

1. A light emitting apparatus comprising:  
a substrate having at least one angled portion;

at least one light emitting device arranged on the substrate; and  
 a plurality of conductors arranged on the substrate and coupled to the at least one light emitting device, wherein the substrate comprises a diffusive surface disposed around at least a portion of the at least one light emitting device, and wherein the diffusive surface comprises a white portion.

2. The light emitting apparatus of claim 1, wherein the substrate comprises a flexible substrate.

3. The light emitting apparatus of claim 2, wherein the flexible substrate is manufactured using a reel-to-reel process.

4. A light emitting apparatus comprising:  
 a substrate having at least one angled portion;  
 at least one light emitting device arranged on the substrate; and  
 a plurality of conductors arranged on the substrate and coupled to the at least one light emitting device, wherein the substrate comprises a diffusive surface disposed around at least a portion of the at least one light emitting device, and wherein the diffusive surface comprises a white solder mask.

5. The light emitting apparatus of claim 1, wherein the substrate comprises a plurality of layers has at least one dielectric disposed therebetween, and the plurality of layers comprise at least one of aluminum (AL) and copper (CU).

6. The light emitting apparatus of claim 1, wherein the at least one light emitting device comprises a flip-chip.

7. The light emitting apparatus of claim 1, further comprising an encapsulant disposed on a surface of the at least one light emitting device.

8. A light emitting apparatus comprising:  
 a substrate having at least one angled portion;  
 at least one light emitting device arranged on the substrate; and  
 a plurality of conductors arranged on the substrate and coupled to the at least one light emitting device, wherein the substrate comprises a diffusive surface disposed around at least a portion of the at least one light emitting device, and wherein the at least one angled portion comprises exposed aluminum (AL).

9. The light emitting apparatus of claim 1, wherein an angle of the at least one angled portion is in a range of 30-60 degrees.

10. The light emitting apparatus of claim 1, wherein the substrate is part of a troffer.

11. The light emitting apparatus of claim 10, further comprising a diffusive lens positioned at a bottom of the troffer.

12. A troffer device comprising:  
 a housing;  
 a substrate coupled to the housing, the substrate comprising a reflective surface and at least one angled portion;  
 at least one light emitting device arranged on the substrate; and  
 a plurality of conductors arranged on the substrate and coupled to the at least one light emitting device, wherein the substrate comprises a diffusive surface disposed around at least a portion of the at least one light emitting device, and wherein the diffusive surface comprises a white portion.

13. The troffer device of claim 12, wherein the substrate comprises a flexible substrate.

14. A troffer device comprising:  
 a housing;  
 a substrate coupled to the housing, the substrate comprising a reflective surface and at least one angled portion;  
 at least one light emitting device arranged on the substrate; and  
 a plurality of conductors arranged on the substrate and coupled to the at least one light emitting device, wherein the substrate comprises a diffusive surface disposed around at least a portion of the at least one light emitting device, and wherein the diffusive surface comprises a white solder mask.

15. The troffer device of claim 12, wherein the substrate comprises a plurality of layers having at least one dielectric disposed therebetween, and wherein the plurality of layers comprise at least one of aluminum (AL) and copper (CU).

16. The troffer device of claim 12, further comprising an encapsulant disposed on a surface of the at least one light emitting device.

17. The troffer device of claim 12, wherein an angle of the at least one angled portion is in a range of 30-60 degrees.

18. The troffer device of claim 12, further comprising a diffusive lens positioned at a bottom of the housing.