



US009276177B2

(12) **United States Patent**
Tong et al.

(10) **Patent No.:** **US 9,276,177 B2**
(45) **Date of Patent:** **Mar. 1, 2016**

(54) **LED LENS DESIGN WITH MORE UNIFORM COLOR-OVER-ANGLE EMISSION**

(71) Applicant: **Bridgelux, Inc.**, Livermore, CA (US)

(72) Inventors: **Tao Tong**, Fremont, CA (US); **Wenhui Zhang**, Pleasanton, CA (US); **R. Scott West**, Pleasanton, CA (US)

(73) Assignee: **Bridgelux, Inc.**, Livermore, CA (US)

(*) Notice: Subject to any disclaimer, the term of this patent is extended or adjusted under 35 U.S.C. 154(b) by 0 days.

(21) Appl. No.: **14/717,977**

(22) Filed: **May 20, 2015**

(65) **Prior Publication Data**

US 2015/0255687 A1 Sep. 10, 2015

Related U.S. Application Data

(63) Continuation of application No. 13/866,562, filed on Apr. 19, 2013, now Pat. No. 9,065,024.

(60) Provisional application No. 61/641,219, filed on May 1, 2012.

(51) **Int. Cl.**

H01L 33/50 (2010.01)
H01L 25/075 (2006.01)
H01L 33/54 (2010.01)
H01L 33/60 (2010.01)

(52) **U.S. Cl.**

CPC **H01L 33/50** (2013.01); **H01L 25/0753** (2013.01); **H01L 33/505** (2013.01); **H01L 33/507** (2013.01); **H01L 33/54** (2013.01); **H01L 33/60** (2013.01); **H01L 2924/0002** (2013.01)

(58) **Field of Classification Search**
CPC H01L 33/54; H01L 33/56; H01L 33/60; H01L 33/505; H01L 33/502
See application file for complete search history.

(56) **References Cited**

U.S. PATENT DOCUMENTS

7,312,560 B2 *	12/2007	Ouderkirk	H01L 33/46 313/113
7,520,641 B2	4/2009	Minano et al.	362/297
7,670,031 B2	3/2010	Ogawa et al.	362/311.02
8,253,154 B2	8/2012	Jung et al.	257/98
8,475,013 B2	7/2013	Takahashi et al.	362/363
2011/0085352 A1	4/2011	Ito et al.	362/617
2013/0270587 A1 *	10/2013	Ouderkirk	H01L 33/60 257/89

* cited by examiner

Primary Examiner — John C Ingham

(74) *Attorney, Agent, or Firm* — Imperium Patent Works; Darien K. Wallace

(57) **ABSTRACT**

An LED device with improved angular color performance has a silicone lens shaped as a portion of a sphere. The lens is molded over an array of LED dies disposed on the upper surface of a substrate. Phosphor particles are disbursed throughout the material used to mold the lens. The distance between farthest-apart edges of the LED dies is more than half of the length that the lens extends over the surface of the substrate. The distance from the top of the lens dome to the surface of the substrate is between 57% and 73% of the radius of the sphere. Shaping the lens as the top two thirds of a hemisphere reduces the non-uniformity in the emitted color such that neither of the CIE color coordinates x or y of the color changes more than 0.004 over all emission angles relative to the surface of the substrate.

18 Claims, 9 Drawing Sheets

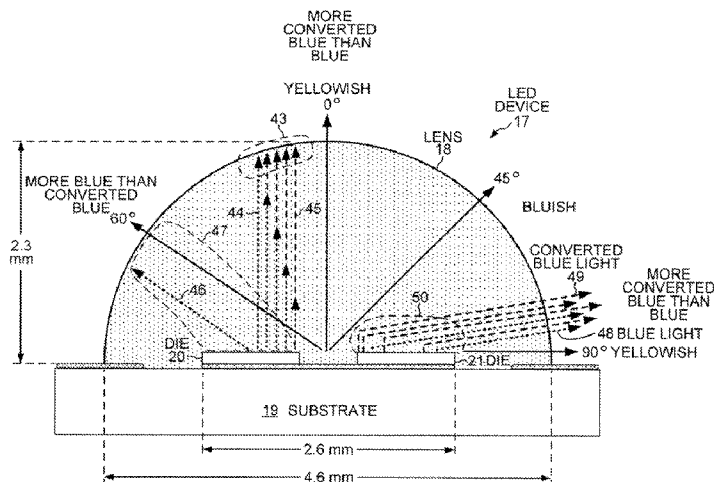

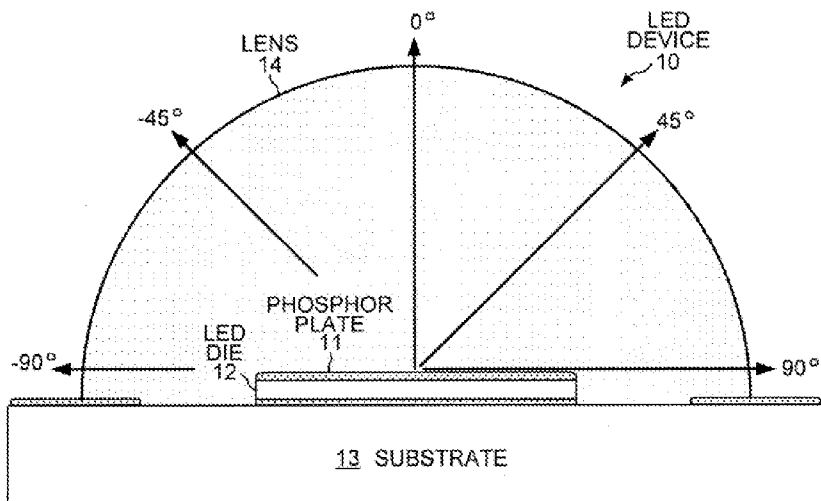

FIG. 1
(PRIOR ART)

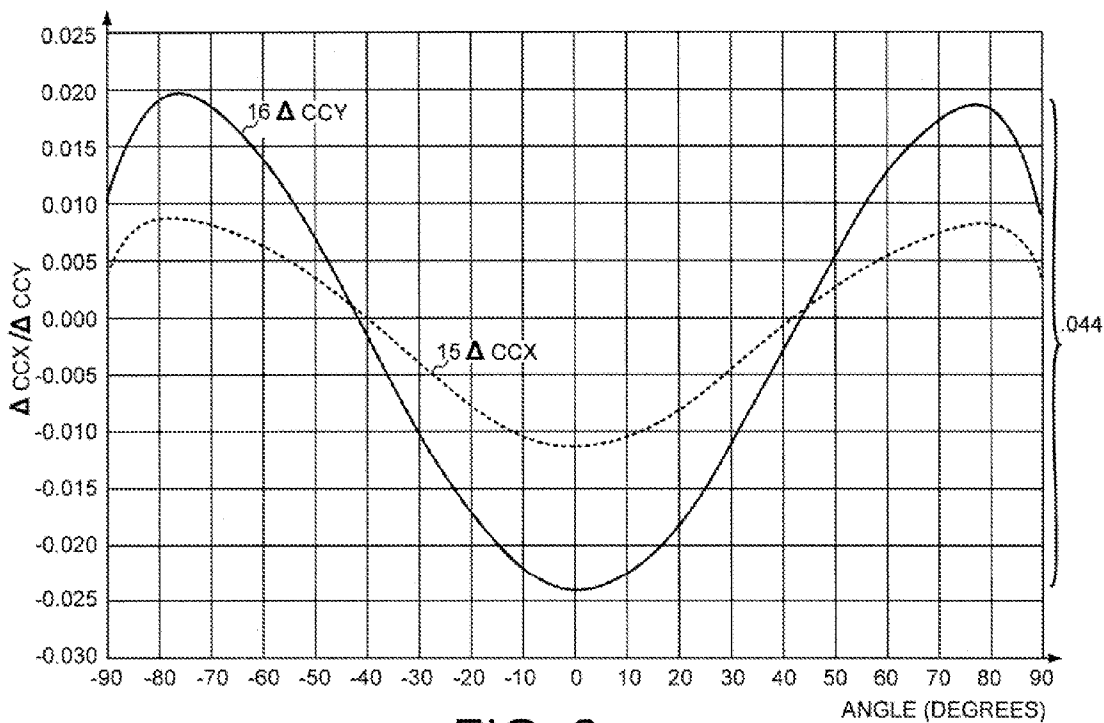

FIG. 2
(PRIOR ART)

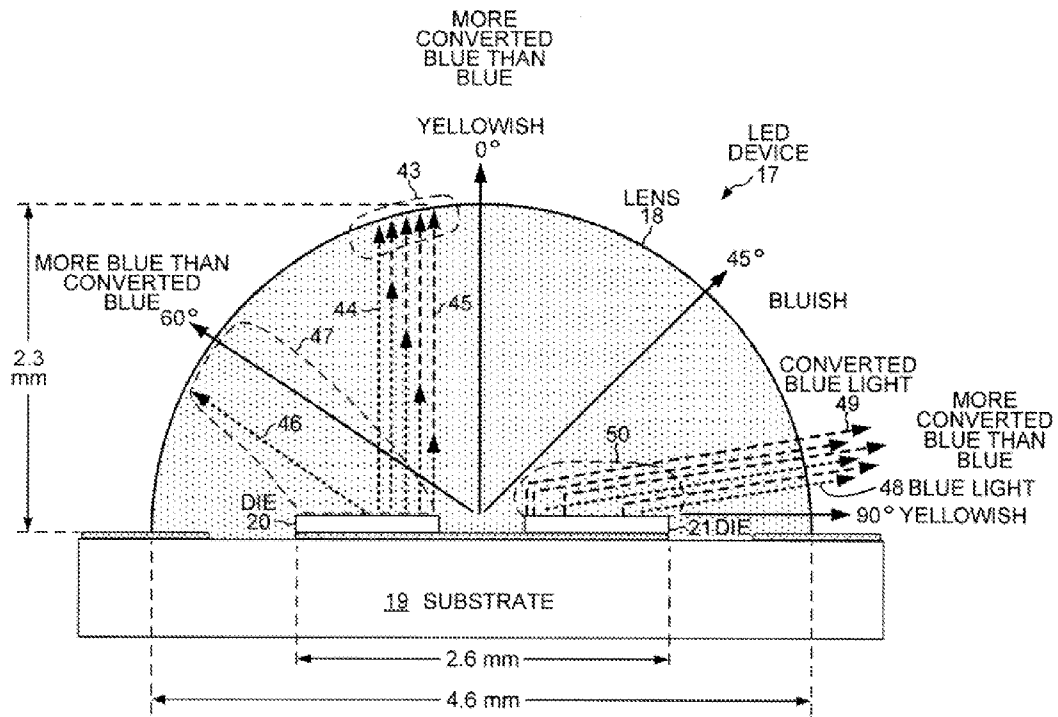

FIG. 3

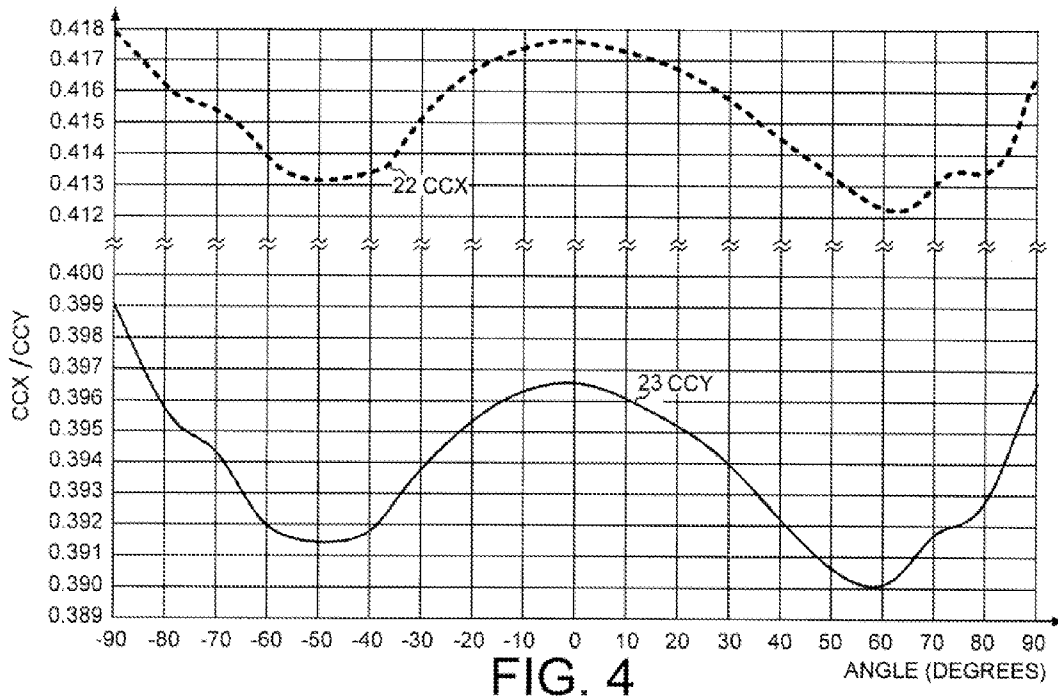

FIG. 4

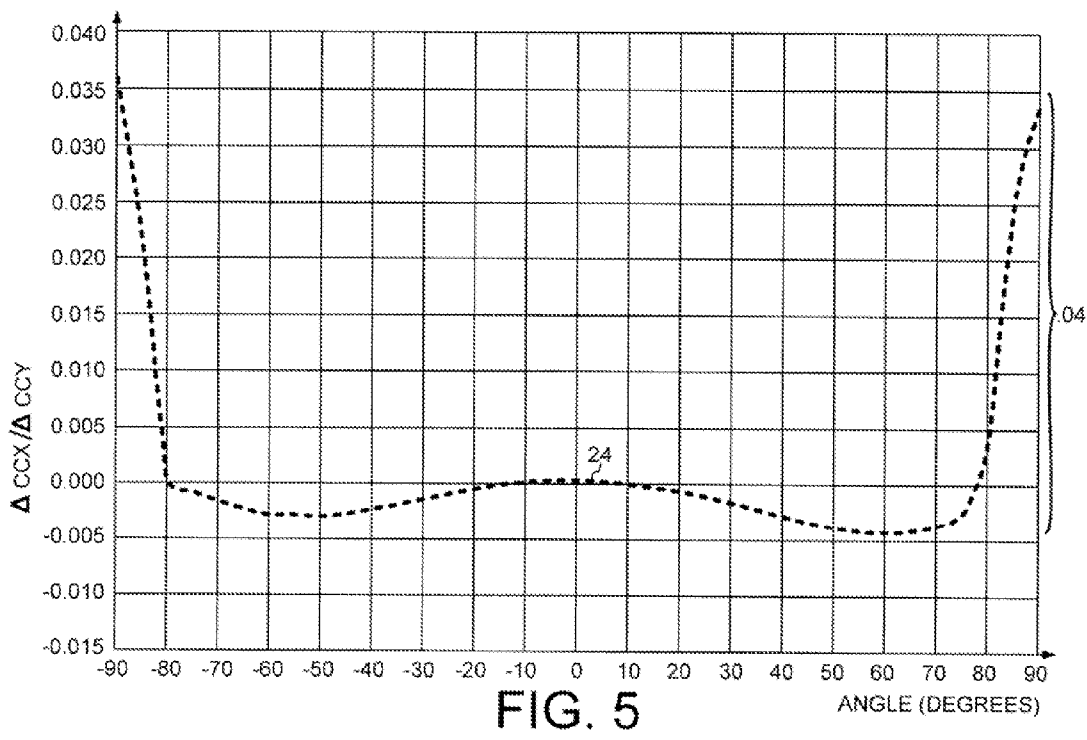

FIG. 5

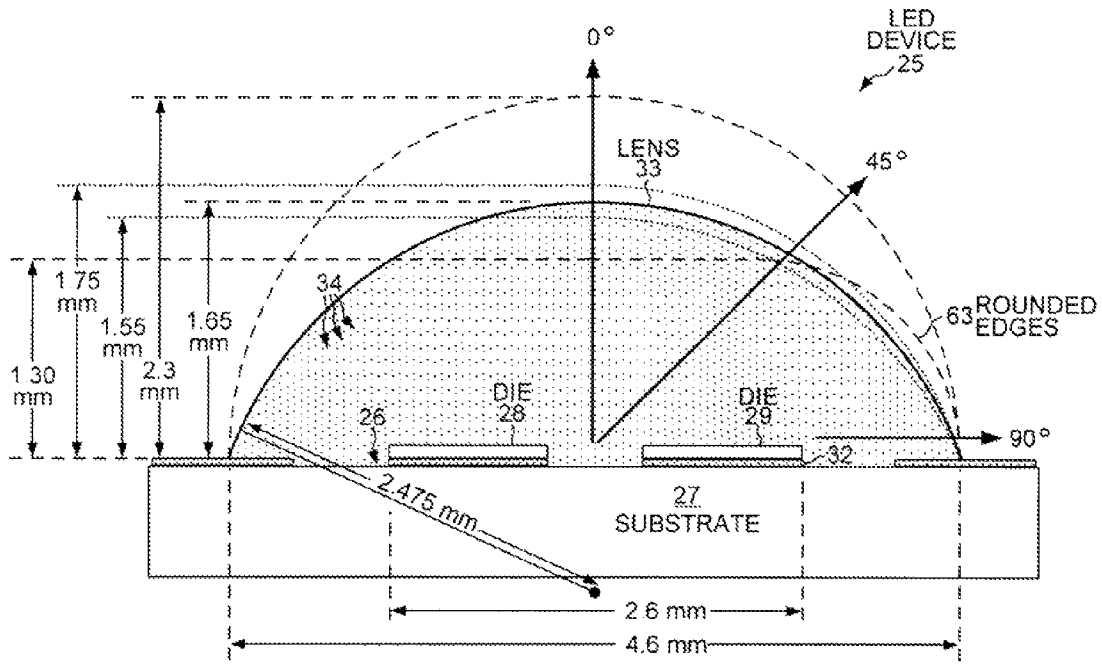

FIG. 6

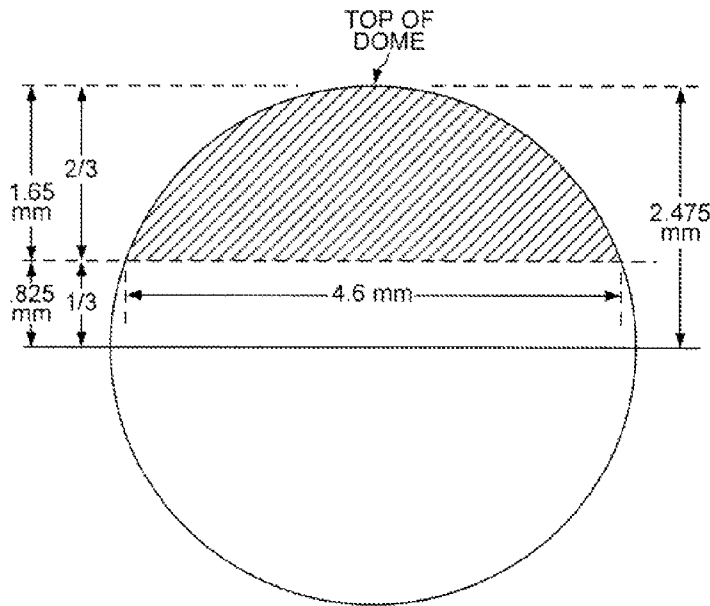

FIG. 9

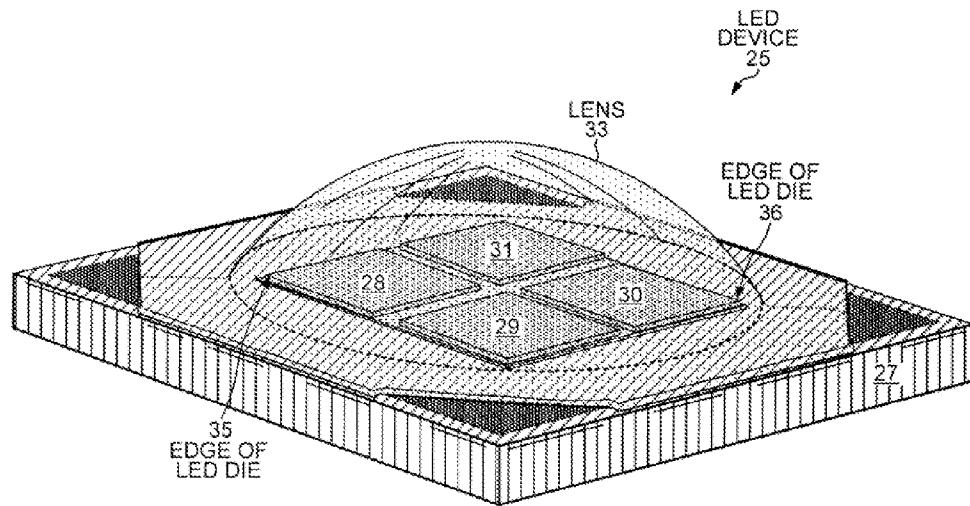

FIG. 7

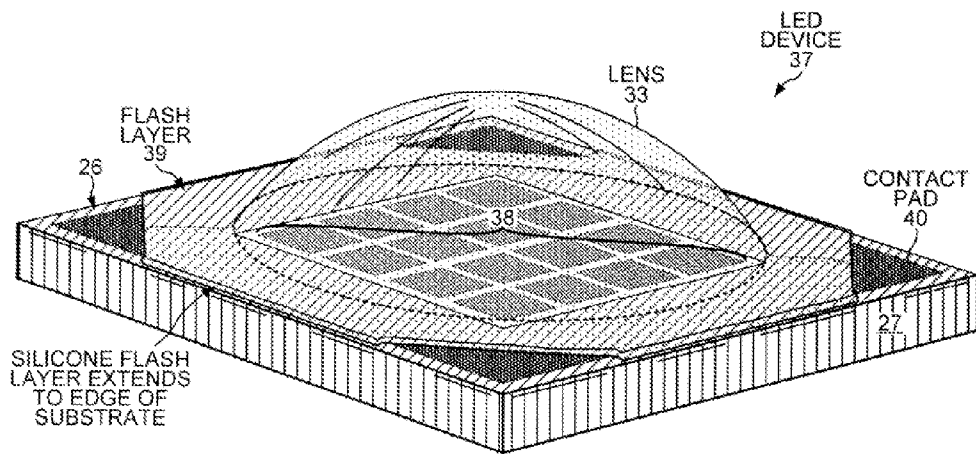

FIG. 8

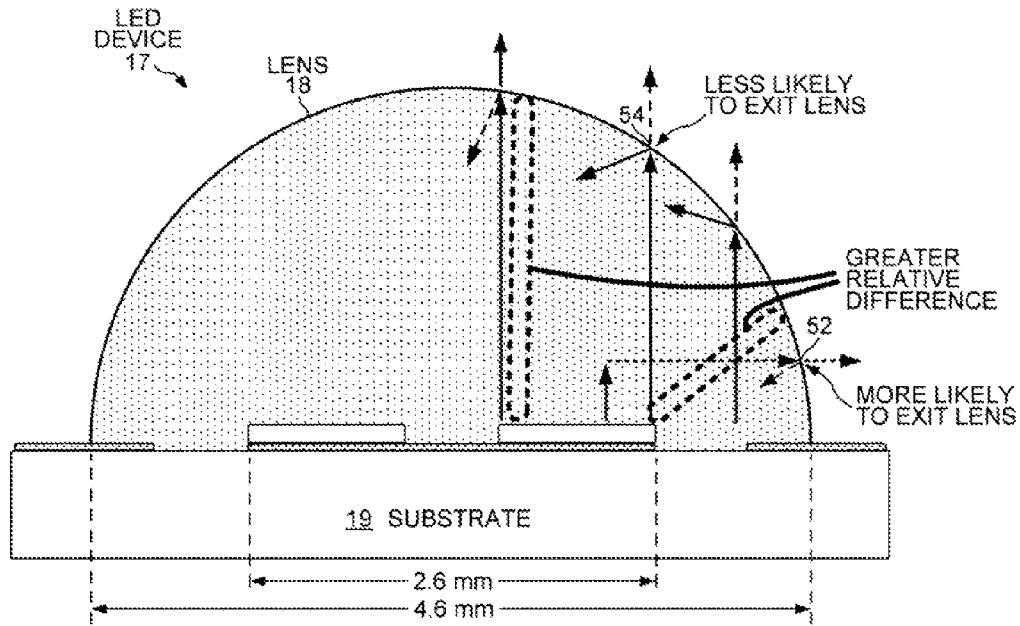

FIG. 10

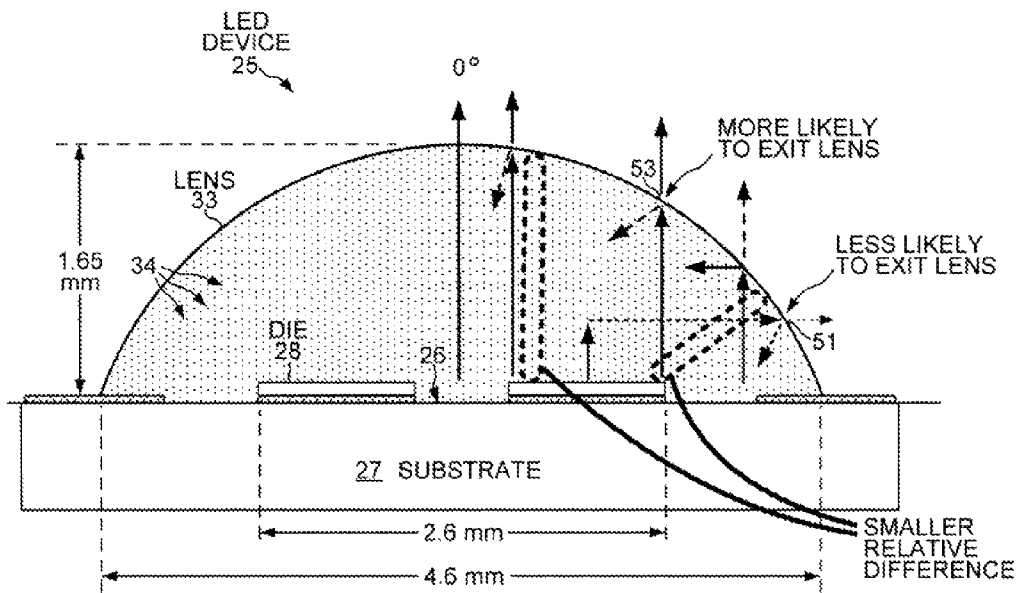

FIG. 11

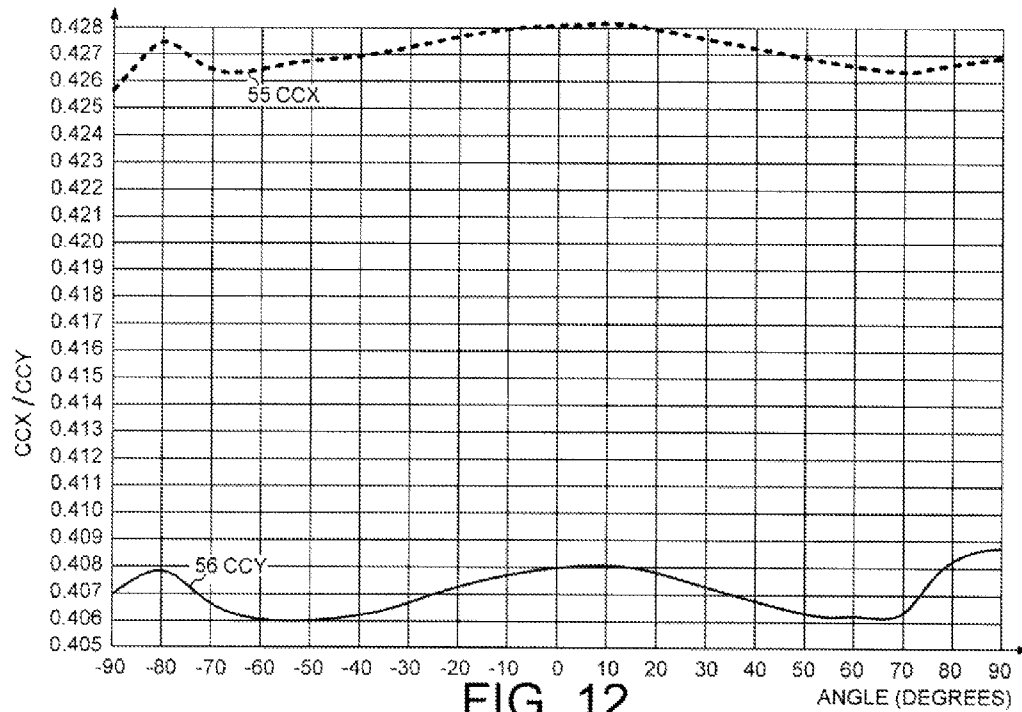

FIG. 12

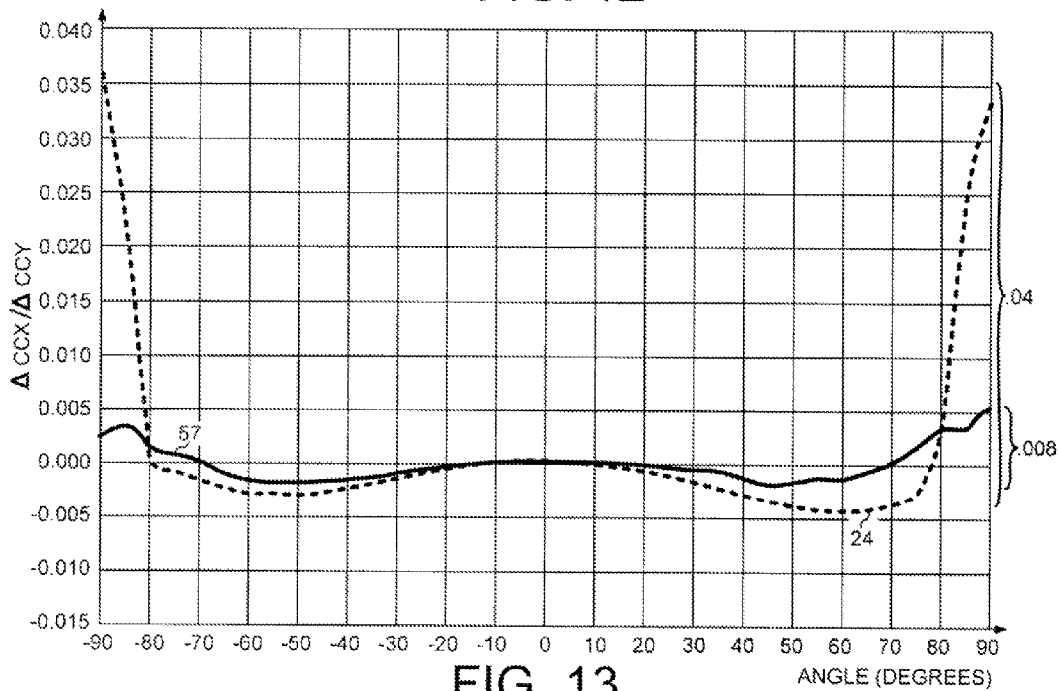

FIG. 13

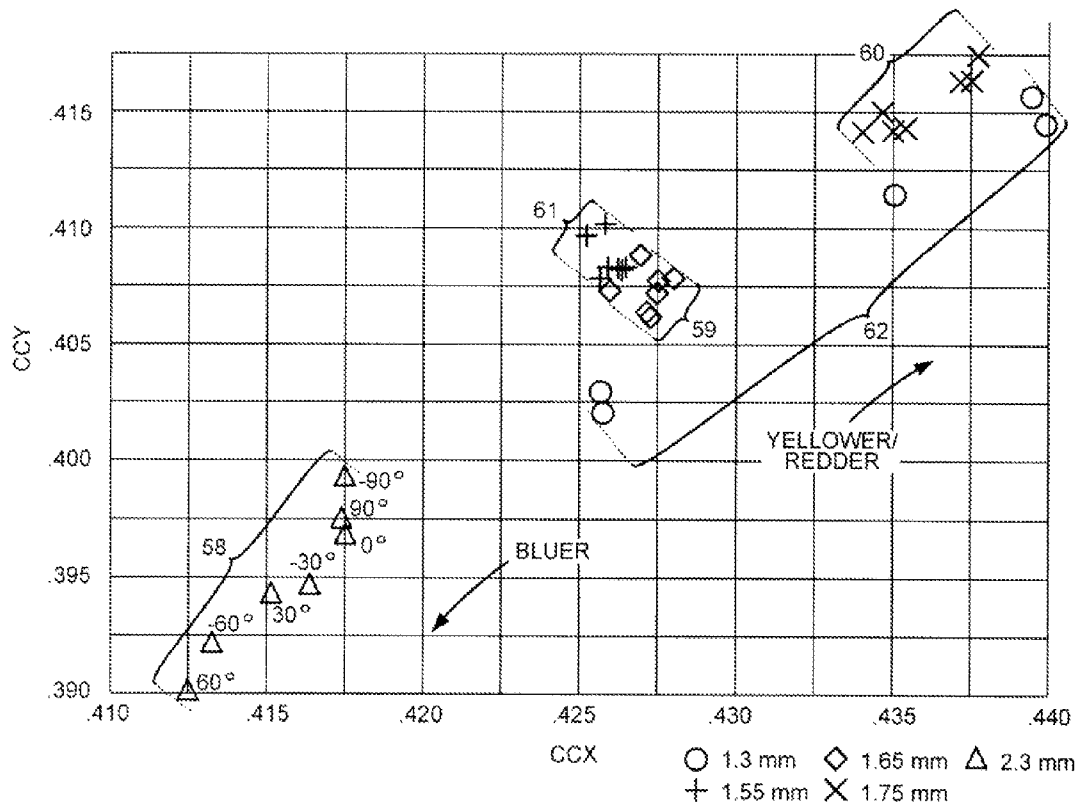

FIG. 14

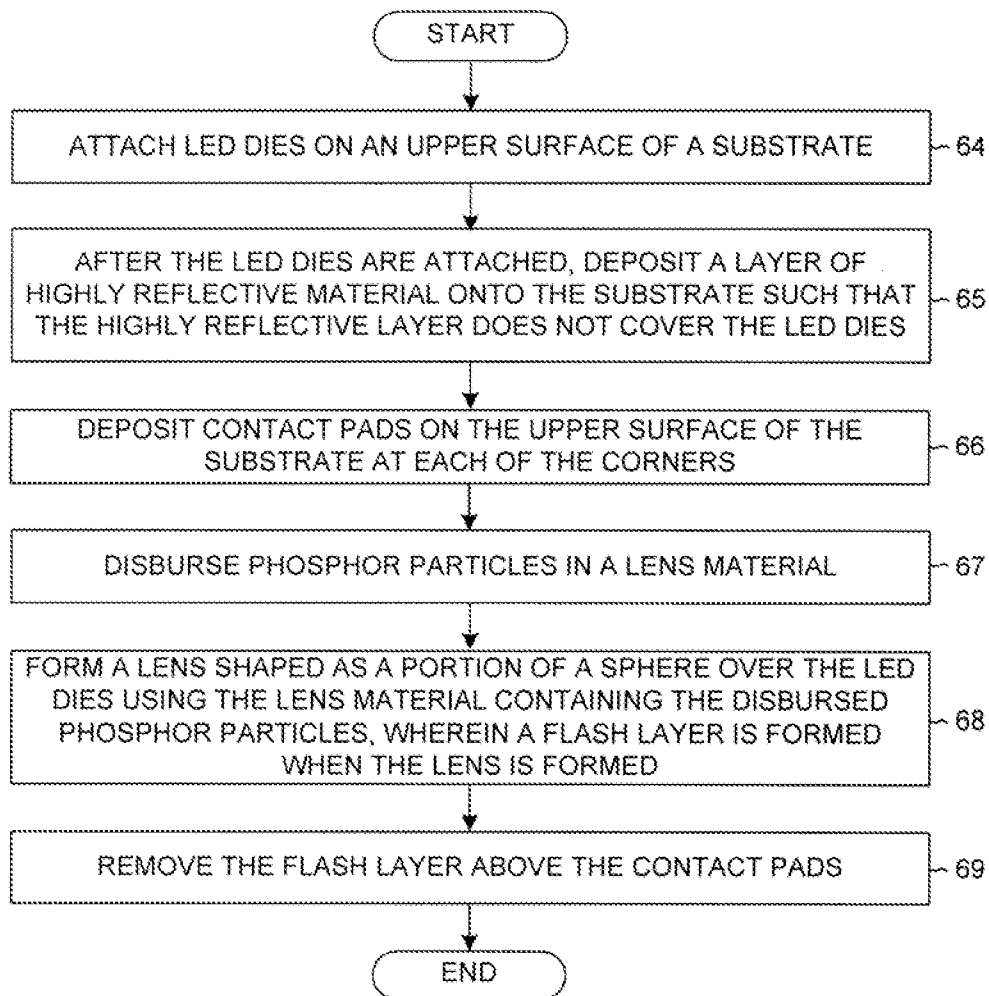

FIG. 15

LED LENS DESIGN WITH MORE UNIFORM COLOR-OVER-ANGLE EMISSION

CROSS REFERENCE TO RELATED APPLICATIONS

This application is a continuation of, and claims priority under 35 U.S.C. §120 from, nonprovisional U.S. patent application Ser. No. 13/866,562 entitled “LED Lens Design with More Uniform Color-Over-Angle Emission,” filed on Apr. 19, 2013, the subject matter of which is incorporated herein by reference. Application Ser. No. 13/866,562, in turn, claims priority under 35 U.S.C. §119 from U.S. Provisional Application No. 61/641,219, entitled “LED Lens Design with More Uniform Color-Over-Angle Emission,” filed on May 1, 2012, the subject matter of which is incorporated herein by reference.

TECHNICAL FIELD

The present invention relates generally to light-emitting diodes and, more specifically, to a lens design that causes the color of the emitted light to be more uniform over the entire range of angles from which the light is emitted.

BACKGROUND INFORMATION

A light emitting diode (LED) is a solid state device that converts electrical energy to light. Light is emitted from active layers of semiconductor material sandwiched between oppositely doped layers when a voltage is applied across the doped layers. The active layers typically include InGaN materials that emit blue light. In order to produce white light, wavelength converting materials commonly known as phosphors are used to convert part of the blue light emitted by the LED into light of longer wavelengths, such as yellow and red, so as to generate a combination of light having the desired spectral characteristics. Examples of phosphors are yttrium aluminum garnet ($Y_3Al_5O_{12}$ or YAG) and terbium aluminum garnet ($Tb_3Al_5O_{12}$ or TAG). The combination of blue and yellow light appears to the human eye as “cool white,” which has a color temperature in the range of 5000-8000 degrees Kelvin, corresponding to daylight. By adding red to the blue and yellow light, “warm white” light can be generated with a color temperature in the range of 2700-3500 degrees Kelvin, which is used for indoor lighting.

FIG. 1 (prior art) shows a conventional LED device **10** in which the phosphor **11** is deposited as a layer over an LED die **12** disposed on the upper surface of a substrate **13**. A silicone lens **14** is molded over LED die **12** and phosphor plate **11**. Phosphor plate **11** covers only the top surface of LED die **12** and does not cover the sides. The light that is emitted from lens **14** contains different amounts of blue and yellow at different angles. For example, the light that is emitted orthogonally from the top surface of LED die **12** and out through the top of the domed lens **14** (at zero degrees) is much bluer than the light that is emitted in a ring at about seventy-five degrees from orthogonal.

FIG. 2 (prior art) is a graph of the angular color performance of LED device **10** of FIG. 1. The graph shows how the color of the light emitted from lens **14** changes over the angle of the emitted light. The colors are defined by the color coordinates x and y of the CIE XYZ color space created by the International Commission on Illumination (CIE). The dashed line **15** indicates the change in the color coordinate x (Δccx) over the emission angles -90° through 0° to 90° , as those angles are shown in FIG. 1. The solid line **16** indicates the

change in the color coordinate y (Δccy) over the same range of emission angles. Solid line **16** shows that the value of the color coordinate y increases by as much as 0.044 over the range of emission angles from 0° to 75° , while the color coordinate x also increases over the same range. Thus, LED device **10** produces a bluish spot centered at 0° and a yellowish ring at about 75° . Customers of LED device **10** find the bluish spot and yellowish ring to be undesirable and would prefer a uniform white light to be emitted at all angles.

FIG. 3 shows an LED device **17** that exhibits a somewhat improved angular color performance compared to LED device **10** of FIG. 1. The phosphor in LED device **17** is disbursed throughout the silicone that forms an hemispherical lens **18**. The silicone lens **18** is molded onto the upper surface of a substrate **19** and over an array of LED dies that includes die **20** and die **21**. But LED device **17** also exhibits some non-uniformity in its color-over-angle light emission characteristics.

FIG. 4 is a graph showing the angular color performance of LED device **17** of FIG. 3. The graph shows how the color of the light emitted from lens **14** changes over the angle of the emitted light. The colors are indicated with the color coordinates x and y of the CIE-1931 XYZ color space. The dashed line **22** indicates how the color coordinate x (ccx) changes over the emission angles -90° through 0° to 90° , as those angles are shown in FIG. 3. The solid line **23** indicates the how the color coordinate y (ccy) changes over the emission angles -90° through 0° to 90° . FIG. 4 shows that LED device **17** produces a bluish ring at about $\pm 55^\circ$ between a yellowish spot at 0° and a yellowish ring towards $\pm 90^\circ$. The color performance indicated in FIG. 4 applies to LED dies and phosphors that produce warm white light corresponding to about 3000° K. Where less phosphor is used to produce cool white light, such as corresponding to 5600° K, the variation in the color over the range of emission angles is even larger.

FIG. 5 shows the change in values of the color coordinates x and y indicated in FIG. 4. The change in the values of the color coordinate x over the range of emission angles is about the same as the change in the values of the color coordinate y , so dashed line **24** represents the change in each of the color coordinates x and y . The values of the color coordinates x and y increase by as much as 0.04 from about 60° to 90° and from about -50° to -90° . Although the change in color over emission angle for LED device **17** is somewhat less than for LED device **10**, the bluish ring at about $\pm 55^\circ$ from LED device **17** is more noticeable than the bluish spot at 0° from LED device **10**. The bluish spot at 0° is less perceptible because the color is constantly becoming more bluish as the emission angle decreases for LED device **10**, whereas the color emitted by LED device **17** becomes more bluish towards the ring at about $\pm 55^\circ$ and then rapidly becomes more yellowish. The human eye is more sensitive to the change toward more blue and then less blue than to a constant change in one color direction. Customers of LED device **17** find the bluish ring to be undesirable.

An LED device is sought that emits light with a more uniform color distribution over the entire range of emission angles so that colored spots and rings are less perceptible.

SUMMARY

An LED device that exhibits improved angular color performance has a novel lens shaped as a portion of a sphere. The lens is molded over an array of LED dies disposed on the upper surface of a substrate. Phosphor particles are disbursed throughout the silicone that is used to mold the lens. The distance between farthest apart edges of the LED dies is more

than half of the bottom chord length that the lens extends over the upper surface of the substrate. The distance from the top of the dome of the lens to the upper surface of the substrate is between 57% and 73% of the radius of the sphere of which the lens shape is a portion. The lens shaped as the top two thirds of a hemisphere is a means for reducing the non-uniformity in the color emitted by the LED device over all emission angles relative to the upper surface of the substrate such that neither of the CIE color coordinates x or y of the color changes more than 0.004 over all emission angles relative to the surface of the substrate. For example, light is emitted at the angles from -90° through 0° to 90° .

A layer of highly reflective material is disposed over the upper surface of the substrate and renders the upper surface of the substrate more reflective than the top surfaces of the LED dies. The highly reflective layer does not extend under the LED dies and does not extend over the LED dies, but rather contacts the edges of the LED dies. Lens material is compression molded to form the dome of the lens together with a flash layer over the upper surface of the substrate. Contact pads are disposed on the upper surface of the substrate laterally outside of the dome. The dome and the flash layer are disposed over substantially all of the upper surface of the substrate except for over the contact pads.

A method involves forming a lens over LED dies using a lens material containing dispersed phosphor particles. The LED dies are attached to the upper surface of a substrate. The lens has a dome and is shaped as a portion of a sphere. The bottom chord length of the lens is less than twice the surface emitter length between farthest apart edges of the LED dies. The height of the dome above the upper surface of the substrate is between 57% and 73% of the radius of the sphere of which the lens shape is a portion.

An LED device includes LED dies, phosphor particles and a means for reducing the non-uniformity in the color of the light emitted by the LED device over all of the emission angles. The LED dies are disposed on an upper surface of a substrate. The surface emitter length is the maximum distance between farthest apart edges of the LED dies. The phosphor particles are dispersed throughout a material that is molded over the LED dies on the upper surface of the substrate. The LED dies emit bluish light, and the phosphor particles convert some of the bluish light to yellowish light. The emitted bluish light combined with the emitted yellowish light together exhibit a color at each angle relative to the upper surface of the substrate. The means reduces the non-uniformity in the color of the emitted light such that each of the CIE color coordinates x and y of the emitted color does not change more than 0.004 over all angles relative to the upper surface. The surface emitter length is more than twice the maximum length that the means extends over the upper surface of the substrate.

Further details and embodiments and techniques are described in the detailed description below. This summary does not purport to define the invention. The invention is defined by the claims.

BRIEF DESCRIPTION OF THE DRAWINGS

The accompanying drawings, where like numerals indicate like components, illustrate embodiments of the invention.

FIG. 1 (prior art) is a cross-sectional view of a conventional LED device in which phosphor is deposited as a layer over an LED die on the upper surface of a substrate.

FIG. 2 (prior art) is a graph of the change in the color coordinates x and y over the emission angles -90° through 0° to 90° for the light emitted by the LED device of FIG. 1.

FIG. 3 is a cross-sectional view of an LED device that exhibits a somewhat improved angular color performance compared to the LED device of FIG. 1.

FIG. 4 is a graph of the color coordinates x and y over the emission angles -90° through 0° to 90° for the light emitted by the LED device of FIG. 3.

FIG. 5 is a graph of the change in the color coordinates x and y over the emission angles -90° through 0° to 90° for the light emitted by the LED device of FIG. 3.

FIG. 6 is a cross-sectional view of a novel LED device having a lens that is a portion of a sphere and that emits light with a more uniform color over the entire range of emission angles.

FIG. 7 is a perspective view of the LED device of FIG. 6 showing two-by-two array of LED dies.

FIG. 8 is a perspective view of an LED device with a four-by-four array of LED dies and a lens that is a portion of a sphere.

FIG. 9 shows a cross section of the top two-thirds by height of the top half of a sphere with dimensions corresponding to the lens of the LED device of FIG. 6.

FIG. 10 is a cross-sectional view of the LED device of FIG. 3.

FIG. 11 is a cross-sectional view of the LED device of FIG. 6. FIGS. 10-11 compare the internal reflectance of light emitted at various angles within the lenses.

FIG. 12 is a graph of the color coordinates x and y over the emission angles -90° through 0° to 90° for the light emitted by the LED device of FIG. 6.

FIG. 13 is a graph of the change in the color coordinates x and y over the emission angles -90° through 0° to 90° for the light emitted by the LED device of FIG. 6.

FIG. 14 is a plot of the color coordinates x and y showing the distribution of colors emitted at various angles by different lens designs, including the lenses of the LED devices of FIGS. 3 and 6.

FIG. 15 is a flowchart of steps of a method for forming a lens for LED dies that results in greater uniformity of the color of the emitted light.

DETAILED DESCRIPTION

Reference will now be made in detail to some embodiments of the invention, examples of which are illustrated in the accompanying drawings.

FIG. 6 is a cross-sectional view of a novel LED device 25 that emits light with a more uniform color over the entire range of emission angles. LED device 25 includes an array of light emitting diode (LED) dies disposed on the upper surface 26 of a substrate 27. For example, LED device 25 includes a two-by-two array of LED dies, including LED dies 28-31. Thermal interface materials 32 are disposed between the LED dies and substrate 27. For example, the thermal interface materials 32 may include a silver-filled epoxy deposited over a layer of Cu-Ni-Au alloy or Cu-Ni-Ag alloy. A lens material is then overmolded over the LED dies 28-31 and forms the shape of a lens 33. For example, the lens material is a clear resin encapsulant, such as silicone or epoxy. The lens material is disposed on the upper surface 26 of substrate 27 and over the LED dies 28-31.

Phosphor particles 34 are dispersed evenly throughout the lens material. Bluish light is emitted from the top surfaces of the LED dies 28-31. A portion of the bluish light strikes the particles of phosphor 34 and is converted into yellowish light. Thus, the LED dies act as surface emitters, whereas the phosphor particles 34 within lens 33 act as a volume emitter. A surface emitter length extends from an edge of one of the LED

dies to a farthest edge of another of the LED dies. In the orientation of the LED dies **28-31** shown in FIG. **6**, the surface emitter length extends at least from one edge of LED die **28** to the farthest edge of LED die **29**. In the orientation of FIG. **6**, the surface emitter length is 2.6 millimeters.

FIG. **7** is a perspective view of LED device **25** that shows the two-by-two array of LED dies **28-31**. In the diagonal orientation, the surface emitter length extends from the farthest point **35** on one edge of LED die **28** to the farthest point on the distal edge of LED die **30**. In the orientation of FIG. **7**, the surface emitter length is 3.68 millimeters. FIG. **8** shows an LED device **37** in which lens **33** is molded over a four-by-four array of LED dies. The surface emitter length **38** is the maximum distance between the farthest two edges of the sixteen LED dies. The surface emitter length in FIG. **8** is also 3.68 millimeters. FIG. **8** also shows the flash layer **39** that results when lens **33** is formed using compression molding. The lens material is compression molded to form the domed lens **33** together with flash layer **39** that covers upper surface **26** of substrate **27**. After the molding step, flash layer **39** is removed from above the contact pads **40** at the corners of substrate **27**. Where flash layer **39** is not removed from above the contacts pads **40**, flash layer **39** extends to the edges of substrate **27**. Flash layer **39** is only about fifty microns thick.

The lens material is shaped as a portion of a sphere. Lens **33** is the top two-thirds of a hemisphere by height. In the embodiment of FIG. **6**, the dome height is 1.65 mm and extends from the top of the dome to the upper surface **26** of substrate **27**. FIG. **9** illustrates a cross section of the top two-thirds by height of the top half of a sphere with a radius of 2.475 mm. The radius of the surface of lens **33** in FIG. **6** is 2.475 mm. Thus, the dome height is between 57% and 73% of the radius. The bottom chord length of lens **33** over the upper surface **26** of substrate **27** is the maximum length that the lens material extends over the upper surface **26**. In the embodiment of FIG. **6**, the bottom chord length is 4.6 mm and is, therefore, less than twice the surface emitter length.

LED device **25** exhibits a much smaller variation than does LED device **17** in the color of the light emitted over the range of emission angles. The light emitted by LED device **25** at angles approaching $\pm 90^\circ$ does not include a sharply increasing component of yellow as does the light emitted by LED device **17**. Moreover, LED device **25** has a much less pronounced bluish ring at about $\pm 55^\circ$ and a much fainter yellowish spot at 0° . FIG. **3** illustrates the three factors that cause LED device **17** to produce the yellowish ring towards $\pm 90^\circ$, the bluish ring at about $\pm 55^\circ$, and the yellowish spot at 0° . The effects of these factors are minimized by the design of lens **18** of LED device **25**.

The factors that cause the non-uniformity in color-over-angle performance in LED device **17** are (i) the emission of blue light by a surface emitter combined with (ii) the emission of yellow light by a volumetric emitter (iii) in a configuration in which the blue light travels through different distances of a spherical volumetric emitter because the surface emitter is wider than a point source at the center of the sphere. All light emitted from a point source at the center of a spherical lens strikes the surface of the lens at a normal angle and has the highest probability of exiting the lens as opposed to being reflected internally according to Snell's law. Thus, a conventional lens in an LED device has the form of a hemisphere in order to maximize light extraction. However, the hemispherical shape is retained in LED device **17** despite the fact that the array of LEDs is not a point source. But so long as the diameter of the hemispherical lens is more than twice the surface emitter length across the LEDs, internal reflection is minimal because most of the light emitted from the surface

emitter strikes the surface of the lens at nearly a normal angle and thus exits the lens. Nevertheless, most LED devices exceed this rough rule of thumb and cover more than half of the bottom chord length of the lens with surface emitting LEDs so as to use more of the available space beneath the lens and to generate more light per area occupied by the LED device. The consequence of trying to achieve a higher light output per area of the LED device is not only an increase in internal reflection of the light emitted towards the edges of the surface emitter but also an increase in the non-uniformity of the color of the light emitted over different angles.

The light emitted from LED dies **20-21** in FIG. **3** has an intensity that is proportional to the projected area of the top surface of the dies at the angle from which the emitted light is received. Thus, the blue light emitted from the LED dies has an intensity proportional to the cosine of the angle from which the emitted light is received. The maximum amount of blue light is emitted at a 0° angle, and the amount of blue light diminishes to zero at $\pm 90^\circ$. On the other hand, yellow light is emitted equally in all directions by the phosphor particles that are struck by photons of blue light. However, the amount of phosphor particles in the various paths of the blue light varies and consequently generates differing amounts of yellow light. It is the relative amounts of blue light and yellow light that determine the color of the light that exits lens **18** as opposed to the absolute intensities of the blue and yellow light.

FIG. **3** illustrates that the light **43** exiting lens **18** around 0° at the top of the dome is yellowish because the blue light **44** emitted from the dies has traveled farther through the disbursed phosphor, and more of the blue light **44** has been converted to yellow light **45**. Blue light **46** emitted from the outer edges of the LED dies **20-21**, however, travels through a smaller volume **47** of disbursed phosphor and has a higher probability of exiting lens **18** without being converted to yellow light. Thus, a bluish ring is emitted at about $\pm 55^\circ$. As the angle of the light exiting lens **18** becomes larger than 80° , however, the smaller component **48** of blue light emitted from the surface emitter at high angles becomes significantly over-compensated by the amount of converted blue light **49** emitted by phosphor particles in the volume **50** above each LED die that are struck by the greater amount of blue light emitted normal to the surface emitter. Thus, the light emitted towards $\pm 90^\circ$ is significantly more yellowish.

The design of lens **33** of novel LED device **25** is adapted to devices having a surface emitter of blue light and a volumetric emitter of longer wavelength light in which the surface emitter length is more than half of the bottom chord length of the volumetric emitting lens. LED device **25** sacrifices a higher internal reflection of light emitted towards high angles of the lens in exchange for a higher uniformity in the color of the light exiting the lens over all angles.

FIGS. **10-11** compare the internal reflectance of light emitted at various angles within lens **18** of LED device **17** and within lens **33** of LED device **25**. As shown in FIGS. **10-11**, light emitted from or near the LED dies of LED device **25** that is directed towards a high angle location **51** is less likely to exit lens **33** than is similarly emitted light likely to exit lens **18** at a high angle location **52**. This is because the light strikes the surface of lens **18** at location **52** at a flatter angle than that at which the light strikes lens **33** at location **51**. Conversely, light emitted from the edges of the surface emitter that is directed towards a lower angle location **53** is more likely to exit lens **33** than is similarly emitted light likely to exit lens **18** at a lower angle location **54**. This is because the light strikes the surface of lens **33** at location **53** at a flatter angle than that at which the light strikes lens **18** at location **54**.

Although most of the light exits lens **33** at the flatter angle at location **53**, light extraction is not maximized by further flattening the curve of lens **33** because a small portion of the light is nevertheless reflected even at angles near normal. This small portion of reflected light is more likely to be absorbed by the surfaces of the LED dies as the surface of lens **33** comes closer to the LED dies and the light is less likely to be reflected onto the more reflective upper surface **26** of substrate **27**. Typically, the top surface of the LED dies is about 80% reflective, whereas the upper surface **26** of substrate **27** is more than 90% reflective. By depositing a layer of highly reflective material between the LED dies, the surface above the substrate can be made more than 90% reflective. Thus, the shape of lens **33** is not flattened to significantly less than the top two thirds of a hemisphere in order not to overly increase the absorption of reflected light by the top surfaces of the LED dies and in order not to overly decrease the light extraction at high angles around the edges of the lens. In one embodiment, the layer of highly reflective material disposed over upper surface **26** does not extend under the LED dies **28-31** and does not extend over the LED dies, but rather contacts at least one edge of each of the LED dies.

When the highly reflective material is deposited by jetting, the material flows laterally and wets the side edges of the LED dies. The highly reflective material is deposited with such a thickness that once it has cured and solidified it has a reflectivity of at least ninety percent (for example, 94 percent). In one example, the highly reflective material is the material KER-2010-DAM or material KER-2020 that is commercially available from ShinEtsu Chemical Co. Ltd. of Tokyo, Japan. The highly reflective material may comprise silicone and a titanium dioxide powder, where the titanium dioxide powder is suspended in the silicone. The highly reflective material is made jettable by cutting it with a solvent. In one example, the solvent is an oil-based solvent such as dimethylformamide (DMF) commercially available from ShinEtsu as DMF0.65CS. The highly reflective material after being appropriately cut with the solvent has a viscosity of about 1000 centipois (cP) at room temperature.

FIGS. **10-11** also compare the relative distances that light emitted by the LED dies travels through the phosphor particles before exiting the lenses **18** and **33**. Lens **18** exhibits a greater relative difference between the shortest distance from the surface emitter to the lens surface at around $\pm 60^\circ$ and the longest distance from the surface emitter to the lens surface at 0° . Because there is a smaller relative difference between the shortest distance from the surface emitter to the surface of lens **33** at around $\pm 60^\circ$ and the longest distance at 0° , the relative amounts of exiting blue and yellow light are more similar at $\pm 60^\circ$ and 0° in LED device **25**.

FIG. **12** is a graph showing the angular color performance of LED device **25** of FIG. **6**. The graph shows how the color of the light emitted from lens **33** changes over the angle of the emitted light. The vertical axis indicates the values of both color coordinates x and y in the CIE XYZ color space. The dashed line **55** indicates how the color coordinate x (ccx) changes over the emission angles -90° through 0° to 90° , as those angles are shown in FIG. **6**. The solid line **56** indicates how the color coordinate y (ccy) changes over the emission angles -90° through 0° to 90° . FIG. **12** shows that LED device **25** produces a much fainter bluish ring between angles $\pm 50-65^\circ$ than the bluish ring at about $\pm 55^\circ$ produced by LED device **17**. More importantly, LED device **25** does not emit significantly more yellowish light as the angle of the light exiting lens **33** becomes larger than 80° . Thus, the faint bluish ring between angles $\pm 50-65^\circ$ is hardly perceptible to the human eye because the slight change toward greater blue is

not contrasted by a change toward greater yellow at higher angles. The color performance indicated in FIG. **12** was generated with LED dies and phosphors that produce warm white light corresponding to about 3000° K. The variation in the color over the range of emission angles would be larger if less phosphor were used to produce cool white light, such as light corresponding to 5600° K.

FIG. **13** shows the change in values of the color coordinates x and y indicated in FIG. **12**. The change in the values of the color coordinate x over the range of emission angles is similar to the change in the values of the color coordinate y , so solid line **57** represents the approximate change in each of the color coordinates x and y over the emission angles -90° to 90° . The values of the color coordinates x and y vary by only 0.008 over the entire angular emission range. Dashed line **24** from FIG. **5** is included in FIG. **12** to show the great improvement in color uniformity of LED device **25** compared to LED device **17**. Not only is the color variation of the light emitted by LED device **25** five times smaller than for LED device **17**, but the color variation is also less perceptible to the human eye because the emitted light that becomes slightly more bluish as the emission angle increases from 0° to about $\pm 50^\circ$ does not then revert to becoming significantly more yellowish at emission angles greater than $\pm 80^\circ$ as is the case for LED device **17**.

Flattening the lens of LED device **25** to have the shape of significantly less than the top two thirds of a hemisphere did not significantly increase the color-over-angle uniformity of the emitted light. Thus, the small improvement in the angular color performance of a flatter lens is outweighed by the greater absorption caused by the flatter and shallower lens internally reflecting light directly back to the top surfaces of the LED dies, which absorb more of the internally reflected light than do the other surfaces around the LED dies.

FIG. **14** is a plot of the distribution of colors emitted at various angles from different lens designs. The relative dispersion of the points corresponding to each lens indicates the amount of color-over-angle uniformity. More tightly grouped points indicate greater color uniformity. The triangles **58** plot the ccx and ccy coordinates of the colors emitted from lens **18** of LED device **17** at the seven angles 0° , $\pm 30^\circ$, $\pm 60^\circ$ and $\pm 90^\circ$. Lens **18** has a 2.3 mm dome height over a 4.6 mm bottom chord length. The diamonds **59** plot the ccx and ccy coordinates of the colors emitted from lens **33** of LED device **25** at the same seven angles. Lens **33** has a 1.65 mm dome height over a 4.6 mm bottom chord length. Thus, the radius of the surface of lens **33** is 2.475 mm, and lens **33** has the shape of the top 66% of a hemisphere. The greater spacing between the triangles **58** than between the diamonds **59** indicates that the color-over-angle uniformity of lens **33** is greater than that of lens **18**. For example, the maximum change in the ccx coordinates corresponding to the diamonds **59** over all of the seven angles 0° , $\pm 30^\circ$, $\pm 60^\circ$ and $\pm 90^\circ$ is less than 0.004.

The \times 's **60** plot the ccx and ccy coordinates of the colors emitted from a lens with a 1.75 mm dome height over a 4.6 mm bottom chord length. The surface of such a lens has a radius of 2.386 mm, and the shape of the lens is the top 73.3% of a hemisphere. The spacing between the \times 's **60** compared to the spacing between the diamonds **59** indicates that there is a significant improvement in the angular color performance by lowering the dome height from 1.75 mm to 1.65 mm.

The $+$'s **61** plot the ccx and ccy coordinates of the colors emitted from a lens with a 1.55 mm dome height over a 4.6 mm bottom chord length. The surface of such a lens has a radius of 2.748 mm, and the shape of the lens is the top 56.4% of a hemisphere. The spacing between the $+$'s **61** compared to the spacing between the diamonds **59** indicates that there is

little improvement in the angular color performance by lowering the dome height from 1.65 mm to 1.55 mm. Thus, the small improvement in the angular color performance achieved by reducing the dome height from 1.65 mm to 1.55 mm is outweighed by the greater absorption caused by the flatter lens that is closer to the LED dies and that causes greater internally reflectance of light directly back to the absorptive top surfaces of the LED dies.

FIG. 14 also plots the distribution of colors emitted at various angles from a lens that is not shaped as a portion of a sphere. The circles 62 plot the ccx and ccy coordinates of the colors emitted at five different angles from a lens with a flat surface that is 1.3 mm above the upper surface 26 of substrate 27 and that has rounded edges 63 as shown in FIG. 6. The cross section of the lens surface more closely resembles a parabolic curve than a circular curve. The circles 62 are much more widely spaced than are the diamonds 59, the +’s 61, the x’s 60 or even the triangles 58. Although the shape of the lens with the 1.3 mm height has a smaller relative difference between the distance from the edge of the surface emitter to the lens surface at around $\pm 60^\circ$ and the distance from the surface emitter to the lens top at 0° , which should diminish any bluish ring at around $\pm 60^\circ$, the angular color performance of the quasi-parabolic lens is much less uniform than that of lenses shaped as portions of a sphere.

FIG. 15 is a flowchart illustrating steps 64-69 of a method of forming a lens that results in greater uniformity of the color of the emitted light. In a first step 64, LED dies are attached to an upper surface of a substrate. The maximum distance between the farthest apart edges of the LED dies is the surface emitter length. In step 65, after the LED dies are attached to the substrate, a layer of highly reflective material is deposited onto the substrate such that the layer does not cover the LED dies but is disposed between the dies. In step 66, a contact pad is deposited on the upper surface at each of the corners of the substrate. In step 67, phosphor particles are disbursed in a lens material, such as silicone or epoxy. The phosphor particles can be made of YAG or TAG.

In step 68, a lens is formed over the LED dies using the lens material containing the disbursed phosphor particles. The lens is shaped as a portion of a sphere. The dome height of the lens extends from the top of the dome to the upper surface of the substrate. The bottom chord length of the lens is the maximum length that the lens material extends over the upper surface of the substrate. The bottom chord length is less than twice the surface emitter length of the combined LED dies. The dome height of the lens is between 57% and 73% of the radius of the sphere of which the lens is a portion. The lens formed in step 68 is a means for reducing the non-uniformity over all emission angles in the color of the combined bluish light emitted by the LED dies and the yellowish light emitted by the phosphor particles. The lens reduces the non-uniformity in the color of the combined emitted bluish and yellowish light such that the CIE color coordinate x of the color does not change more than 0.004 over all angles relative to the upper surface of the substrate.

Each of the contact pads is laterally outside of the lens. Forming the lens also forms a flash layer over the upper surface of the substrate. The flash layer of lens material is about 50 microns thick. In step 69, the flash layer is removed from above the contact pads.

Although certain specific embodiments are described above for instructional purposes, the teachings of this patent document have general applicability and are not limited to the specific embodiments described above. Although the novel lens is described above as being molded over an array of LED dies, the angular color performance of an LED device is also

significantly improved where the novel lens is molded over a single LED die whose surface emitter length is more than half of the bottom chord length of the lens. Accordingly, various modifications, adaptations, and combinations of various features of the described embodiments can be practiced without departing from the scope of the invention as set forth in the claims.

What is claimed is:

1. An apparatus, comprising:

light emitting diode (LED) dies disposed on an upper surface of a substrate, wherein a surface emitter length is a maximum distance between farthest apart edges of the LED dies;

phosphor particles disbursed throughout a material molded over the LED dies on the upper surface of the substrate, wherein the LED dies emit bluish light, wherein the phosphor particles convert some of the bluish light to light with a longer wavelength, wherein the emitted bluish light combined with the emitted light with the longer wavelength exhibit a color at each angle relative to the upper surface, and wherein each color has a CIE-1931 color coordinate x; and

means for reducing a non-uniformity in the color exhibited over all angles relative to the upper surface such that the CIE-1931 color coordinate x of the color does not change more than 0.004 over all angles relative to the upper surface, wherein the surface emitter length is more than half a maximum length that the means extends over the upper surface of the substrate.

2. The apparatus of claim 1, wherein the means is shaped as a portion of a sphere having a dome and a radius, wherein a dome height extends from a top of the dome to the upper surface of the substrate, and wherein the dome height is between 57% and 73% of the radius.

3. The apparatus of claim 1, wherein the upper surface of the substrate is more reflective than are the LED dies.

4. The apparatus of claim 1, wherein the material is silicone.

5. The apparatus of claim 1, wherein the LED dies are arranged in a square matrix of LED dies.

6. The apparatus of claim 1, further comprising:

a layer of highly reflective material disposed over the upper surface of the substrate, wherein the layer does not extend under the LED dies and does not extend over the LED dies.

7. The apparatus of claim 6, wherein the layer contacts at least one edge of each of the LED dies.

8. The apparatus of claim 1, wherein the material is compression molded to form the means together with a flash layer over the upper surface of the substrate.

9. The apparatus of claim 8, further comprising:

contact pads disposed on the upper surface of the substrate, wherein the contact pads are outside of the means, and wherein the means and the flash layer are disposed over substantially all of the upper surface of the substrate except for over the contact pads.

10. An apparatus, comprising:

light emitting diode (LED) dies disposed on an upper surface of a substrate;

phosphor particles disbursed throughout a material molded over the LED dies on the upper surface, wherein the LED dies emit bluish light, wherein the phosphor particles convert some of the bluish light to light with a longer wavelength, wherein the emitted bluish light combined with the emitted light with the longer wave-

11

length exhibit a color at each angle relative to the upper surface, and wherein each color has a CIE-1931 color coordinate x; and

means for reducing a non-uniformity in the color exhibited over all angles relative to the upper surface such that the CIE-1931 color coordinate x of the color does not change more than 0.004 over all angles relative to the upper surface, wherein the means is shaped as a portion of a sphere having a dome and a radius, wherein a dome height extends from a top of the dome to the upper surface, and wherein the dome height is between 57% and 73% of the radius.

11. The apparatus of claim 10, wherein a surface emitter length is a maximum distance between farthest apart edges of the LED dies, and wherein the surface emitter length is more than half a maximum length that the means extends over the upper surface of the substrate.

12. The apparatus of claim 10, wherein the upper surface of the substrate is more reflective than are the LED dies.

13. The apparatus of claim 10, wherein the material is silicone.

12

14. The apparatus of claim 10, wherein the LED dies are arranged in a square matrix of LED dies.

15. The apparatus of claim 10, further comprising:

a layer of highly reflective material disposed over the upper surface of the substrate, wherein the layer does not extend under the LED dies and does not extend over the LED dies.

16. The apparatus of claim 15, wherein the layer contacts at least one edge of each of the LED dies.

17. The apparatus of claim 10, wherein the material is compression molded to form the means together with a flash layer over the upper surface of the substrate.

18. The apparatus of claim 17, further comprising:

contact pads disposed on the upper surface of the substrate, wherein the contact pads are outside of the dome, and wherein the dome and the flash layer are disposed over substantially all of the upper surface of the substrate except for over the contact pads.

* * * * *