



Bridgelux® CSP 2727 Series

Product Data Sheet DS967

Introduction

CSP 2727

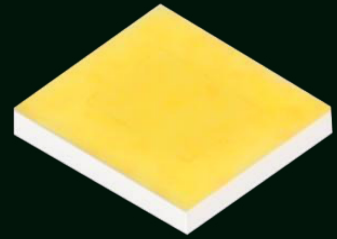

The Bridgelux Chip Scale Package (CSP) 2727 LED offers exceptional performance in an ultra compact size. This CSP LED is hot-color targeted which ensures that the LEDs fall within their specified color bin at the typical application conditions of 85°C. With its superior performance without bonding wires and ability to assemble a densely populated and high luminous flux LED board, the CSP 2727 provides unparalleled design-in flexibility for indoor and outdoor lighting applications. The CSP 2727 is ideal as a drop in replacement for emitters with an industry standard 2.7mm x 2.7mm footprint.

Features

- Competitive efficacy and lumen per dollar
- Industry-standard 2727 footprint, 1-sided emitter
- Excellent color maintenance
- Compatible with SMT
- Superior luminous flux at maximum current for reduced LED count
- Hot-color targeting ensures that color is within the ANSI bin at the typical application conditions of 85°C
- Enables 3- and 5-step MacAdam ellipse custom binning kits
- 120 degrees viewing angle
- Multiple CCT and CRI configurations for a wide range of lighting applications

Benefits

- Lower operating and manufacturing cost
- Ease of design and rapid go-to-market
- Uniform consistent white light
- Reliable and constant white point
- Environmentally friendly, complies with standards
- Design flexibility

Contents

Product Feature Map	2
Product Nomenclature	2
Product Test Conditions	2
Product Selection Guide	3
Performance at Commonly Used Drive Currents	5
Electrical and Thermal Characteristics	11
Absolute Maximum Ratings	12
Product Bin Definitions	13
Performance Curves	16
Typical Radiation Pattern	19
Typical Color Spectrum	20
Mechanical Dimensions	21
Reliability	22
Reflowing Characteristics	23
Packaging	24
Design Resources	26
Precautions	26
Disclaimers	26
About Bridgelux	27

Product Feature Map

Bridgelux CSP LED products offer exceptional performance and color quality all in a highly reliable, cost effective, compact package. Our CSP products come in industry standard package sizes and follow ANSI binning standards.

These LEDs are optimized for cost and performance, helping to ensure highly competitive system lumen per dollar performance while addressing the stringent efficacy and reliability standards required for modern lighting applications.

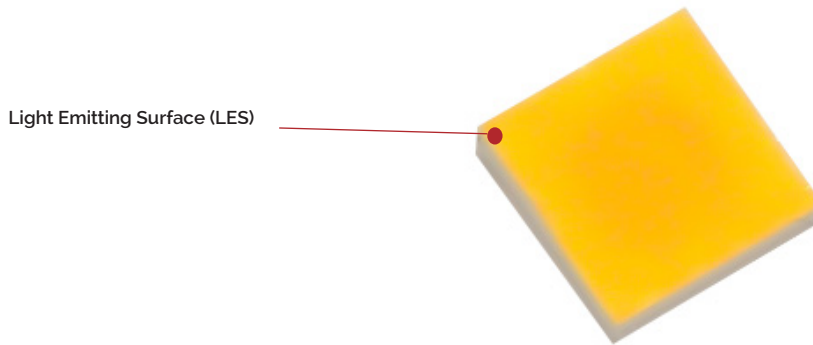

Product Nomenclature

The part number designation for Bridgelux CSP 2727 is explained as follows:

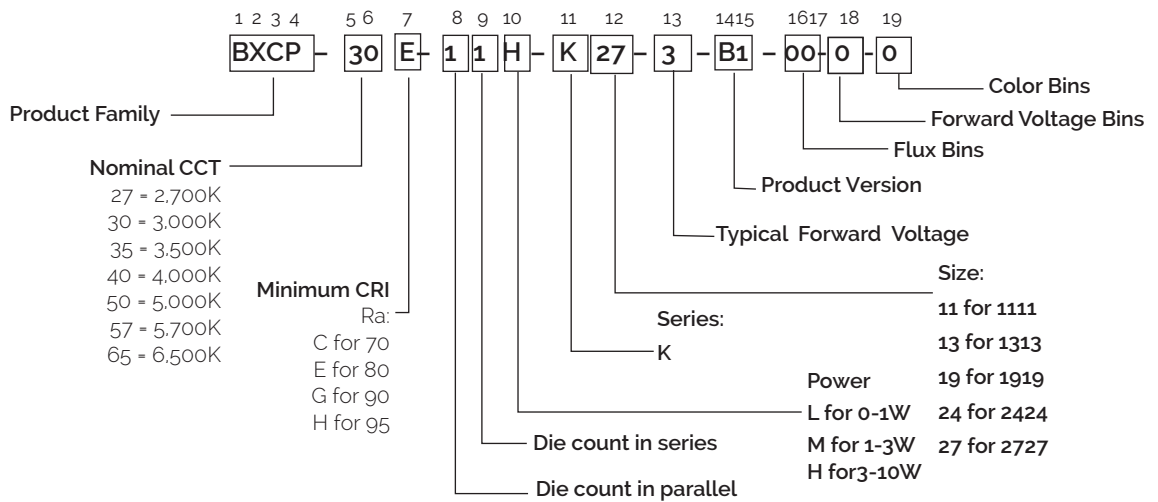

Product Test Conditions

Bridgelux CSP 2727 LEDs are tested and binned with a 10ms pulse of 700mA at T_j (junction temperature) = T_{sp} (solder point temperature) = 85°C. Luminous flux, color and forward voltage are binned at $T_j = T_{sp} = 85^\circ\text{C}$.

Product Selection Guide

The following product configurations are available:

Table 1: Selection Guide, Pulsed Measurement Data at 700mA ($T_j = T_{sp} = 25^\circ\text{C}$)

Part Number ^{1,6}	Nominal CCT ² (K)	CRI ^{3,5}	Nominal Drive Current (mA)	Forward Voltage ^{4,5} (V)			Typical Pulsed Flux ^{4,5} (lm)	Typical Power (W)	Typical Efficacy (lm/W)
				Min	Typical	Max			
BXCP-22C-11H-K27-3-B1-00-0-0	2200	70	700	2.70	2.79	3.00	313	2.0	160
BXCP-27C-11H-K27-3-B1-00-0-0	2700	70	700	2.70	2.79	3.00	363	2.0	186
BXCP-30C-11H-K27-3-B1-00-0-0	3000	70	700	2.70	2.79	3.00	381	2.0	195
BXCP-40C-11H-K27-3-B1-00-0-0	4000	70	700	2.70	2.79	3.00	401	2.0	205
BXCP-50C-11H-K27-3-B1-00-0-0	5000	70	700	2.70	2.79	3.00	401	2.0	205
BXCP-57C-11H-K27-3-B1-00-0-0	5700	70	700	2.70	2.79	3.00	401	2.0	205
BXCP-65C-11H-K27-3-B1-00-0-0	6500	70	700	2.70	2.79	3.00	397	2.0	203
BXCP-22E-11H-K27-3-B1-00-0-0	2200	80	700	2.70	2.79	3.00	269	2.0	138
BXCP-27E-11H-K27-3-B1-00-0-0	2700	80	700	2.70	2.79	3.00	324	2.0	166
BXCP-30E-11H-K27-3-B1-00-0-0	3000	80	700	2.70	2.79	3.00	343	2.0	176
BXCP-35E-11H-K27-3-B1-00-0-0	3500	80	700	2.70	2.79	3.00	352	2.0	180
BXCP-40E-11H-K27-3-B1-00-0-0	4000	80	700	2.70	2.79	3.00	368	2.0	188
BXCP-50E-11H-K27-3-B1-00-0-0	5000	80	700	2.70	2.79	3.00	368	2.0	188
BXCP-57E-11H-K27-3-B1-00-0-0	5700	80	700	2.70	2.79	3.00	368	2.0	188
BXCP-65E-11H-K27-3-B1-00-0-0	6500	80	700	2.70	2.79	3.00	357	2.0	183
BXCP-27G-11H-K27-3-B1-00-0-0	2700	90	700	2.70	2.79	3.00	283	2.0	145
BXCP-30G-11H-K27-3-B1-00-0-0	3000	90	700	2.70	2.79	3.00	298	2.0	153
BXCP-35G-11H-K27-3-B1-00-0-0	3500	90	700	2.70	2.79	3.00	311	2.0	159
BXCP-40G-11H-K27-3-B1-00-0-0	4000	90	700	2.70	2.79	3.00	322	2.0	165
BXCP-50G-11H-K27-3-B1-00-0-0	5000	90	700	2.70	2.79	3.00	322	2.0	165
BXCP-57G-11H-K27-3-B1-00-0-0	5700	90	700	2.70	2.79	3.00	322	2.0	165
BXCP-65G-11H-K27-3-B1-00-0-0	6500	90	700	2.70	2.79	3.00	314	2.0	161

Notes for Table 1:

- The last 6 characters (including hyphens '-') refer to nominal flux, nominal forward voltage, and color bins, respectively. "00-0-0" denotes the full distribution of flux, forward voltage, and 5 SDCM color.
Example: BXCP-30E-11H-K27-3-B1-00-0-0 refers to the full distribution of flux, forward voltage, and color within a 3000K 5-step ANSI standard chromaticity region with a minimum of 80 CRI.
- Product CCT is hot targeted at $T_{sp} = 85^\circ\text{C}$. Nominal CCT as defined by ANSI C78.377-2011.
- Listed CRIs are minimum values and include test tolerance.
- Products tested under pulsed condition (10ms pulse width) at nominal drive current where $T_j = T_{sp} = 25^\circ\text{C}$.
- Bridgelux maintains a $\pm 7.5\%$ tolerance on luminous flux measurements, $\pm 0.1\text{V}$ tolerance on forward voltage measurements, and ± 2 tolerance on CRI measurements for the CSP.
- Refer to Table 6 and Table 7 for Bridgelux CSP Luminous Flux Binning and Forward Voltage Binning information.

Product Selection Guide

Table 2: Selection Guide, Pulsed Measurement Data at 700mA ($T_j = T_{sp} = 85^\circ\text{C}$)

Part Number ^{1,5}	Nominal CCT ² (K)	CRI ^{3,4}	Nominal Drive Current (mA)	Forward Voltage ⁴ (V)			Typical Pulsed Flux ⁴ (lm)	Typical Power (W)	Typical Efficacy (lm/W)
				Min	Typical	Max			
BXCP-22C-11H-K27-3-B1-00-0-0	2200	70	700	2.60	2.68	2.90	285	1.9	152
BXCP-27C-11H-K27-3-B1-00-0-0	2700	70	700	2.60	2.68	2.90	330	1.9	176
BXCP-30C-11H-K27-3-B1-00-0-0	3000	70	700	2.60	2.68	2.90	347	1.9	185
BXCP-40C-11H-K27-3-B1-00-0-0	4000	70	700	2.60	2.68	2.90	365	1.9	195
BXCP-50C-11H-K27-3-B1-00-0-0	5000	70	700	2.60	2.68	2.90	365	1.9	195
BXCP-57C-11H-K27-3-B1-00-0-0	5700	70	700	2.60	2.68	2.90	365	1.9	195
BXCP-65C-11H-K27-3-B1-00-0-0	6500	70	700	2.60	2.68	2.90	361	1.9	192
BXCP-22E-11H-K27-3-B1-00-0-0	2200	80	700	2.60	2.68	2.90	245	1.9	131
BXCP-27E-11H-K27-3-B1-00-0-0	2700	80	700	2.60	2.68	2.90	295	1.9	157
BXCP-30E-11H-K27-3-B1-00-0-0	3000	80	700	2.60	2.68	2.90	312	1.9	166
BXCP-35E-11H-K27-3-B1-00-0-0	3500	80	700	2.60	2.68	2.90	320	1.9	171
BXCP-40E-11H-K27-3-B1-00-0-0	4000	80	700	2.60	2.68	2.90	335	1.9	179
BXCP-50E-11H-K27-3-B1-00-0-0	5000	80	700	2.60	2.68	2.90	335	1.9	179
BXCP-57E-11H-K27-3-B1-00-0-0	5700	80	700	2.60	2.68	2.90	335	1.9	179
BXCP-65E-11H-K27-3-B1-00-0-0	6500	80	700	2.60	2.68	2.90	325	1.9	173
BXCP-27G-11H-K27-3-B1-00-0-0	2700	90	700	2.60	2.68	2.90	255	1.9	136
BXCP-30G-11H-K27-3-B1-00-0-0	3000	90	700	2.60	2.68	2.90	268	1.9	143
BXCP-35G-11H-K27-3-B1-00-0-0	3500	90	700	2.60	2.68	2.90	280	1.9	149
BXCP-40G-11H-K27-3-B1-00-0-0	4000	90	700	2.60	2.68	2.90	290	1.9	155
BXCP-50G-11H-K27-3-B1-00-0-0	5000	90	700	2.60	2.68	2.90	290	1.9	155
BXCP-57G-11H-K27-3-B1-00-0-0	5700	90	700	2.60	2.68	2.90	290	1.9	155
BXCP-65G-11H-K27-3-B1-00-0-0	6500	90	700	2.60	2.68	2.90	283	1.9	151

Notes for Table 2:

- The last 6 characters (including hyphens '-') refer to nominal flux, nominal forward voltage, and color bins, respectively. "00-0-0" denotes the full distribution of flux, forward voltage, and 5 SDCM color.
Example: BXCP-30E-11H-K27-3-B1-00-0-0 refers to the full distribution of flux, forward voltage, and color within a 3000K 5-step ANSI standard chromaticity region with a minimum of 80 CRI.
- Product CCT is hot targeted at $T_{sp} = 85^\circ\text{C}$. Nominal CCT as defined by ANSI C78.377-2011.
- Listed CRIs are minimum values and include test tolerance.
- Bridgelux maintains a $\pm 7.5\%$ tolerance on luminous flux measurements, $\pm 0.1\text{V}$ tolerance on forward voltage measurements, and ± 2 tolerance on CRI measurements for the CSP.
- Refer to Table 6 and Table 7 for Bridgelux CSP Luminous Flux Binning and Forward Voltage Binning information.
- Products tested under pulsed condition (10ms pulse width) at nominal drive current where $T_j = T_{sp} = 85^\circ\text{C}$.

Performance at Commonly Used Drive Currents

CSP 2727 LEDs specifications at nominal drive current are shown in Table 1 and Table 2. CSP 2727 may also be driven at other drive currents dependent on specific application design requirements. The performance at any drive current can be derived from the current vs. voltage characteristics shown in Figure 2 and the relative luminous flux vs. current characteristics shown in Figure 3. The performance at commonly used drive currents is summarized in Table 3.

Table 3: Performance at Commonly Used Drive Currents

Part Number	CRI	Drive Current ¹ (mA)	Typical V_f $T_{sp} = 25^\circ\text{C}$ (V)	Typical Power $T_{sp} = 25^\circ\text{C}$ (W)	Typical Pulsed Flux ² $T_{sp} = 25^\circ\text{C}$ (lm)	Typical Pulsed Flux ³ $T_{sp} = 85^\circ\text{C}$ (lm)	Typical Efficacy $T_{sp} = 25^\circ\text{C}$ (lm/W)
BXCP-22C-11H-K27-3-B1-00-0-0	70	50	2.59	0.1	23	21	178
		200	2.67	0.5	95	86	177
		350	2.72	1.0	163	148	171
		700	2.79	2.0	313	285	160
		1000	2.85	2.9	433	394	152
		1200	2.89	3.5	512	466	148
		1500	2.95	4.4	618	562	140
		1800	3.00	5.4	723	658	134
BXCP-27C-11H-K27-3-B1-00-0-0	70	50	2.59	0.1	27	24	206
		200	2.67	0.5	110	100	205
		350	2.72	1.0	189	172	198
		700	2.79	2.0	363	330	185
		1000	2.85	2.9	501	456	176
		1200	2.89	3.5	593	540	171
		1500	2.95	4.4	716	651	162
		1800	3.00	5.4	838	763	155
BXCP-30C-11H-K27-3-B1-00-0-0	70	50	2.59	0.1	28	26	216
		200	2.67	0.5	115	105	216
		350	2.72	1.0	198	181	209
		700	2.79	2.0	381	347	195
		1000	2.85	2.9	527	480	185
		1200	2.89	3.5	624	568	180
		1500	2.95	4.4	752	685	170
		1800	3.00	5.4	881	802	163
BXCP-40C-11H-K27-3-B1-00-0-0	70	50	2.59	0.1	30	27	228
		200	2.67	0.5	121	110	227
		350	2.72	1.0	209	190	220
		700	2.79	2.0	401	365	205
		1000	2.85	2.9	555	505	194
		1200	2.89	3.5	656	597	189
		1500	2.95	4.4	792	720	179
		1800	3.00	5.4	927	844	172
		2000	3.03	6.1	1009	918	166

Notes for Table 3:

1. Alternate drive currents in Table 3 are provided for reference only and are not a guarantee of performance.
2. Bridgelux maintains a $\pm 7.5\%$ tolerance on flux measurements.
3. Typical pulsed performance values are provided as reference only and are not a guarantee of performance.

Performance at Commonly Used Drive Currents

Table 3: Performance at Commonly Used Drive Currents (Continued)

Part Number	CRI	Drive Current ¹ (mA)	Typical V_f $T_{sp} = 25^\circ\text{C}$ (V)	Typical Power $T_{sp} = 25^\circ\text{C}$ (W)	Typical Pulsed Flux ² $T_{sp} = 25^\circ\text{C}$ (lm)	Typical Pulsed Flux ³ $T_{sp} = 85^\circ\text{C}$ (lm)	Typical Efficacy $T_{sp} = 25^\circ\text{C}$ (lm/W)
BXCP-50C-11H-K27-3-B1-00-0-0	70	50	2.59	0.1	30	27	228
		200	2.67	0.5	121	110	227
		350	2.72	1.0	209	190	220
		700	2.79	2.0	401	365	205
		1000	2.85	2.9	555	505	194
		1200	2.89	3.5	656	597	189
		1500	2.95	4.4	792	720	179
		1800	3.00	5.4	927	844	172
BXCP-57C-11H-K27-3-B1-00-0-0	70	50	2.59	0.1	30	27	228
		200	2.67	0.5	121	110	227
		350	2.72	1.0	209	190	220
		700	2.79	2.0	401	365	205
		1000	2.85	2.9	555	505	194
		1200	2.89	3.5	656	597	189
		1500	2.95	4.4	792	720	179
		1800	3.00	5.4	927	844	172
BXCP-65C-11H-K27-3-B1-00-0-0	70	50	2.59	0.1	29	27	225
		200	2.67	0.5	120	109	225
		350	2.72	1.0	207	188	217
		700	2.79	2.0	397	361	203
		1000	2.85	2.9	548	499	192
		1200	2.89	3.5	649	591	187
		1500	2.95	4.4	783	712	177
		1800	3.00	5.4	917	834	170
BXCP-22E-11H-K27-3-B1-00-0-0	80	50	2.59	0.1	20	18	153
		200	2.67	0.5	81	74	153
		350	2.72	1.0	140	128	147
		700	2.79	2.0	269	245	138
		1000	2.85	2.9	372	339	131
		1200	2.89	3.5	441	401	127
		1500	2.95	4.4	531	484	120
		1800	3.00	5.4	622	566	115
2000	3.03	6.1	677	616	112		

Notes for Table 3:

1. Alternate drive currents in Table 3 are provided for reference only and are not a guarantee of performance.
2. Bridgelux maintains a $\pm 7.5\%$ tolerance on flux measurements.
3. Typical pulsed performance values are provided as reference only and are not a guarantee of performance.

Performance at Commonly Used Drive Currents

Table 3: Performance at Commonly Used Drive Currents (Continued)

Part Number	CRI	Drive Current ¹ (mA)	Typical V_f $T_{sp} = 25^\circ\text{C}$ (V)	Typical Power $T_{sp} = 25^\circ\text{C}$ (W)	Typical Pulsed Flux ² $T_{sp} = 25^\circ\text{C}$ (lm)	Typical Pulsed Flux ³ $T_{sp} = 85^\circ\text{C}$ (lm)	Typical Efficacy $T_{sp} = 25^\circ\text{C}$ (lm/W)
BXCP-27E-11H-K27-3-B1-00-0-0	80	50	2.59	0.1	24	22	184
		200	2.67	0.5	98	89	184
		350	2.72	1.0	169	154	177
		700	2.79	2.0	324	295	166
		1000	2.85	2.9	448	408	157
		1200	2.89	3.5	530	483	153
		1500	2.95	4.4	640	582	145
		1800	3.00	5.4	749	682	139
BXCP-30E-11H-K27-3-B1-00-0-0	80	50	2.59	0.1	25	23	195
		200	2.67	0.5	104	94	194
		350	2.72	1.0	179	162	188
		700	2.79	2.0	343	312	176
		1000	2.85	2.9	474	431	166
		1200	2.89	3.5	561	511	162
		1500	2.95	4.4	677	616	153
		1800	3.00	5.4	793	721	147
BXCP-35E-11H-K27-3-B1-00-0-0	80	50	2.59	0.1	26	24	200
		200	2.67	0.5	106	97	199
		350	2.72	1.0	183	167	192
		700	2.79	2.0	352	320	180
		1000	2.85	2.9	486	442	171
		1200	2.89	3.5	575	524	166
		1500	2.95	4.4	694	632	157
		1800	3.00	5.4	813	740	150
BXCP-40E-11H-K27-3-B1-00-0-0	80	50	2.59	0.1	27	25	209
		200	2.67	0.5	111	101	209
		350	2.72	1.0	192	174	202
		700	2.79	2.0	368	335	188
		1000	2.85	2.9	509	463	179
		1200	2.89	3.5	602	548	174
		1500	2.95	4.4	727	661	164
		1800	3.00	5.4	851	774	158
2000	3.03	6.1	926	843	153		

Notes for Table 3:

1. Alternate drive currents in Table 3 are provided for reference only and are not a guarantee of performance.
2. Bridgelux maintains a $\pm 7.5\%$ tolerance on flux measurements.
3. Typical pulsed performance values are provided as reference only and are not a guarantee of performance.

Performance at Commonly Used Drive Currents

Table 3: Performance at Commonly Used Drive Currents (Continued)

Part Number	CRI	Drive Current ¹ (mA)	Typical V_f $T_{sp} = 25^\circ\text{C}$ (V)	Typical Power $T_{sp} = 25^\circ\text{C}$ (W)	Typical Pulsed Flux ² $T_{sp} = 25^\circ\text{C}$ (lm)	Typical Pulsed Flux ³ $T_{sp} = 85^\circ\text{C}$ (lm)	Typical Efficacy $T_{sp} = 25^\circ\text{C}$ (lm/W)
BXCP-50E-11H-K27-3-B1-00-0-0	80	50	2.59	0.1	27	25	209
		200	2.67	0.5	111	101	209
		350	2.72	1.0	192	174	202
		700	2.79	2.0	368	335	188
		1000	2.85	2.9	509	463	179
		1200	2.89	3.5	602	548	174
		1500	2.95	4.4	727	661	164
		1800	3.00	5.4	851	774	158
BXCP-57E-11H-K27-3-B1-00-0-0	80	50	2.59	0.1	27	25	209
		200	2.67	0.5	111	101	209
		350	2.72	1.0	192	174	202
		700	2.79	2.0	368	335	188
		1000	2.85	2.9	509	463	179
		1200	2.89	3.5	602	548	174
		1500	2.95	4.4	727	661	164
		1800	3.00	5.4	851	774	158
BXCP-65E-11H-K27-3-B1-00-0-0	80	50	2.59	0.1	26	24	203
		200	2.67	0.5	108	98	202
		350	2.72	1.0	186	169	195
		700	2.79	2.0	357	325	183
		1000	2.85	2.9	494	449	173
		1200	2.89	3.5	584	532	168
		1500	2.95	4.4	705	642	159
		1800	3.00	5.4	826	751	153
		2000	3.03	6.1	899	818	148

Notes for Table 3:

1. Alternate drive currents in Table 3 are provided for reference only and are not a guarantee of performance.
2. Bridgelux maintains a $\pm 7.5\%$ tolerance on flux measurements.
3. Typical pulsed performance values are provided as reference only and are not a guarantee of performance.

Performance at Commonly Used Drive Currents

Table 3: Performance at Commonly Used Drive Currents (Continued)

Part Number	CRI	Drive Current ¹ (mA)	Typical V_f $T_{sp} = 25^\circ\text{C}$ (V)	Typical Power $T_{sp} = 25^\circ\text{C}$ (W)	Typical Pulsed Flux ² $T_{sp} = 25^\circ\text{C}$ (lm)	Typical Pulsed Flux ³ $T_{sp} = 85^\circ\text{C}$ (lm)	Typical Efficacy $T_{sp} = 25^\circ\text{C}$ (lm/W)
BXCP-27G-11H-K27-3-B1-00-0-0	90	50	2.59	0.1	21	19	161
		200	2.67	0.5	86	77	161
		350	2.72	1.0	148	133	155
		700	2.79	2.0	283	255	145
		1000	2.85	2.9	392	353	137
		1200	2.89	3.5	464	417	134
		1500	2.95	4.4	559	503	126
		1800	3.00	5.4	655	589	121
BXCP-30G-11H-K27-3-B1-00-0-0	90	50	2.59	0.1	22	20	169
		200	2.67	0.5	90	81	169
		350	2.72	1.0	155	140	163
		700	2.79	2.0	298	268	152
		1000	2.85	2.9	412	371	144
		1200	2.89	3.5	487	439	140
		1500	2.95	4.4	588	529	133
		1800	3.00	5.4	688	620	127
BXCP-35G-11H-K27-3-B1-00-0-0	90	50	2.59	0.1	23	21	177
		200	2.67	0.5	94	85	176
		350	2.72	1.0	162	146	170
		700	2.79	2.0	311	280	159
		1000	2.85	2.9	430	387	151
		1200	2.89	3.5	509	458	147
		1500	2.95	4.4	614	553	139
		1800	3.00	5.4	719	647	133
BXCP-40G-11H-K27-3-B1-00-0-0	90	50	2.59	0.1	24	21	183
		200	2.67	0.5	97	88	183
		350	2.72	1.0	168	151	176
		700	2.79	2.0	322	290	165
		1000	2.85	2.9	446	401	156
		1200	2.89	3.5	527	475	152
		1500	2.95	4.4	636	572	144
		1800	3.00	5.4	745	670	138
		2000	3.03	6.1	811	730	134

Notes for Table 3:

1. Alternate drive currents in Table 3 are provided for reference only and are not a guarantee of performance.
2. Bridgelux maintains a $\pm 7.5\%$ tolerance on flux measurements.
3. Typical pulsed performance values are provided as reference only and are not a guarantee of performance.

Performance at Commonly Used Drive Currents

Table 3: Performance at Commonly Used Drive Currents (Continued)

Part Number	CRI	Drive Current ¹ (mA)	Typical V_f $T_{sp} = 25^\circ\text{C}$ (V)	Typical Power $T_{sp} = 25^\circ\text{C}$ (W)	Typical Pulsed Flux ² $T_{sp} = 25^\circ\text{C}$ (lm)	Typical Pulsed Flux ³ $T_{sp} = 85^\circ\text{C}$ (lm)	Typical Efficacy $T_{sp} = 25^\circ\text{C}$ (lm/W)
BXCP-50G-11H-K27-3-B1-00-0-0	90	50	2.59	0.1	24	21	183
		200	2.67	0.5	97	88	183
		350	2.72	1.0	168	151	176
		700	2.79	2.0	322	290	165
		1000	2.85	2.9	446	401	156
		1200	2.89	3.5	527	475	152
		1500	2.95	4.4	636	572	144
		1800	3.00	5.4	745	670	138
BXCP-57G-11H-K27-3-B1-00-0-0	90	50	2.59	0.1	24	21	183
		200	2.67	0.5	97	88	183
		350	2.72	1.0	168	151	176
		700	2.79	2.0	322	290	165
		1000	2.85	2.9	446	401	156
		1200	2.89	3.5	527	475	152
		1500	2.95	4.4	636	572	144
		1800	3.00	5.4	745	670	138
BXCP-65G-11H-K27-3-B1-00-0-0	90	50	2.59	0.1	23	21	179
		200	2.67	0.5	95	85	178
		350	2.72	1.0	164	147	172
		700	2.79	2.0	314	283	161
		1000	2.85	2.9	435	391	152
		1200	2.89	3.5	515	463	148
		1500	2.95	4.4	621	559	140
		1800	3.00	5.4	727	654	135
		2000	3.03	6.1	791	712	130

Notes for Table 3:

1. Alternate drive currents in Table 3 are provided for reference only and are not a guarantee of performance.
2. Bridgelux maintains a $\pm 7.5\%$ tolerance on flux measurements.
3. Typical pulsed performance values are provided as reference only and are not a guarantee of performance.

Electrical and Thermal Characteristics

Table 4: Electrical and Thermal Characteristics

Part Number ¹	Drive Current (mA)	Forward Voltage ^{2,3} (V)			Typical Temperature Coefficient of Forward Voltage ⁴ $\Delta V_f / \Delta T$ (mV/°C)	Typical Thermal Resistance Junction to Solder Point ^{5,6} R_{j-sp} (°C/W)
		Minimum	Typical	Maximum		
BXCP-xxx-11H-K27-3-B1-00-0-0	700	2.60	2.68	2.90	-1.0	0.5

Notes for Table 4:

1. The last 6 characters (including hyphens '-') refer to nominal flux, nominal forward voltage, and color bins, respectively. "00-0-0" denotes the full distribution of flux, forward voltage, and 5 SDCM color.

Example: BXCP-30E-11H-K27-3-B1-00-0-0 refers to the full distribution of flux, forward voltage, and color within a 3000K 5-step ANSI standard chromaticity region with a minimum of 80 CRI.

2. Products tested under pulsed condition (10ms pulse width) where $T_{sp} = 85^\circ\text{C}$.

3. Bridgelux maintains a tolerance of $\pm 0.1\text{V}$ on forward voltage measurements.

4. Products measured between 25°C and 105°C under pulsed condition (10ms pulse width).

5. Thermal Resistance values based on 3000K 80 CRI product.

6. Thermal resistance value was calculated using total electrical input power; optical power was not subtracted from input power.

Absolute Maximum Ratings

Table 5: Maximum Ratings

Parameter	Maximum Rating
LED Junction Temperature (T_j)	135°C
Storage Temperature	-40°C to +125°C
Operating Solder Point Temperature (T_{sp})	-40°C to +105°C
Soldering Temperature	260°C or lower for a maximum of 10 seconds
Maximum Drive Current ¹	2000mA
Maximum Peak Pulsed Forward Current ²	2800mA
Maximum Reverse Voltage ³	-5V
Moisture Sensitivity Rating	MSL 3
Electrostatic Discharge	2kV HBM. JEDEC-JS-001-HBM and JEDEC-JS-001-2012

Notes for Table 5:

1. The maximum drive current is limited depending on the solder point temperature. Refer to Figure 7.
2. Bridgelux recommends a maximum duty cycle of 10% and pulse width of 10 ms when operating CSP LED at maximum peak pulsed current specified. Maximum peak pulsed currents indicate values where CSP LED can be driven without catastrophic failures.
3. Light emitting diodes are not designed to be driven in reverse voltage and will not produce light under this condition. Maximum rating provided for reference only.

Product Bin Definitions

Table 6 lists the standard photometric luminous flux bins for Bridgelux CSP 2727 LEDs. Although several bins are outlined, product availability in a particular bin varies by production run and by product performance. Not all bins are available in all CCTs.

Table 6: Luminous Flux Bin Definitions at 700mA, $T_{sp} = 85^{\circ}\text{C}$

Bin Code	Minimum	Maximum	Unit	Condition
C8	130	150	lm	$I_F = 700\text{mA}$
C9	150	170		
D2	170	190		
D3	190	210		
D4	210	230		
D5	230	250		
D6	250	270		
D7	270	290		
D8	290	310		
D9	310	330		
E6	330	350		
E7	350	370		
E8	370	390		

Note for Table 6:

1. Bridgelux maintains a tolerance of $\pm 7.5\%$ on luminous flux measurements.

Table 7: Forward Voltage Bin Definition at 700mA, $T_{sp} = 85^{\circ}\text{C}$

Bin Code	Minimum	Maximum	Unit	Condition
C	2.6	2.8	V	$I_F = 700\text{mA}$
D	2.8	3.0		
E	3.0	3.2		

Note for Table 7:

1. Bridgelux maintains a tolerance of $\pm 0.1\text{V}$ on forward voltage measurements.

Product Bin Definitions

Table 8: 3- and 5-step MacAdam Ellipse Color Bin Definitions ($T_{sp}=85^{\circ}\text{C}$)

Table 8: 3- and 5-step MacAdam Ellipse Color Bin Definitions ($T_{sp}=85^{\circ}\text{C}$)							
CCT	Color Space	Center Point		Major Axis	Minor Axis	θ (Angle)	Color Bin
		x	y				
1800K	3	0.5496	0.4082	0.00698	0.00393	40.000	3
	5			0.01164	0.00655		5(E/F/G/H)
2000K	3	0.5251	0.4120	0.00723	0.00399	51.000	3
	5			0.01205	0.00665		5(E/F/G/H)
2200K	3	0.5056	0.4152	0.00723	0.00399	51.918	3
	5			0.01205	0.00665		5(E/F/G/H)
2700K	3	0.4578	0.4101	0.00810	0.00420	53.700	3
	5			0.01350	0.00700		5(E/F/G/H)
3000K	3	0.4338	0.4030	0.00834	0.00408	53.220	3
	5			0.01390	0.00680		5(E/F/G/H)
3500K	3	0.4073	0.3917	0.00927	0.00414	54.000	3
	5			0.01545	0.00690		5(E/F/G/H)
4000K	3	0.3818	0.3797	0.00939	0.00402	53.720	3
	5			0.01565	0.00670		5(E/F/G/H)
5000K	3	0.3447	0.3553	0.00822	0.00354	59.620	3
	5			0.01370	0.00590		5(E/F/G/H)
5700K	3	0.3287	0.3417	0.00746	0.00320	59.090	3
	5			0.01243	0.00533		5(E/F/G/H)
6500K	3	0.3123	0.3282	0.00669	0.00285	58.570	3
	5			0.01115	0.00475		5(E/F/G/H)

Note for Table 8:

1. Bridgelux maintains a tolerance of ± 0.007 on x and y color coordinates in the CIE 1931 color space.
2. MacAdam Ellipse Color bin code 3(3 SDCM)/ EFGH(5 SDCM).

Product Bin Definitions

Figure 1: C.I.E. 1931 Chromaticity Diagram (Color Bin Structure, $T_{sp} = 85^{\circ}\text{C}$)

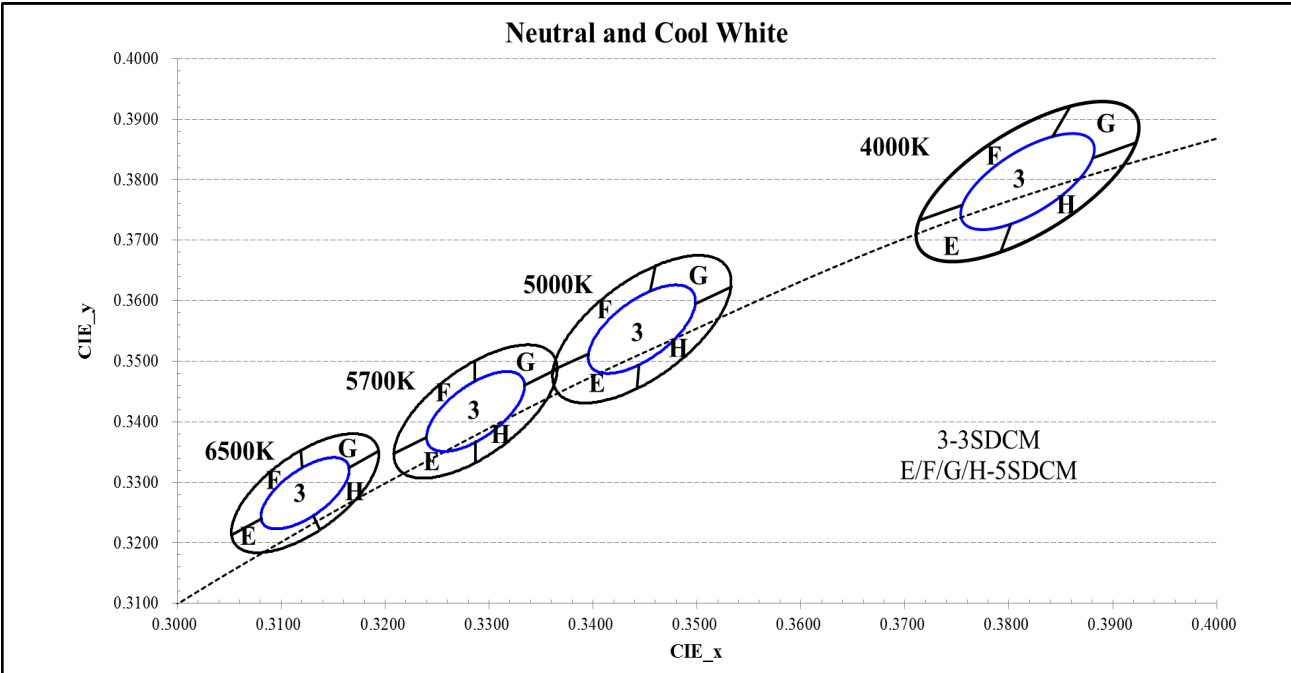
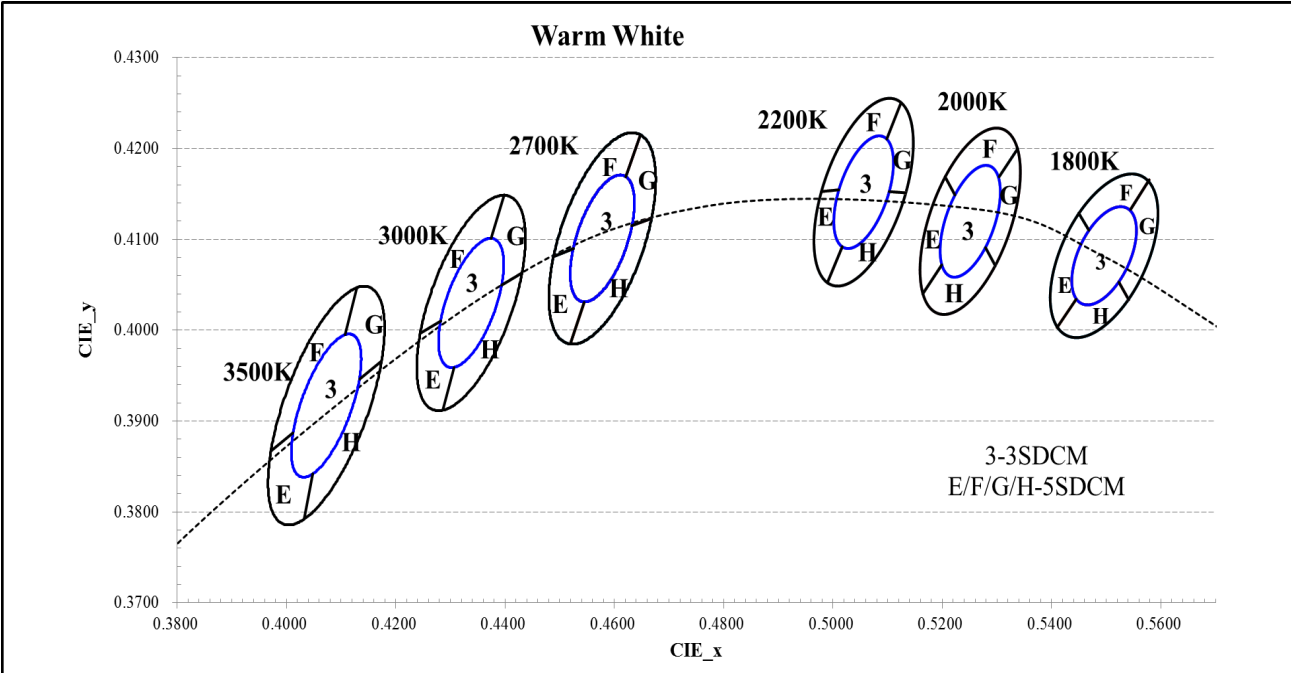

Performance Curves

Figure 2: Drive Current vs. Voltage ($T_{sp}=85^{\circ}\text{C}$)

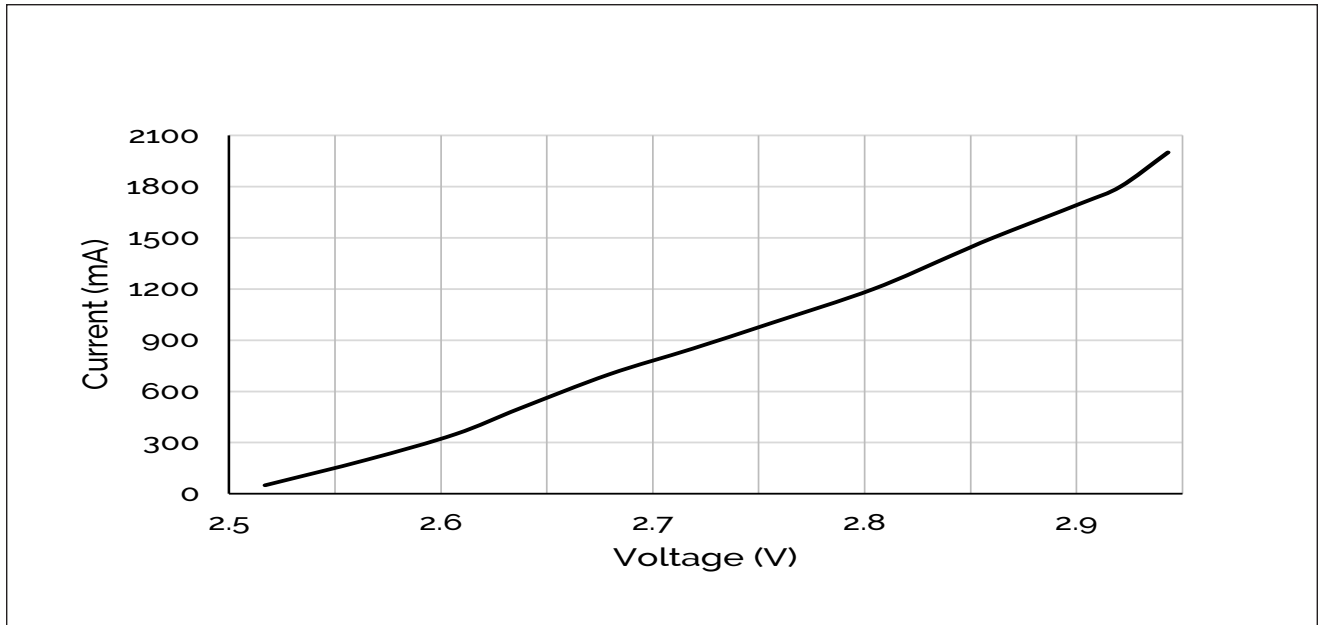
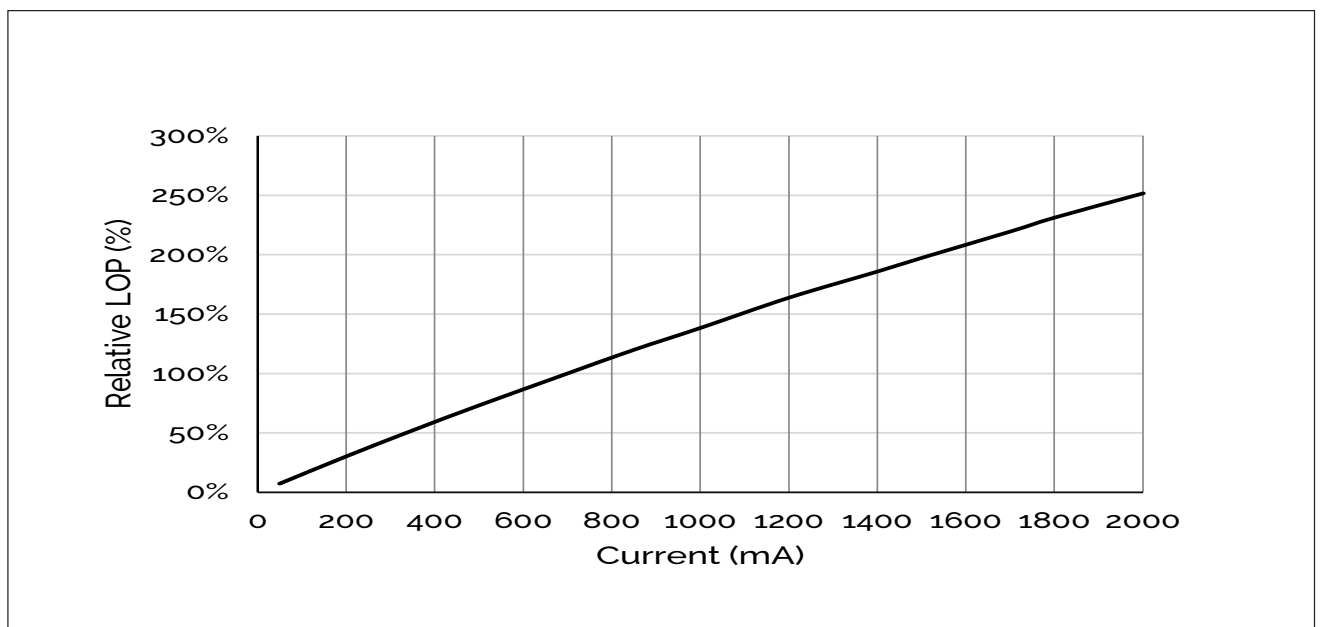

Figure 3: Relative Luminous Flux vs. Drive Current ($T_{sp}=85^{\circ}\text{C}$)



Note for Figure 3:

1. Bridgelux does not recommend driving this CSP LED at low current (< 30mA). Doing so may produce unpredictable results. Pulse width modulation (PWM) is recommended for dimming effects.

Performance Curves

Figure 4: Relative Flux vs. Solder Point Temperature_700mA

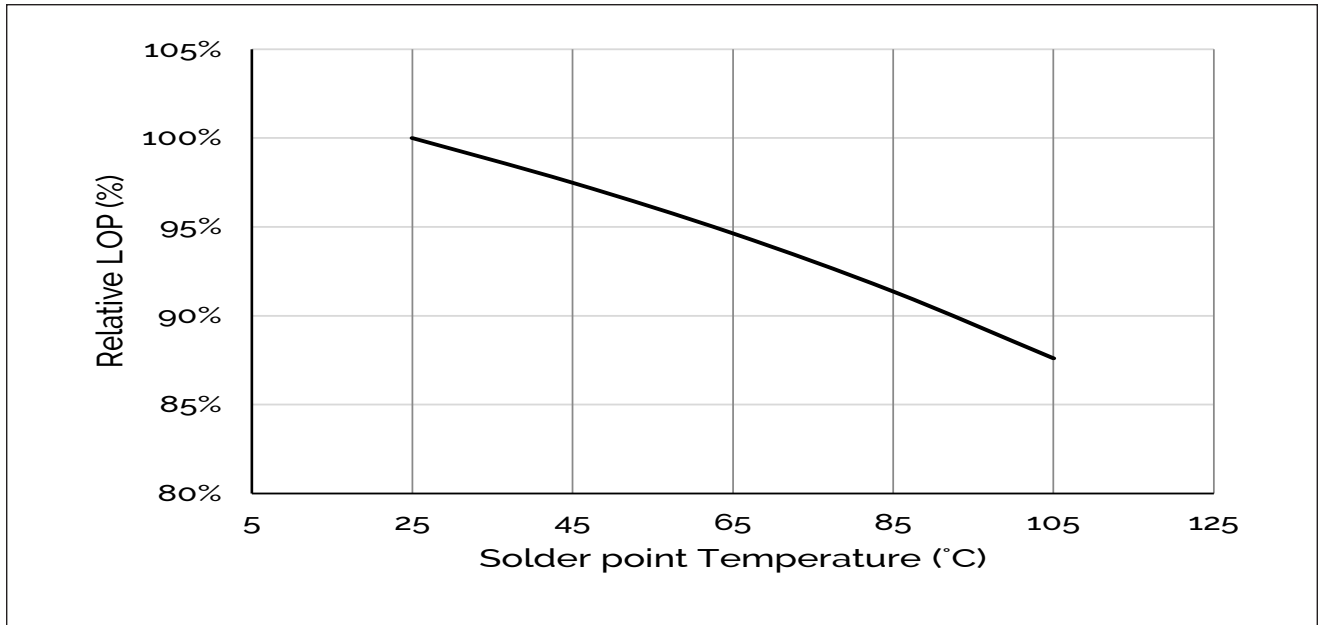
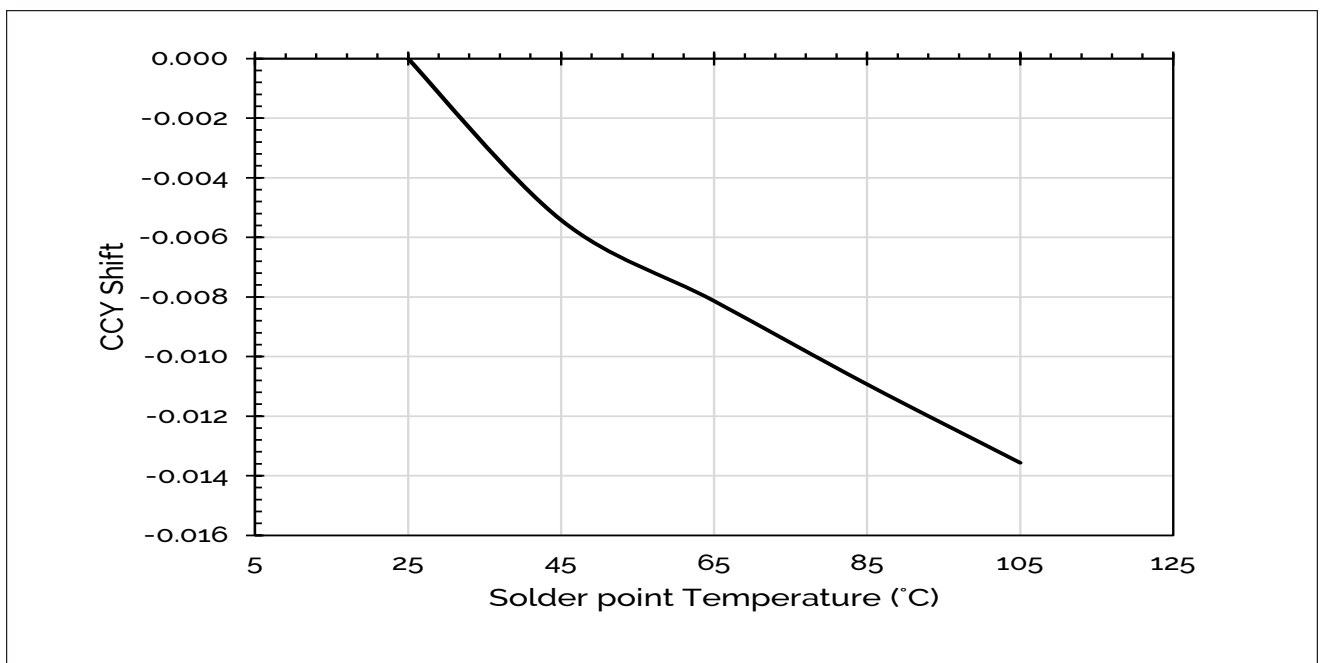

Figure 5: Typical ccY Shift vs. Solder Point Temperature_700mA



Notes for Figures 4 & 5:

1. Characteristics shown for warm white based on 3000K and 80 CRI.
2. For other color SKUs, the shift in color will vary. Please contact your Bridgelux Sales Representative for more information.

Performance Curves

Figure 6: Typical ccx Shift vs. Solder Point Temperature_700mA

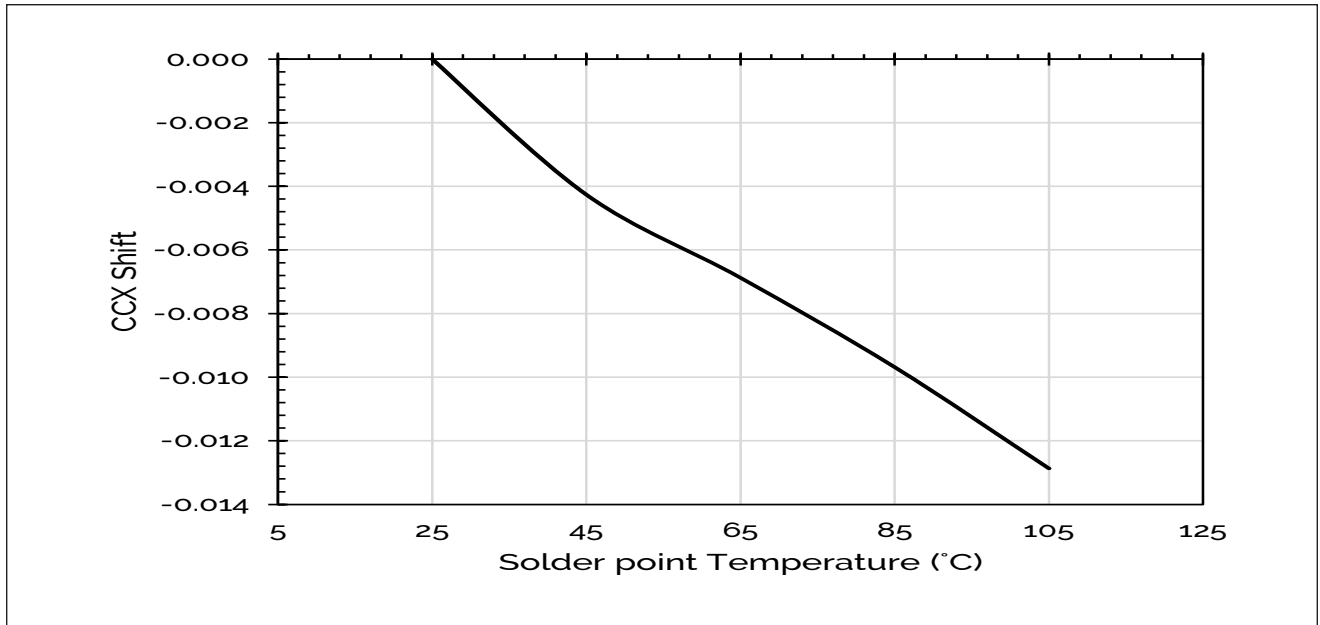

Notes for Figure 6:

1. Characteristics shown for warm white based on 3000K and 80 CRI.
2. For other color SKUs, the shift in color will vary. Please contact your Bridgelux Sales Representative for more information.

Figure 7: Drive Current vs Solder Point Temperature

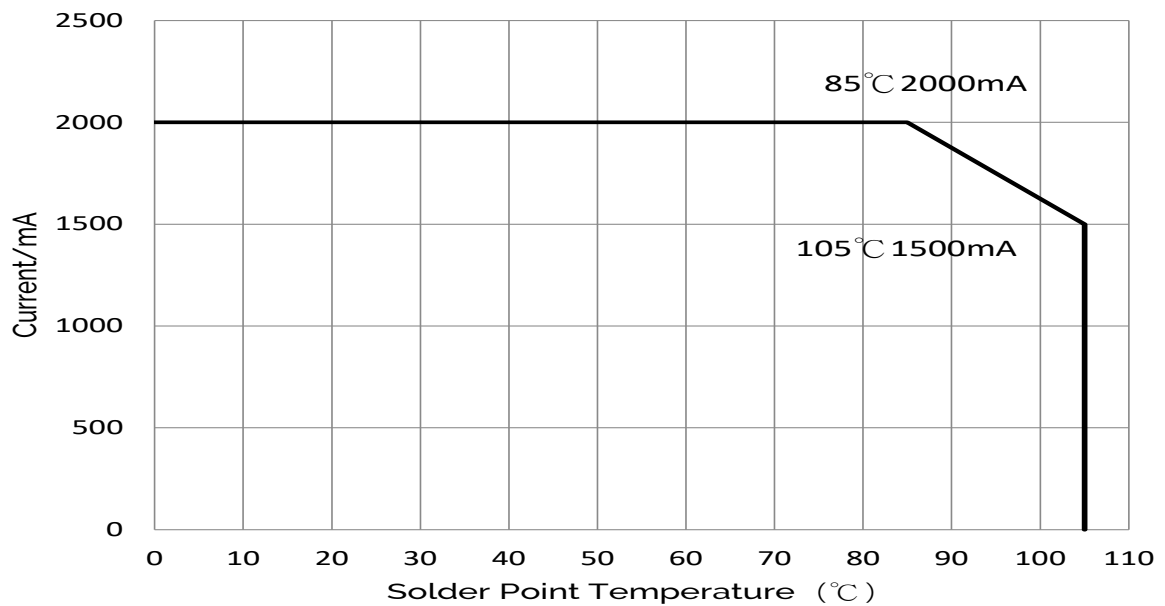

Typical Radiation Pattern

Figure 8: Typical Spatial Radiation Pattern at 700mA, $T_{sp} = 25^{\circ}\text{C}$

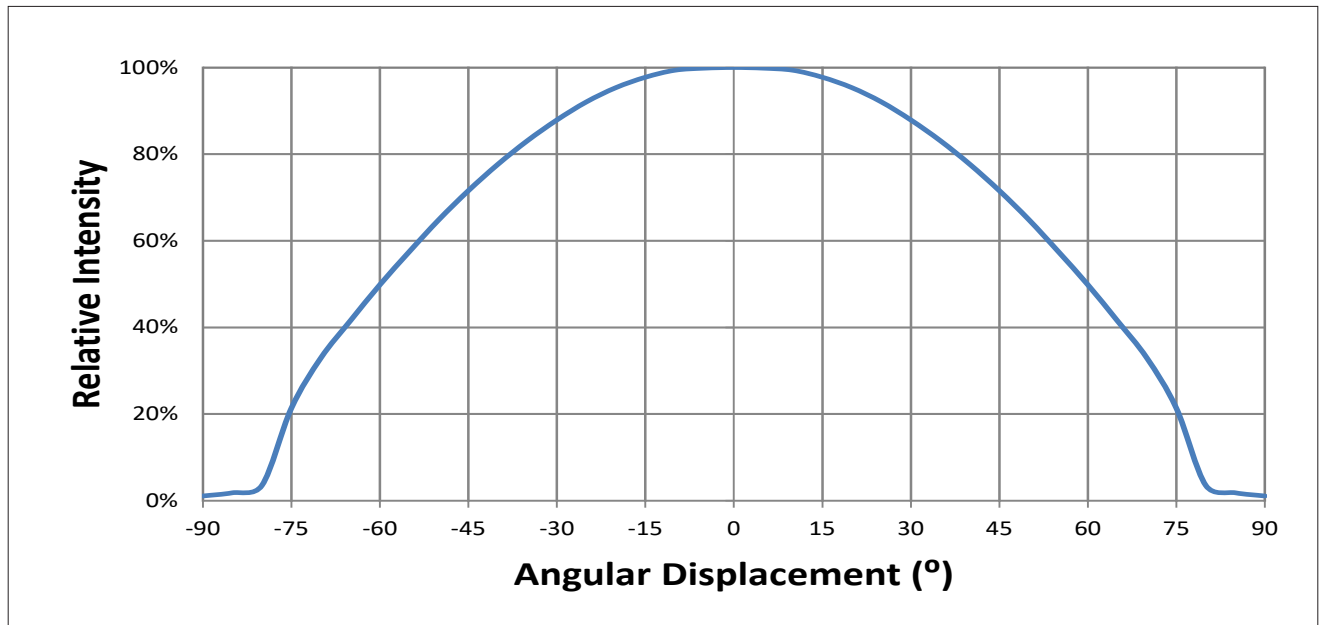

Notes for Figure 8:

1. Typical viewing angle is 120° .
2. The viewing angle is defined as the off axis angle from the centerline where I_v is $\frac{1}{2}$ of the peak value.

Figure 9: Typical Polar Radiation Pattern at 700mA, $T_{sp} = 25^{\circ}\text{C}$

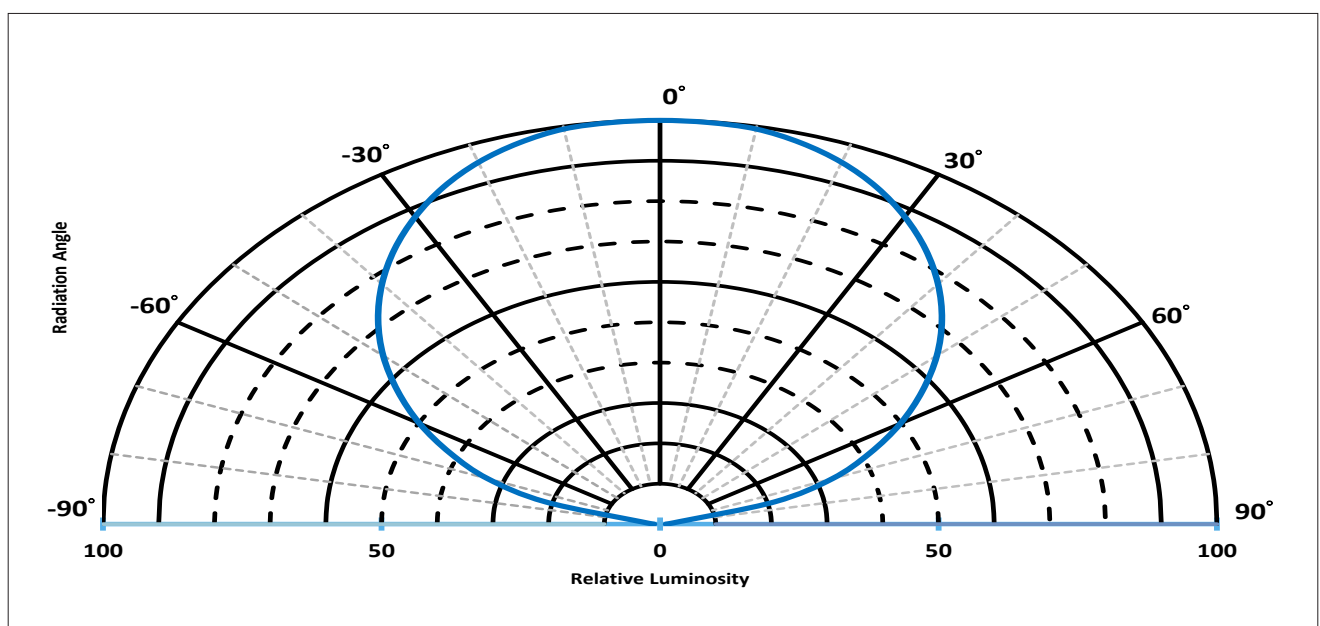

Typical Color Spectrum

Figure 10: Typical Color Spectrum at 700mA, Tsp=85°C

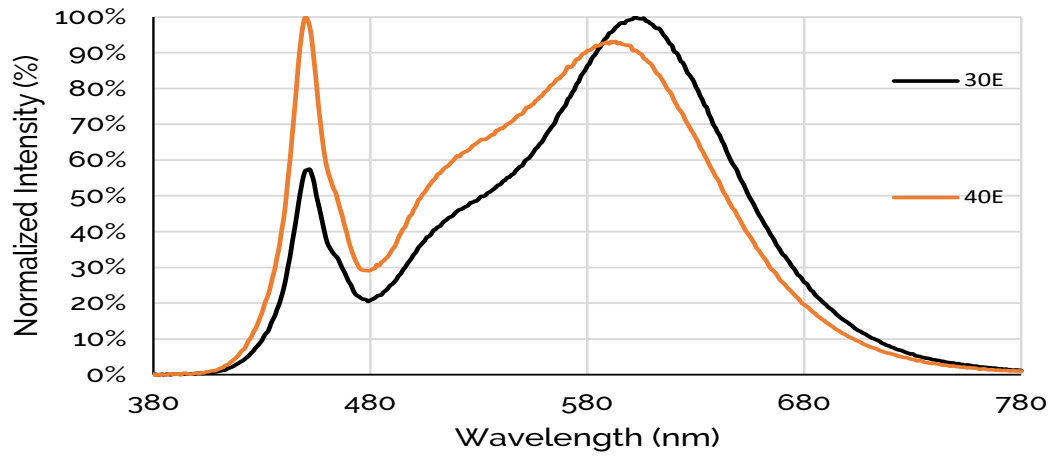

Notes for Figure 10:

1. Color spectra shown for warm white is 3000K and 80 CRI.
2. Color spectra shown for neutral white is 4000K and 80 CRI.

Mechanical Dimensions

Figure 11: Drawing for CSP 2727

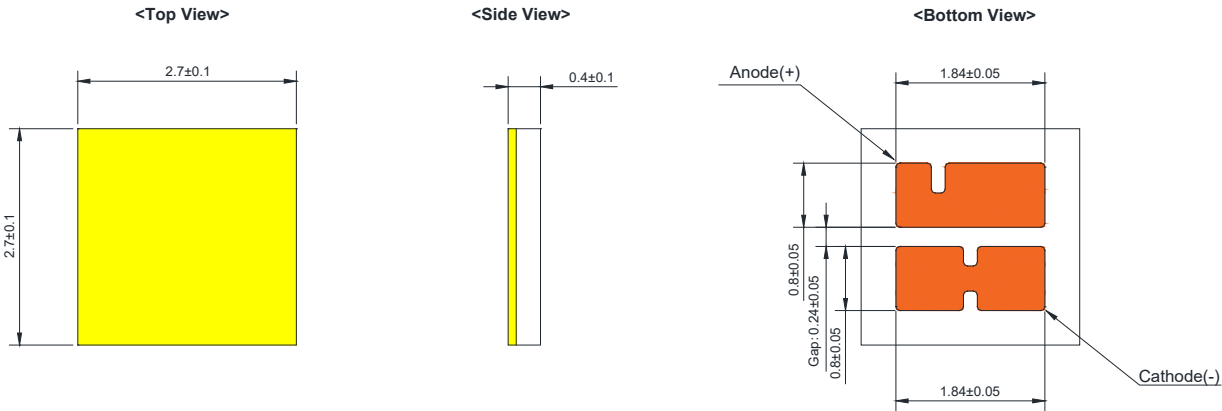

Notes for Figure 11:

1. Drawings are not to scale.
2. Drawing dimensions are in millimeters.
3. Unless otherwise specified, tolerances are ± 0.10 mm.
4. The optical center of the LED emitter is nominally defined by the mechanical center of the emitter. The light emitting surface (LES) is centered on the mechanical center of the LED emitter to a tolerance of ± 0.2 mm

Recommended PCB Soldering Pad Pattern

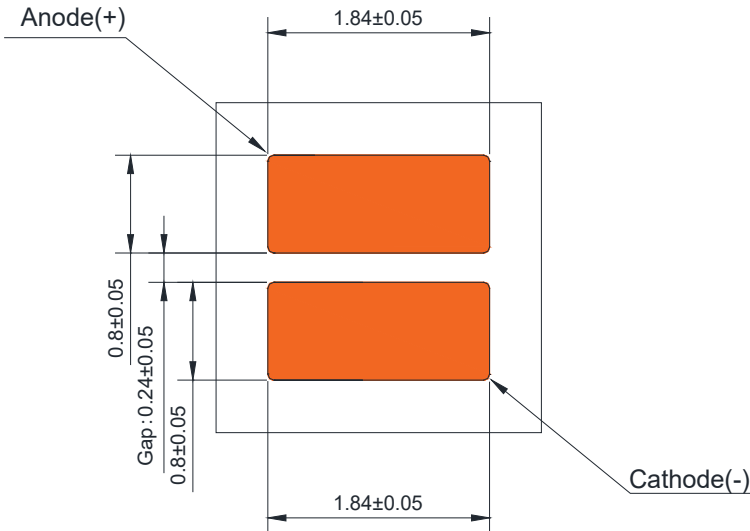

Reliability

Table 9: Reliability Test Items and Conditions

No .	Items	Reference Standard	Test Conditions	Drive Current	Test Duration	Units Failed/Tested
1	Moisture Sensitivity Level	J-STD-020E	$T_{\text{slid}} = 260^{\circ}\text{C}$, 10sec, Precondition: 85°C , 60%RH, 168hr		3 reflows	0/22
2	Low Temperature Storage	JESD22-A119	$T_{\text{a}} = -40^{\circ}\text{C}$		1000 hours	0/22
3	High Temperature Storage	JESD22-A103D	$T_{\text{a}} = 125^{\circ}\text{C}$		1000 hours	0/22
4	Low Temperature Operating Life	JESD22-A108D	$T_{\text{a}} = -40^{\circ}\text{C}$	2000mA	1000 hours	0/22
5	Temperature Humidity Operating Life	JESD22-A101C	$T_{\text{sp}} = 85^{\circ}\text{C}$, RH=85%	2000mA	1000 hours	0/22
6	High Temperature Operating Life	JESD22-A108D	$T_{\text{sp}} = 85^{\circ}\text{C}$	2000mA	1000 hours	0/22
7	Power Switching	IEC62717	$T_{\text{sp}} = 85^{\circ}\text{C}$, ON 30s OFF 30s	2000mA	30000 Cycle	0/22
8	Thermal Shock	JESD22-A106B	$T_{\text{a}} = -40^{\circ}\text{C} \sim 125^{\circ}\text{C}$; Dwell : 15min; Transfer: 10sec		200 Cycle	0/22
9	Electrostatic Discharge	JS-001-2012	HBM, 2KV, 15k Ω , 100pF, Alternately positive or negative			0/22
10	Vibration Test	JESD22-B103	10m/s ² , 100-20000-100Hz 4 cycles,4min,eachX,Y,Z		4 Cycles	0/22

Passing Criteria

Item	Symbol	Test Condition	Passing Criteria
Forward Voltage	Vf	700mA	$\Delta V_f < 10\%$
Luminous Flux	Iv	700mA	$\Delta I_v < 30\%$
Chromaticity Coordinates	(x, y)	700mA	$\Delta u'v' < 0.007$

Notes for Table 9:

1. Test board: Aluminum board thickness -1.0mm, Copper layer thickness-70um.
2. Measurements are performed after allowing the LEDs to return to room temperature
3. T_{slid} : reflow soldering temperature; T_{a} : ambient temperature

Reflowing Characteristics

Figure 12 : Reflow Profile

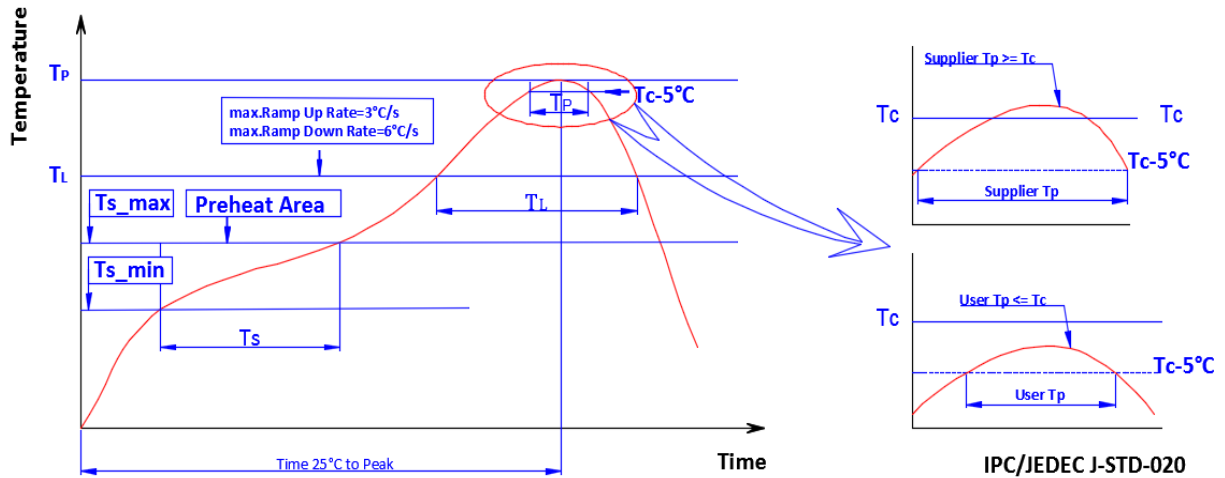

Profile Parameters	Lead-Free Solder SAC305
Average Ramp-Up Rate (T_s_{max} to T_p)	$3^\circ\text{C/second max.}$
Preheat: Temperature Min (T_s_{min})	150°C
Preheat: Temperature Max (T_s_{max})	190°C
Preheat: Time ($t_{s_{\text{min}}}$ to $t_{s_{\text{max}}}$)	90-120 seconds
Liquidous Temperature (T_l)	217°C
Time Maintained Above Liquidous Temperature (T_L): Time (t_l)	60-90 seconds
Peak/Classification Temperature (T_p)	$250\text{-}255^\circ\text{C}$
Time Within 10°C of Actual Peak Temperature (T_p)	20-40 seconds
Ramp-Down Rate	$6^\circ\text{C/second max}$
Time 25°C to Peak Temperature	8 minutes max.

Packaging

Figure 13: Reel Drawings

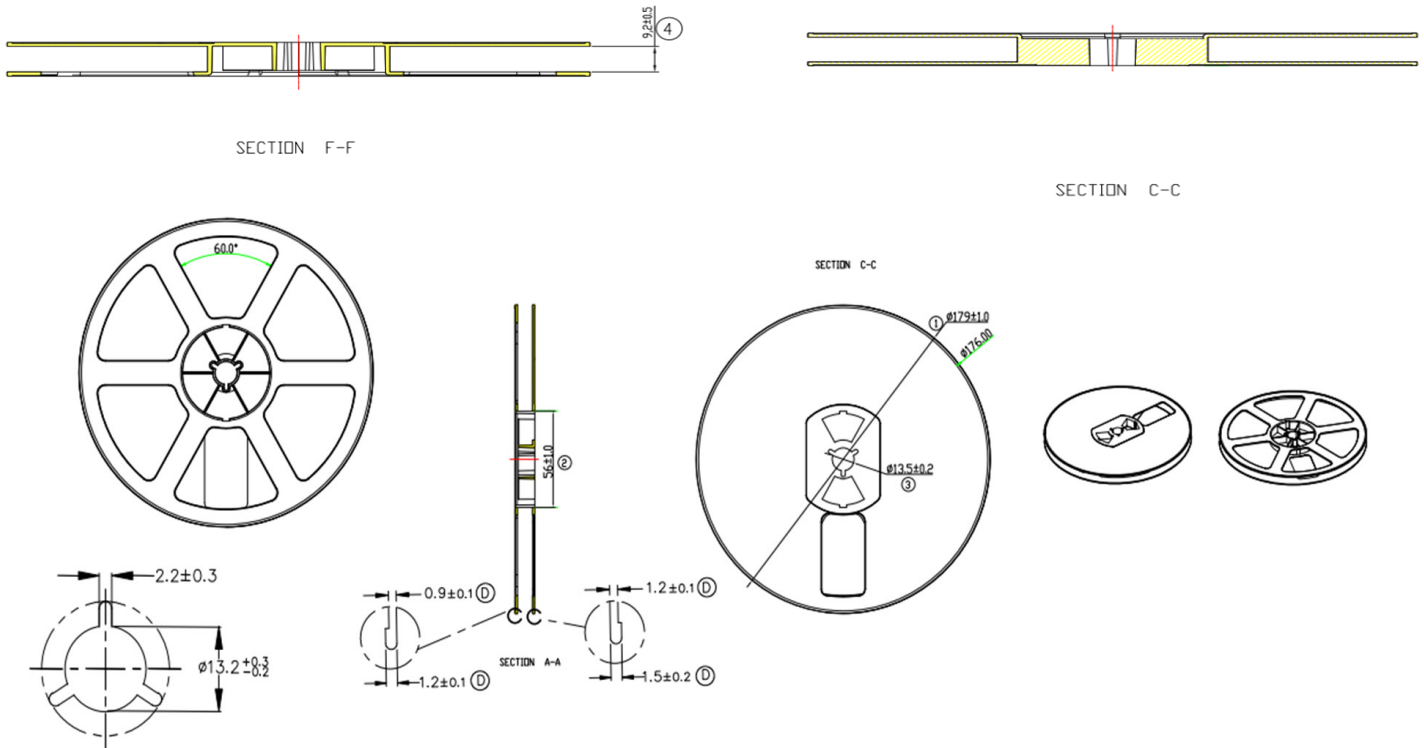

Note for Figure 13:

1. Drawings are not to scale. Drawing dimensions are in millimeters.

Figure 14: Tape Drawings

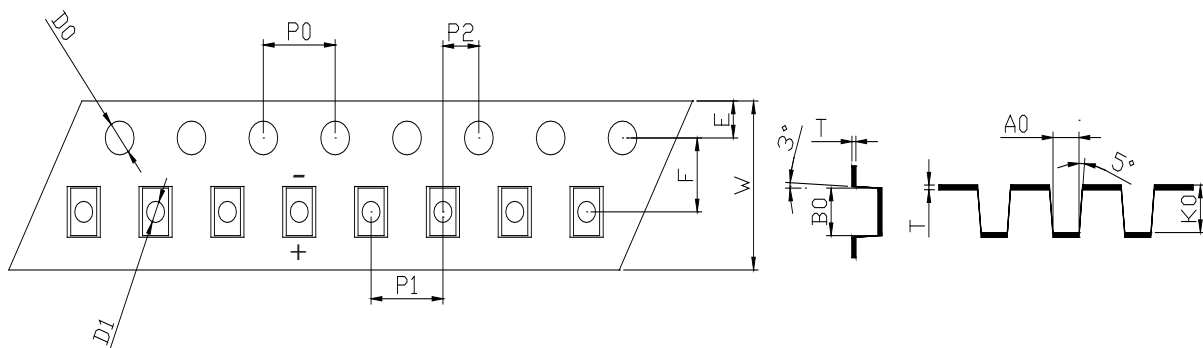

W	T	A0	B0	Ko	D0	D1	E	F	P0	P1	P2	10P0
8.00±0.05	0.20±0.02	3.00±0.10	3.05±0.10	0.60±0.10	1.60±0.10	1.10±0.10	1.75±0.10	3.50±0.10	4.00±0.10	4.00±0.10	2.00±0.10	40.00±0.20

Note for Figure 14:

1. Drawings are not to scale. Drawing dimensions are in millimeters.

Packaging

Figure 15: Reel Packaging Drawings

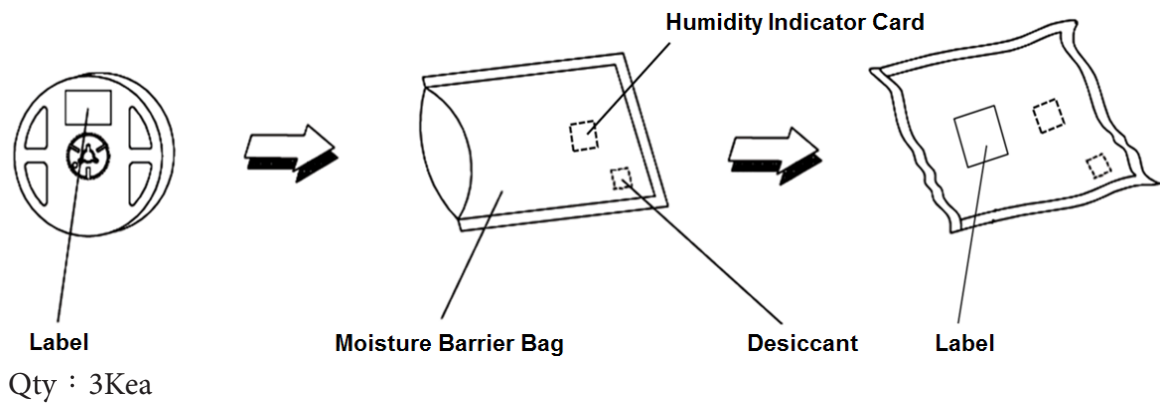

Note for Figure 15:

1. Drawings are not to scale.
2. LED Quantity of each reel is not less than labeling.
3. Empty cavity of reel is not more than 5ea, continuous empty cavity is not more than 2ea.

Design Resources

Optical Source Models

Please contact your Bridgelux sales representative for assistance.

Precautions

CAUTION: CHEMICAL EXPOSURE HAZARD

Exposure to some chemicals commonly used in luminaire manufacturing and assembly can cause damage to the CSP.

CAUTION: EYE SAFETY

Eye safety classification for the use of Bridgelux CSP is in accordance with IEC specification 62471: Photobiological Safety of Lamps and Lamp Systems. Most Bridgelux CSPs are classified as Risk Group Exempt or Risk Group 1 in accordance with IEC specification 62471. However, the CSP LEDs will be classified as Risk Group 2 when operated at high power conditions with high ratio blue wavelength in the emission spectrum depending on characteristics. Please use appropriate precautions. It is important that employees working with LEDs are trained to use them safely.

CAUTION: RISK OF BURN

Do not touch the CSP LES during operation. Allow the CSP to cool for a sufficient period of time before handling. The CSP may reach elevated temperatures such that could burn skin when touched.

CAUTION: PICK AND PLACE

Recommend using Teflon material for nozzle. Sharp steel material must not be used as pick up tools.

CAUTION

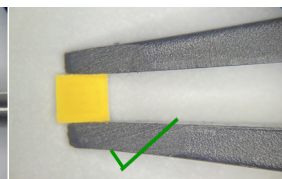
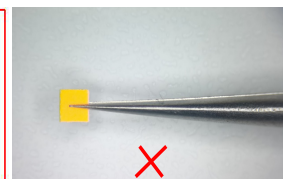
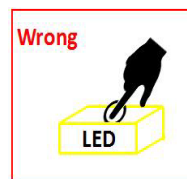

Disclaimers

MINOR PRODUCT CHANGE POLICY

The rigorous qualification testing on products offered by Bridgelux provides performance assurance. Slight cosmetic changes that do not affect form, fit, or function may occur as Bridgelux continues product optimization.

STANDARD TEST CONDITIONS

Unless otherwise stated, LED emitter testing is performed at the nominal drive current.

About Bridgelux: Bridging Light and Life™

At Bridgelux, we help companies, industries and people experience the power and possibility of light. Since 2002, we've designed LED solutions that are high performing, energy efficient, cost effective and easy to integrate. Our focus is on light's impact on human behavior, delivering products that create better environments, experiences and returns—both experiential and financial. And our patented technology drives new platforms for commercial and industrial luminaires.

For more information about the company, please visit
bridgelux.com
twitter.com/Bridgelux
facebook.com/Bridgelux
WeChat ID: BridgeluxInChina



46410 Fremont Boulevard
Fremont, CA 94538 U.S.A.
Tel (925) 583-8400
www.bridgelux.com

© 2025 Bridgelux, Inc. All rights reserved. Product specifications are subject to change without notice. Bridgelux and the Bridgelux stylized logo design are registered trademarks of Bridgelux, Inc. All other trademarks are the property of their respective owners.

Bridgelux CSP 2727 Product Data Sheet DS967 Rev. C (12/2025)