

Bridgelux® Vesta® Series RGBW Gen2 10mm Array With CSP

Product Data Sheet DS591



Product Feature Map

Bridgelux arrays are fully engineered devices that provide consistent thermal and optical performance on an engineered mechanical platform. The arrays incorporate several features to simplify design integration and assembly. Please visit www.bridgelux.com for more information on the Vesta Series family of products.

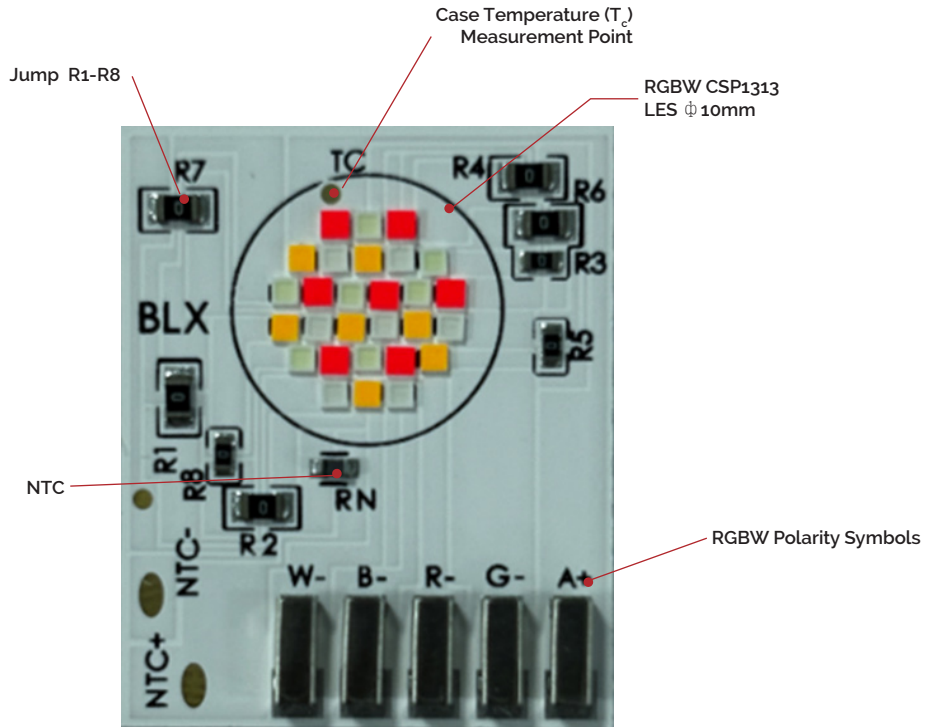

Product Nomenclature

The part number designation for Bridgelux Vesta Series arrays is explained as follows:

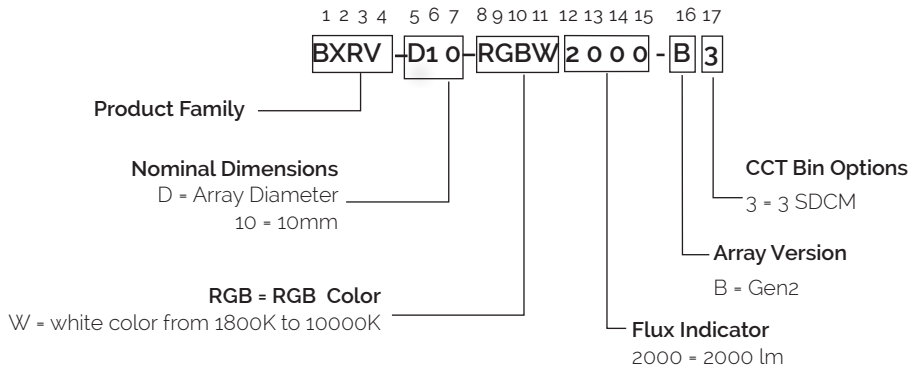

Product Selection Guide

The following product configurations are available:

Table 1: Selection Guide, RGB Channels Measurement Data (T_j=T_c=25°C)

Part Number	Channel	Typical Drive Current ¹ (mA)	Dominant Wavelength(nM)			Peak Wavelength(nM)			Forward Voltage ¹ (V)			Purity	Typical Pulsed Flux ^{2,3} T _c =25°C ⁴ (lm)	Typical Power T _c =25°C ⁴ (W)
			Min	Typical	Max	Min	Typical	Max	Min	Typical	Max			
BXRV-D10-RGBW2000-B3	Red	300	610	616	623	625	632	640	18.6	19.7	20.9	0.949	271	5.9
	Green	350	515	521	530	505	514	520	18.2	19.3	20.5	0.783	1014	6.8
	Blue	350	455	/	460	450	/	456	19.6	20.9	22.1	0.975	171	7.3

Table 2: Selection Guide, W Channel Measurement Data (T_j=T_c=25°C)

Part Number	Channel	Typical Drive Current ¹ (mA)	Forward Voltage ¹ (V)			Typical Pulsed Flux ^{2,3} T _c =25°C ⁴ (lm)	Typical Power T _c =25°C ⁴ (W)	Typical Efficacy T _c =25°C ⁴ (lm/W)
			Min	Typical	Max			
BXRV-D10-RGBW2000-B3	White	350	19.6	20.8	22.1	1055	7.3	145

Notes for Table 1 and 2:

1. Products tested under pulsed condition (10ms pulse width) at nominal drive current where T_j (junction temperature) - T_c (case temperature) - 25°C.
2. Typical performance values are provided as a reference only and are not a guarantee of performance.
3. Bridgelux maintains a ±7% tolerance on flux measurements.
4. Typical performance is estimated based on operation under pulsed condition (10ms pulse width) with LED array mounted onto a heat sink with thermal interface material and the case temperature maintained at 25°C. Based on Bridgelux test setup, values may vary depending on the thermal design of the luminaire and/or the exposed environment to which the product is subjected.

Product Selection Guide

The following product configurations are available:

Table 3: Selection Guide, RGB Channels Measurement Data (T_j=T_c=65°C)

Part Number	Channel	Typical Drive Current ¹ (mA)	Dominant Wavelength(nM)			Peak Wavelength(nM)			Forward Voltage ¹ (V)			Purity	Typical Pulsed Flux ^{2,3} T _c =65°C ⁴ (lm)	Typical Power T _c =65°C ⁴ (W)
			Min	Typical	Max	Min	Typical	Max	Min	Typical	Max			
BXRV-D10-RGBW2000-B3	Red	300	610	615	623	625	632	640	18.1	19.2	20.4	0.941	230	5.8
	Green	350	515	524	533	505	518	523	17.2	18.3	19.4	0.768	933	6.4
	Blue	350	455	/	462	450	/	458	19.0	20.2	21.4	0.971	175	7.1

Table 4: Selection Guide, W Channel Measurement Data (T_j=T_c=65°C)

Part Number	Channel	Typical Drive Current ¹ (mA)	Forward Voltage ¹ (V)			Typical Pulsed Flux ^{2,3} T _c =65°C ⁴ (lm)	Typical Power T _c =65°C ⁴ (W)	Typical Efficacy T _c =65°C ⁴ (lm/W)
			Min	Typical	Max			
BXRV-D10-RGBW2000-B3	White	350	18.9	20.1	21.3	975	7.0	139

Notes for Table 3 and 4:

1. Products tested under pulsed condition (10ms pulse width) at nominal drive current where T_j (junction temperature) - T_c (case temperature) - 65°C.
2. Typical performance values are provided as a reference only and are not a guarantee of performance.
3. Bridgelux maintains a ±7% tolerance on flux measurements.
4. Typical performance is estimated based on operation under pulsed condition (10ms pulse width) with LED array mounted onto a heat sink with thermal interface material and the case temperature maintained at 65°C. Based on Bridgelux test setup, values may vary depending on the thermal design of the luminaire and/or the exposed environment to which the product is subjected.

European Product Registry for Energy Labeling

The European Product Registry for Energy Labeling (EPREL) is defined in the EU Regulation 2017/1369 to provide information about a product's energy efficiency to consumers. Together with Energy Labeling Regulation ELR (EU) 2019/2015, which was amended by regulation (EU) 2021/340 for energy labelling of light sources, manufacturers are required to declare an energy class based on key technical specifications from each of their product and register it in an open data base managed by EPREL. It is now a legal requirement for a vendor of light sources to upload information about their products into the EPREL database before placing these products on the market in the EU.

Table 5 provides a list of part numbers that are in compliance with EPREL regulations and are currently listed in the EPREL database.

At Bridgelux, we are fully committed to supplying products that are compliant with pertinent laws, rules, and obligation imposed by relevant government bodies including the ELR regulation. Customers can use these products with full confidence for any projects that fall under the EPREL requirement.

Table 5: Table of products registered in the European Product Registry for Energy Labeling (EPREL)

Part Number	CCT (K)	CRI	Current ³ (mA)	Voltage ³ (V)	Useful Flux ² Φ_{useful} Tc=85°C (lm)	Power (W)	Efficacy (lm/W)	Energy Efficiency class ⁴ 	Registration No	URL ¹

Notes for Table 5:

1. The performance data in this table is a subset of the data that was submitted to EPREL for obtaining the energy class listed here. For accessing a complete set of technical documentation of Bridgelux registered products in the EPREL database, please visit one of the hyperlinks listed above.
2. For a definition of useful luminous flux (Φ_{useful}), please see the ELR regulations at <https://tinyurl.com/4b6zvt4m>.
3. For information on performance values at alternative drive conditions, please refer to the Product Selection Guide, Absolute Maximum Rating Table and Performance Curves in this data sheet.
4. EPREL requires a symbol for displaying the energy classification of a product in marketing literature. This symbol consists of a letter stating a product's energy efficiency class inside a specific arrow logo as defined by EPREL.
5. All products listed here must be disposed as e-waste according to the guidelines in the country in which the product is used.

Performance at Different CCTs

Table 6: Selection Guide, White Pulsed Measurement Data (T_J=T_C=25°C)

Part Number	Nominal CCT ¹ (K)	CRI ²	Nominal Drive Current ³ Per Channel (mA)				Forward Voltage ³ (V)				Typical Pulsed Flux ^{3,4} T _c =25°C (lm)	Typical Power T _c =25°C (W)	Typical Efficacy T _c =25°C (lm/W)
			Blue	Green	Red	White	Blue	Green	Red	White			
BXRV-D10-RGBW2000-B3	1800K	92	0	2	300	137	18.2	18.2	19.7	19.1	717	9	84
	2200K	95	5	0	300	310	18.2	18.2	19.7	19.8	1169	12	96
	2400K	96	10	7	286	367	18.3	18.3	19.7	20.0	1368	13	103
	2700K	96	18	20	238	395	18.3	18.4	19.5	20.0	1436	13	109
	3000K	96	27	33	198	412	18.4	18.5	19.3	20.1	1523	13	115
	3500K	96	42	55	159	414	18.5	18.6	19.1	20.1	1598	13	122
	4000K	96	57	69	134	410	18.6	18.7	19.0	20.1	1627	13	124
	5000K	96	79	103	87	401	18.7	18.9	18.7	20.0	1679	13	128
	5700K	95	95	112	69	393	18.8	18.9	18.6	20.0	1690	13	129
	6500K	95	110	125	51	385	18.9	19.0	18.5	20.0	1662	13	127
	8000K	94	135	141	44	350	19.0	19.1	18.5	19.9	1662	13	127
	10000K	93	154	151	34	330	19.1	19.2	18.4	19.9	1637	13	126

Notes for Table 6:

1. Nominal CCT as defined by ANSI C78.377-2011.
2. Listed CRIs are typical values and include test tolerance.
3. Typical performance is estimated based on operation under pulsed condition (10ms pulse width) with LED array mounted onto a heat sink with thermal interface material and the case temperature maintained at 25°C. Based on Bridgelux test setup, values may vary depending on the thermal design of the luminaire and/or the exposed environment to which the product is subjected.
4. Bridgelux maintains a ±7% tolerance on flux measurements.

Performance at Different CCTs

Table 7: Selection Guide, White Pulsed Measurement Data (T_J=T_C=65°C)

Part Number	Nominal CCT ¹ (K)	CRI ²	Nominal Drive Current ³ Per Channel (mA)				Forward Voltage ³ (V)				Typical Pulsed Flux ^{3,4} T _c =65°C ⁷ (lm)	Typical Power T _c =65°C (W)	Typical Efficacy T _c =65°C (lm/W)
			Blue	Green	Red	White	Blue	Green	Red	White			
BXRV-D10-RGBW2000-B3	1800K	91	0	2	300	137	17.9	17.9	19.4	18.7	677	8.4	80
	2200K	94	5	0	300	310	17.9	17.9	19.4	19.4	1095	11.9	92
	2400K	95	10	7	286	367	18.0	17.9	19.4	19.6	1283	13.0	98
	2700K	95	18	20	238	395	18.0	18.0	19.2	19.7	1348	13.0	104
	3000K	96	27	33	198	412	18.1	18.1	19.0	19.7	1430	13.0	110
	3500K	96	42	55	159	414	18.2	18.2	18.8	19.7	1505	12.9	117
	4000K	96	57	69	134	410	18.3	18.3	18.7	19.7	1536	12.9	119
	5000K	95	79	103	87	401	18.4	18.5	18.4	19.7	1588	12.8	124
	5700K	95	95	112	69	393	18.5	18.6	18.3	19.7	1591	12.8	124
	6500K	95	110	125	51	385	18.6	18.7	18.2	19.6	1574	12.8	123
	8000K	94	135	141	44	350	18.7	18.7	18.2	19.6	1573	12.8	123
	10000K	94	154	151	34	330	18.8	18.8	18.1	19.5	1553	12.8	121

Notes for Table 7:

1. Nominal CCT as defined by ANSI C78.377-2011.
2. Listed CRIs are typical values and include test tolerance.
3. Typical performance is estimated based on operation under pulsed condition (10ms pulse width) with LED array mounted onto a heat sink with thermal interface material and the case temperature maintained at 65°C. Based on Bridgelux test setup, values may vary depending on the thermal design of the luminaire and/or the exposed environment to which the product is subjected.
4. Bridgelux maintains a ±7% tolerance on flux measurements.

Performance at Commonly Used Drive Currents

Table 8: RGBW Performance at Commonly Used Drive Currents

Part Number	Channel	CRI	Drive Current (mA)	Typical Vf Tc = 25°C (V)	Typical Power Tc = 25°C(W)	Typical Flux ¹ Tc = 25°C(lm)	Typical Pulsed Flux ² Tc = 65°C(lm)	Typical Efficacy Tsp = 25°C (lm/W)
EXRV-D10-RGBW2000-B3	White	70	50	18.8	0.9	176	174	186
			150	19.6	2.9	502	478	171
			200	19.9	4.0	652	616	164
			300	20.5	6.2	928	865	151
			350	20.8	7.3	1055	975	145
			450	21.3	9.6	1291	1166	135
			500	21.6	10.8	1401	1248	130
	Red	/	50	18.5	0.9	55	53	60
			100	18.9	1.9	106	99	56
			150	19.1	2.9	152	141	53
			200	19.4	3.9	194	177	50
			250	19.6	4.9	234	207	48
			300	19.7	5.9	271	230	46
	Green	/	50	16.5	0.8	203	196	247
			150	17.6	2.6	529	503	200
			200	18.1	3.6	669	632	185
			300	18.9	5.7	910	845	160
			350	19.3	6.8	1014	933	150
			450	20.0	9.0	1195	1079	133
			500	20.3	10.1	1275	1140	126
	Blue	/	50	18.6	0.9	30	31	32
			150	19.5	2.9	82	85	28
			200	19.9	4.0	106	109	27
			300	20.6	6.2	150	154	24
			350	20.9	7.3	171	175	23
			450	21.5	9.7	209	212	22
			500	21.7	10.9	227	229	21

Notes for Table 8:

1. Bridgelux maintains a ± 7% tolerance on flux measurements.
2. Alternate drive currents in Table 6 are provided for reference only and are not a guarantee of performance.
3. Please refer to Table g for maximum current ratings for each color.

Absolute Maximum Ratings

Table 9: Maximum Ratings

Parameter	Maximum Rating			
LED Junction Temperature (Tj)	135°C			
Storage Temperature	-40°C to 85°C			
Operating Case Temperature (Tc) ¹ For Red Channel And Tunable White With 4 Channels	85°C			
Operating Case Temperature (Tc) ² For White/Green/ Blue Channels	105°C			
Soldering Temperature	350°C or lower for a maximum of 5 seconds			
Channel	White	Red	Green	Blue
Max Drive Current ¹	500mA	300mA	500mA	500mA
Max Peak Pulsed Drive Current ²	700mA	420mA	700mA	700mA
Max Drive Current ¹ For Tunable White With 4 Channels	670mA			
Max Reverse Voltage	-35 V			

Notes for Table 9:

1. Refer to the Derating Curves for Current vs Case Temperature. Figures 8, 9 and 10.
2. Bridgelux recommends a maximum duty cycle of 10% and pulse width of 20ms when operating LED arrays at the maximum peak pulsed current specified. Maximum peak pulsed currents indicate values where the LED array can be driven without catastrophic failures.

Table 10: Current Ratio for Tunable White with BBL

CCT Color	1800K	2200K	2400K	2700K	3000K	3500K	4000K	5000K	5700K	6500K	8000K	10000K
B	0.00%	0.81%	1.48%	2.66%	4.02%	6.26%	8.45%	11.82%	14.25%	16.36%	20.20%	23.06%
G	0.46%	0.00%	1.03%	2.95%	4.89%	8.20%	10.30%	15.36%	16.78%	18.65%	21.01%	22.55%
R	68.34%	48.78%	42.69%	35.45%	29.62%	23.70%	20.01%	13.00%	10.32%	7.55%	6.52%	5.07%
W	31.21%	50.41%	54.80%	58.94%	61.47%	61.85%	61.23%	59.82%	58.65%	57.44%	52.26%	49.32%
Total	100.00%	100.00%	100.00%	100.00%	100.00%	100.00%	100.00%	100.00%	100.00%	100.00%	100.00%	100.00%

Notes for Table 10:

1. Please refer to Table 7 for maximum current ratings for each color.

Tunable White with BBL Color Range

Figure 1: Chromaticity Coordinate Group (Color Targeted at $T_{sp}=65^{\circ}\text{C}$)

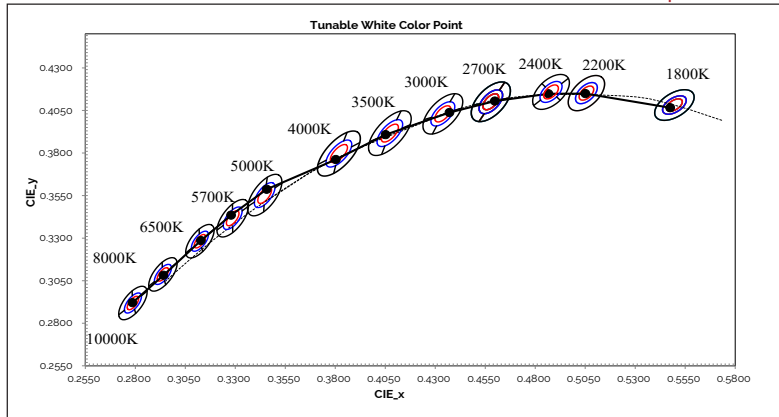

Table 11: Tunable White with BBL MacAdam Ellipse Color Bin Definitions ($T_c=65^{\circ}\text{C}$)

Channel	Color Space	Center Point		Major Axis	Minor Axis	θ' (angle)	Color Bin
		x	y				
1800K	3	0.5496	0.4082	0.00698	0.00393	40.000	3
	5						5
2200K	3	0.5056	0.4152	0.00723	0.00399	51.918	3
	5						5
2400K	3	0.4879	0.4159	0.00723	0.00399	51.000	3
	5						5(E/F/G/H)
2700K	3	0.4578	0.4101	0.00810	0.00420	53.700	3
	5						5(E/F/G/H)
3000K	3	0.4338	0.4030	0.00834	0.00408	53.220	3
	5						5(E/F/G/H)
3500K	3	0.4073	0.3917	0.00927	0.00414	54.000	3
	5						5(E/F/G/H)
4000K	3	0.3818	0.3797	0.00939	0.00402	53.720	3
	5						5(E/F/G/H)
5000K	3	0.3447	0.3553	0.00822	0.00354	59.620	3
	5						5(E/F/G/H)
5700K	3	0.3287	0.3417	0.00746	0.00320	59.090	3
	5						5(E/F/G/H)
6500K	3	0.3123	0.3282	0.00669	0.00285	58.570	3
	5						5(E/F/G/H)
8000K	3	0.2938	0.3087	0.00669	0.00285	58.570	3
	5						5(E/F/G/H)
10000K	3	0.2788	0.2919	0.00669	0.00285	58.570	3
	5						5(E/F/G/H)

Performance Curves

Figure 2: Forward Voltage vs. Forward Current, $T_c = 25^\circ\text{C}$

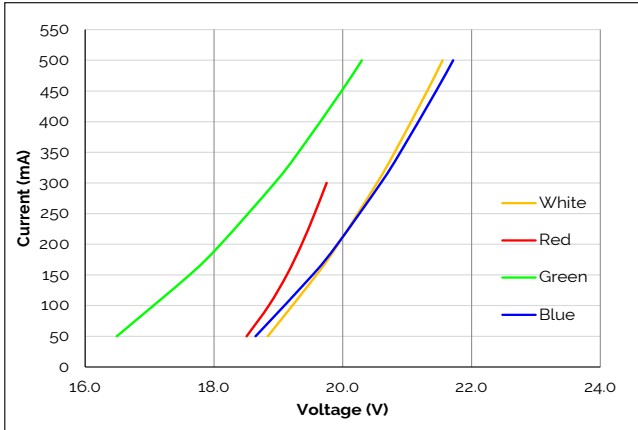

Figure 3: Relative Flux vs. Drive Current, $T_c = 25^\circ\text{C}$

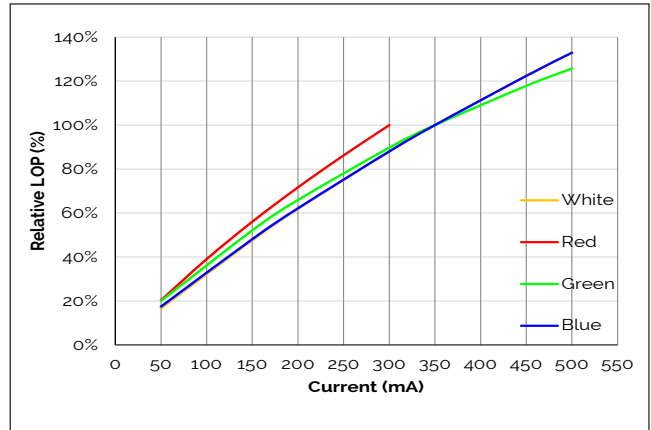

Figure 4: Relative Flux vs. Case Temperature

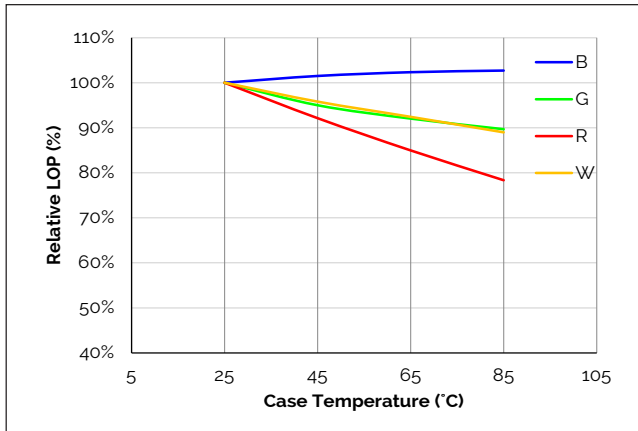

Figure 5: Relative Voltage vs. Case Temperature

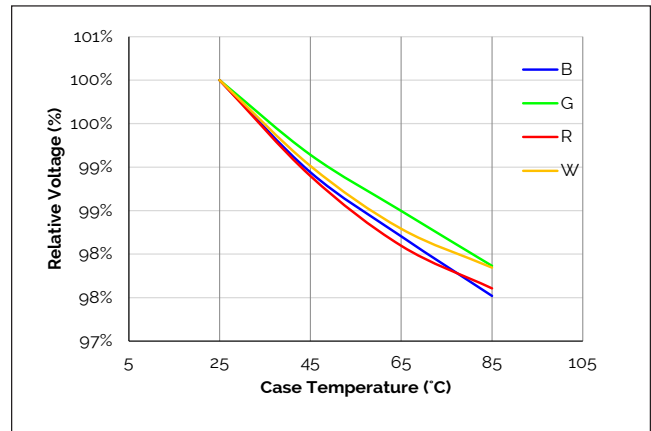

Figure 6: Current Ratio vs. CCT

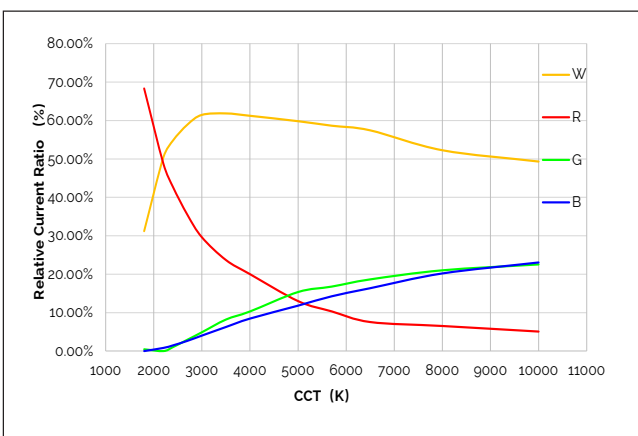
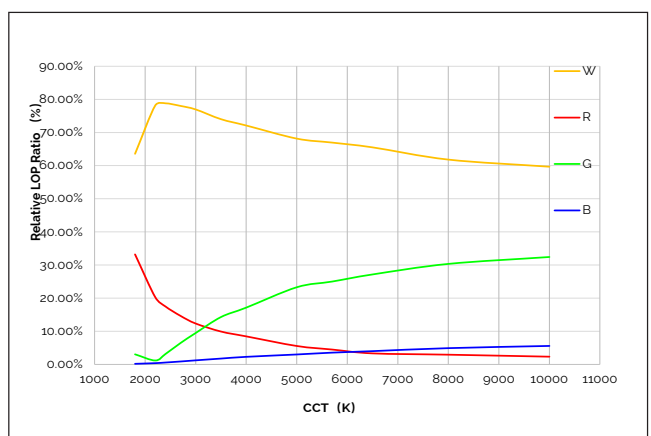

Figure 7: Relative Flux vs. CCT



Performance Curves

Figure 8: Derating Curve for Tunable White with 4 Channels

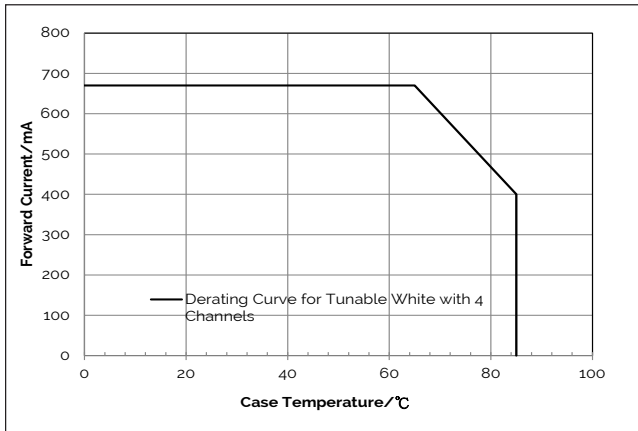

Figure 9: Derating Curve for Red Channel

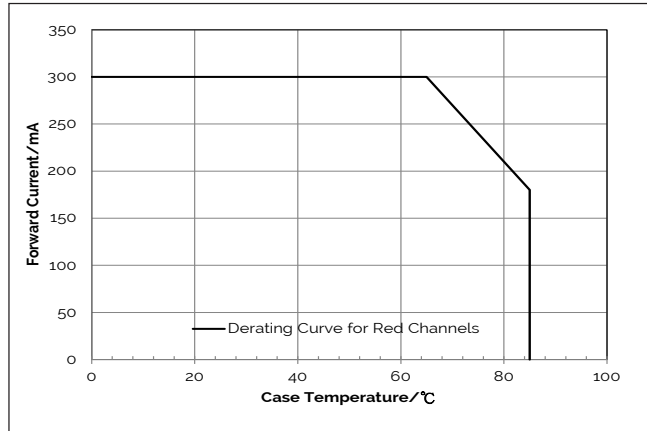
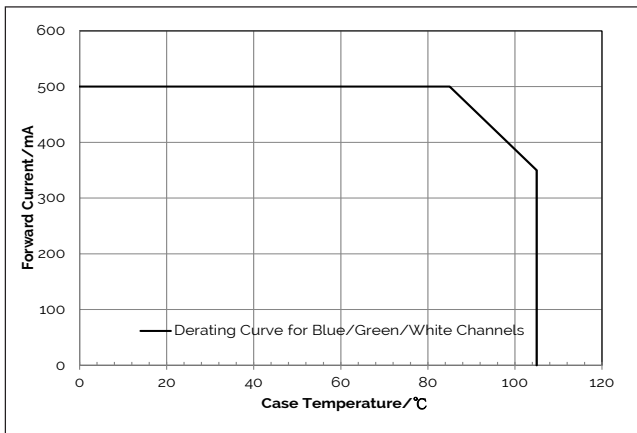
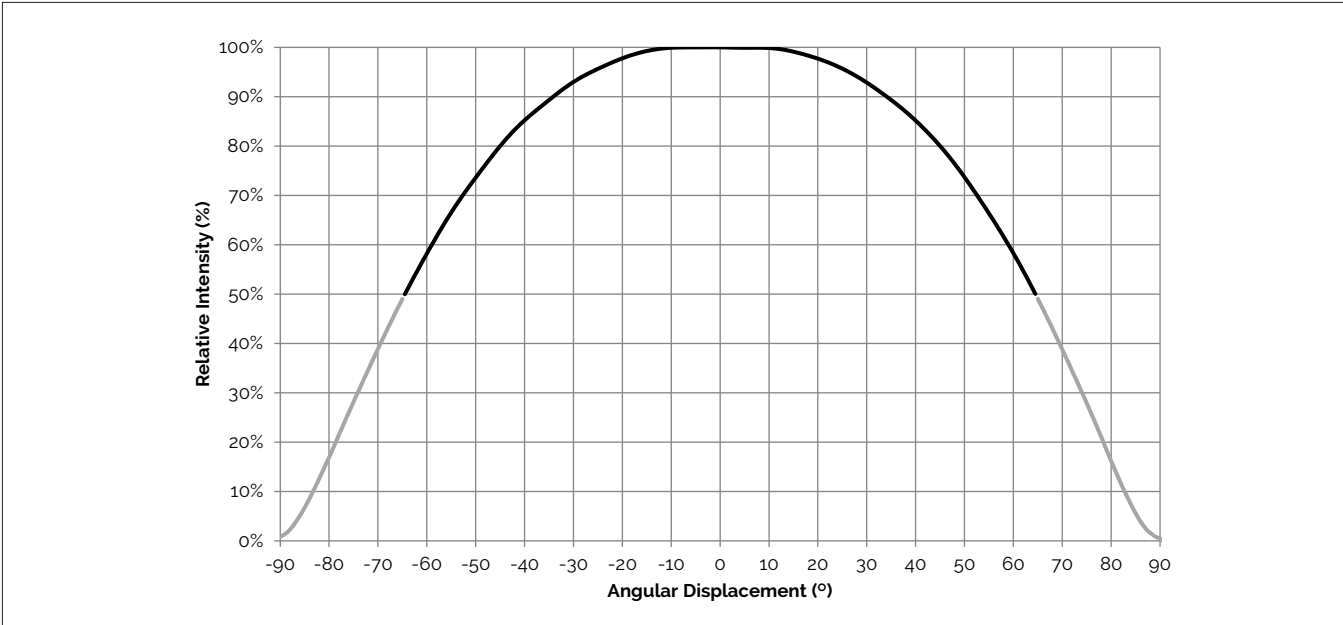

Figure 10: Derating Curve for Blue/Green/White Channels



Typical Radiation Pattern

Figure 11: Typical Spatial Radiation Pattern



Notes for Figure 11:

- 1. Typical viewing angle is 130°.
- 2. The viewing angle is defined as the off axis angle from the centerline where Iv is 1/2 of the peak value.

Figure 12: Typical Polar Radiation Pattern

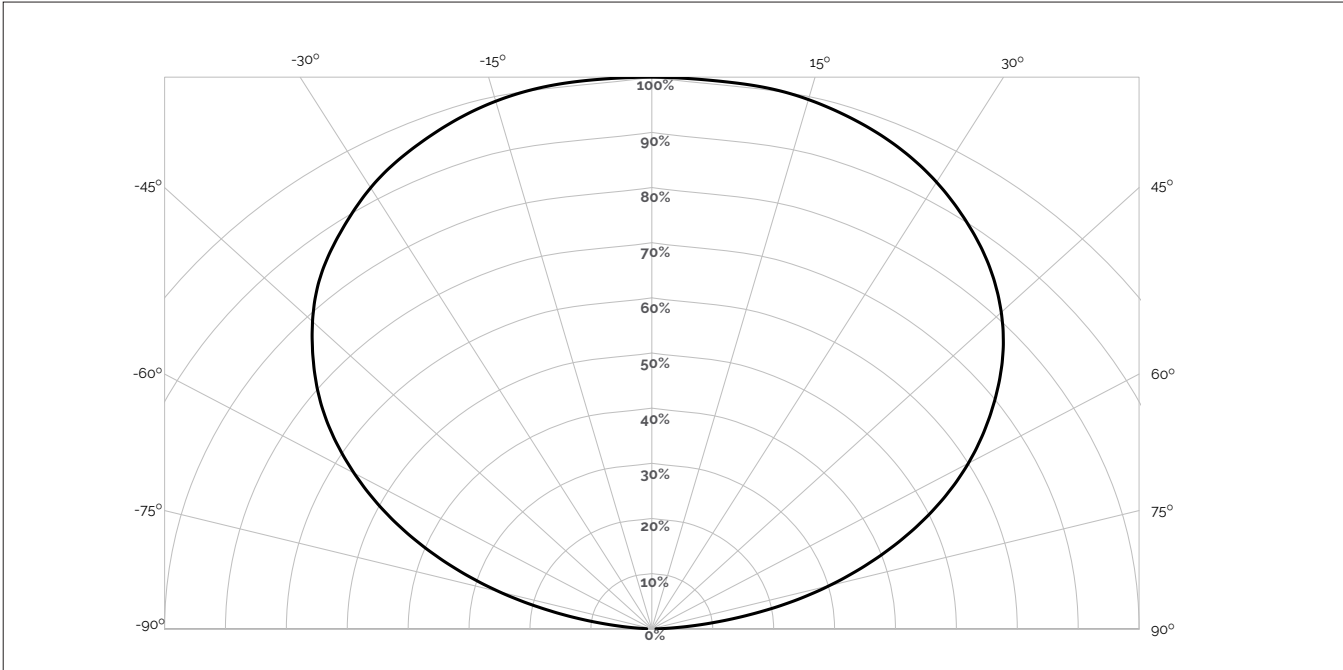

Typical Color Spectrum

Figure 13: Spectrum from 1800K - 10000K

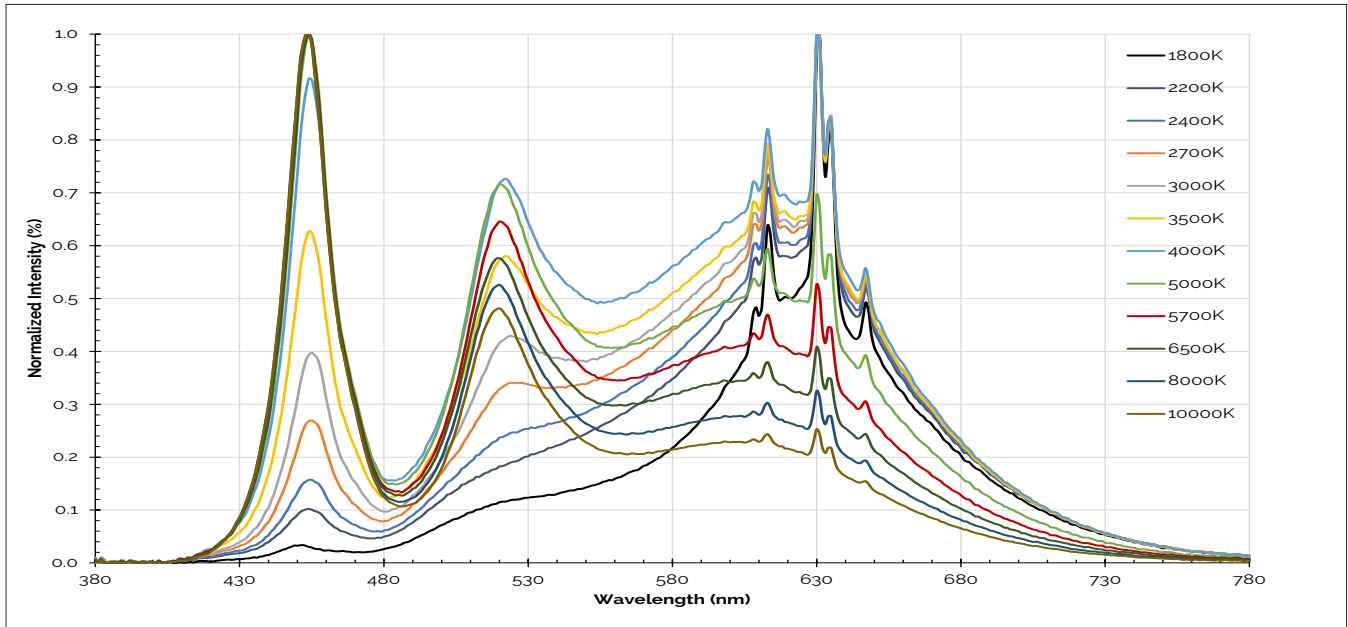

Note for Figure 13:

1. Color spectra measured at nominal current for $T_j = T_c = 65^\circ\text{C}$.
2. Please refer to Table 4 and 5 for typical CRI at each CCT.

Figure 14 Typical Color Spectrum (RGBW)

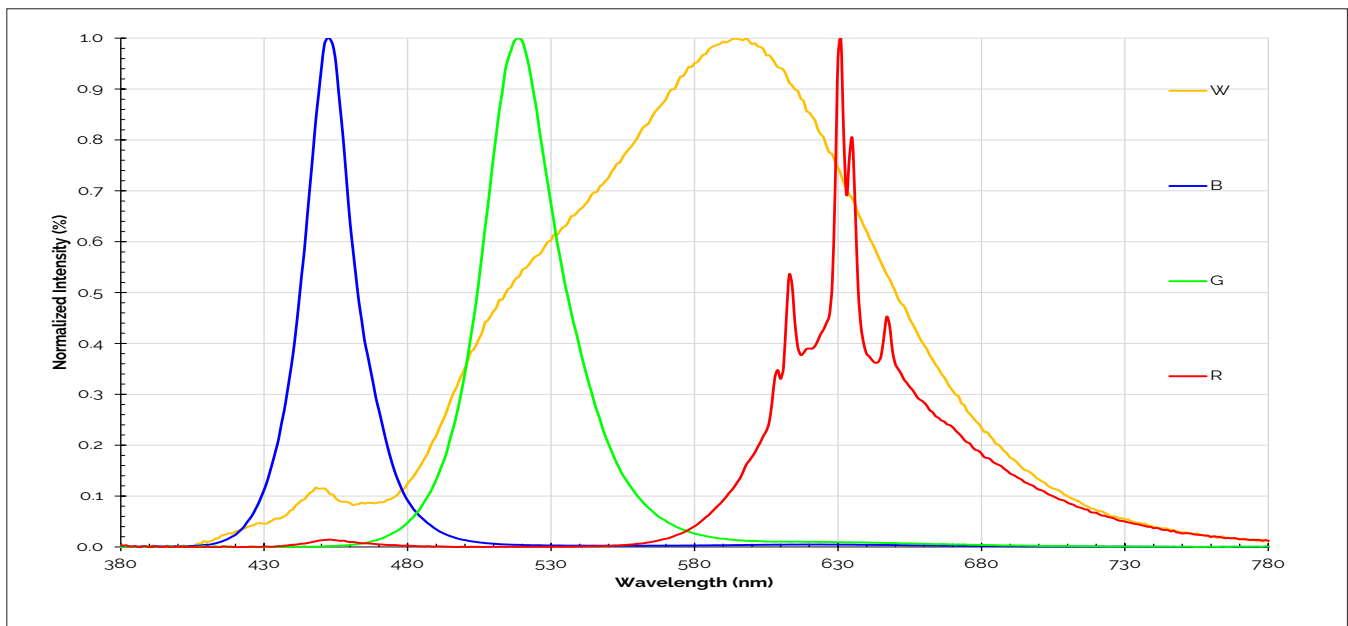

Note for Figure 14:

1. Color spectra measured at nominal current for $T_j = T_c = 65^\circ\text{C}$.

Color Binning Information

Table 12: RW MacAdam Ellipse Color Bin Definitions

Channel	Center Point		Major Axis	Minor Axis	θ' (angle)	Color Bin
	x	y				
R	0.6692	0.3158	0.01854	0.00828	160.00	1
W	0.4634	0.4730	0.00834	0.00408	53.22	3

Table 13: BG Color Bin Definitions

Channel		1	2	3	4
B	X	0.1566	0.1355	0.1494	0.1706
	Y	0.0177	0.0399	0.0648	0.0415
G	X	0.1050	0.1050	0.2000	0.2000
	Y	0.7000	0.7500	0.7500	0.7000

Notes for Table 12 and 13:

1. Color binning at Tc- 65°C unless otherwise specified
2. Bridgelux maintains a tolerance of ± 0.007 on x and y color coordinates.

Figure 15: Definition of the McAdam ellipse

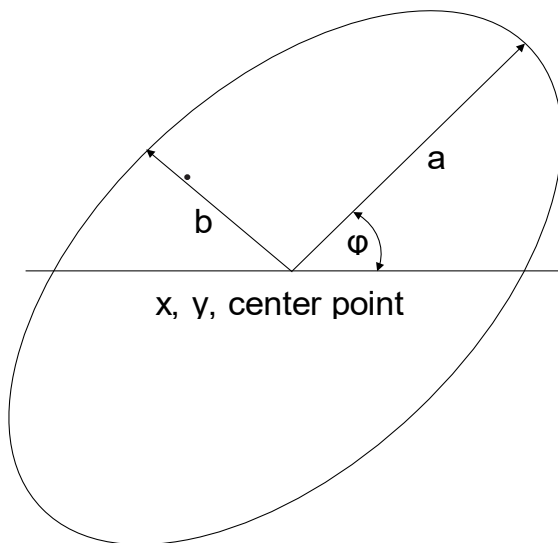

Color Binning Information

Figure 16: Chromaticity Coordinate Group (Color Bin Structure, Color Targeted at Tc=65°C)

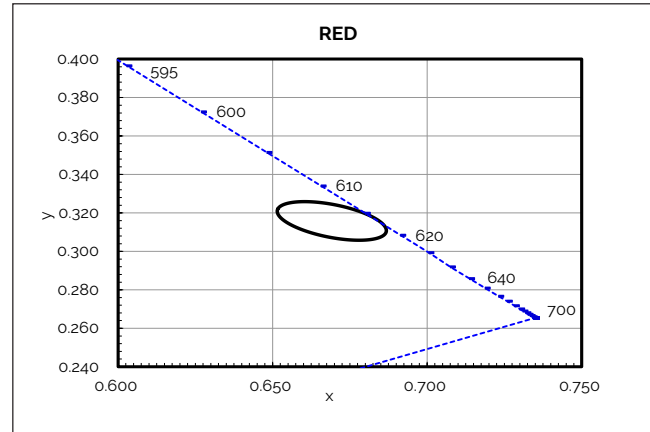
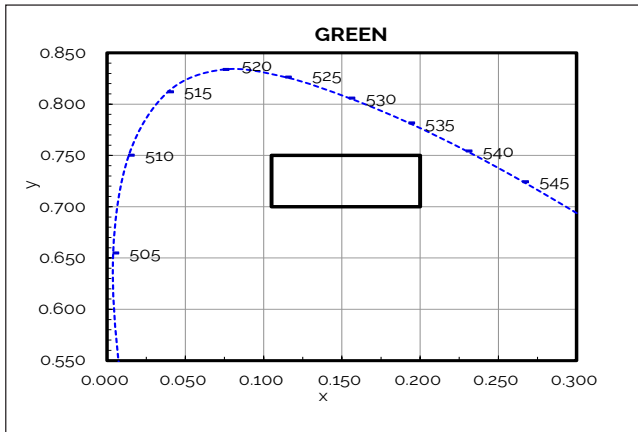
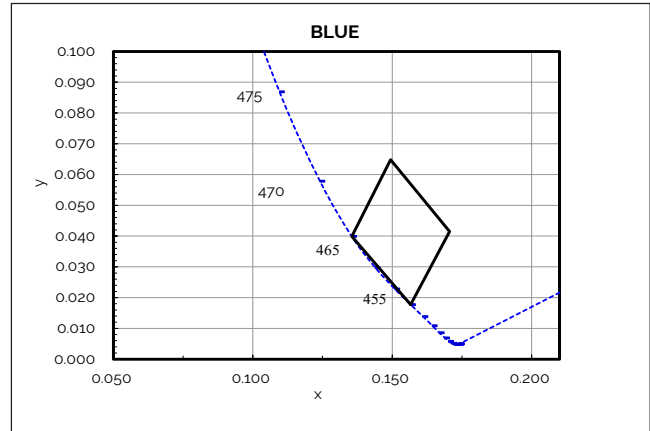
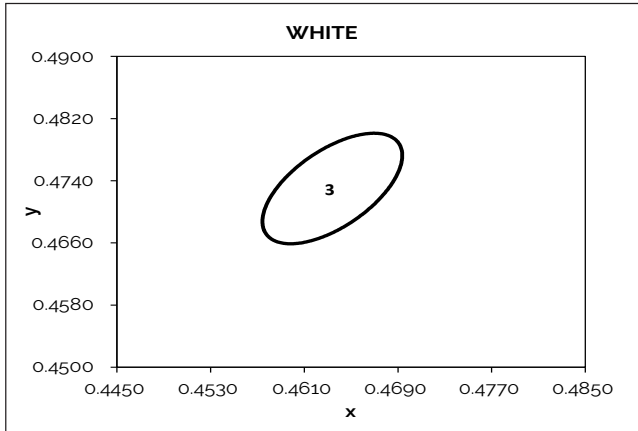

Mechanical Dimensions

Figure 17: Mechanical Drawing Specifications

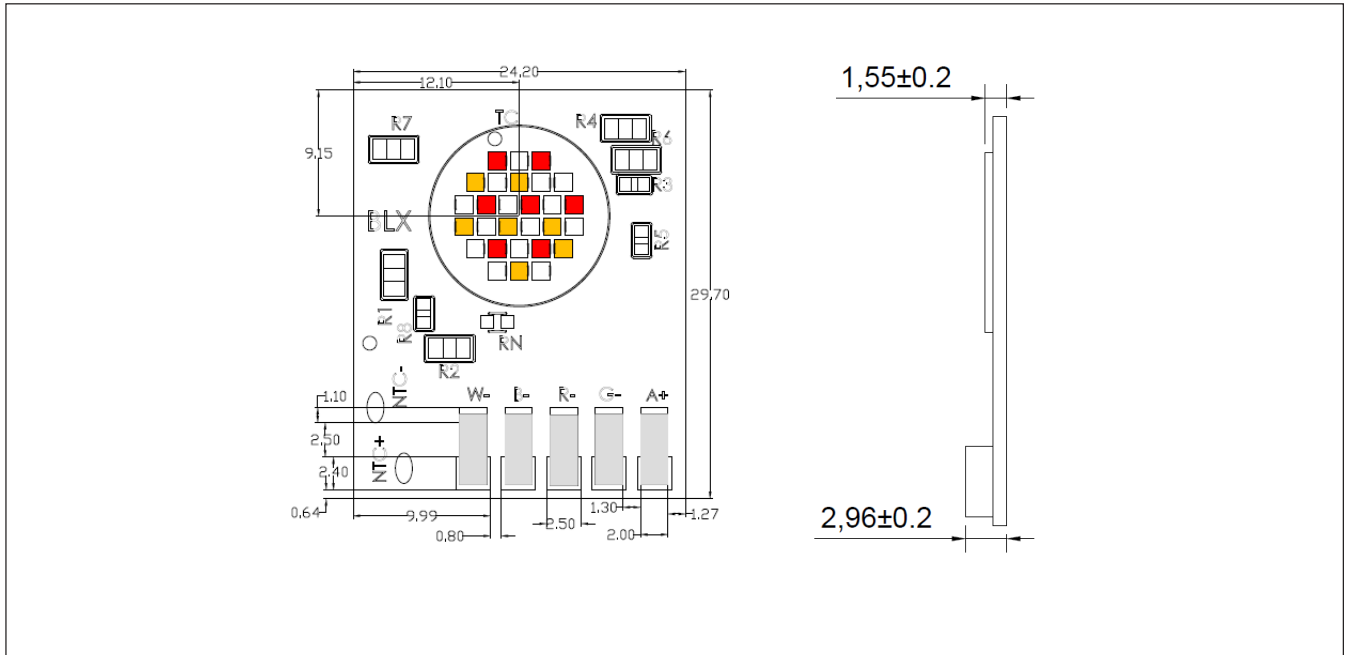

Notes for Figure 17:

1. Connectors are labeled "+" to denote positive polarity and "-" to denote negative polarity.
2. Drawings are not to scale.
3. Drawing dimensions are in millimeters.
4. Unless otherwise specified, tolerances are $\pm 0.20\text{mm}$.
5. Bridgelux maintains a flatness of 0.1 mm across the mounting surface of the array.

Connector Wiring Guideline

Figure 18: Wiring Guideline

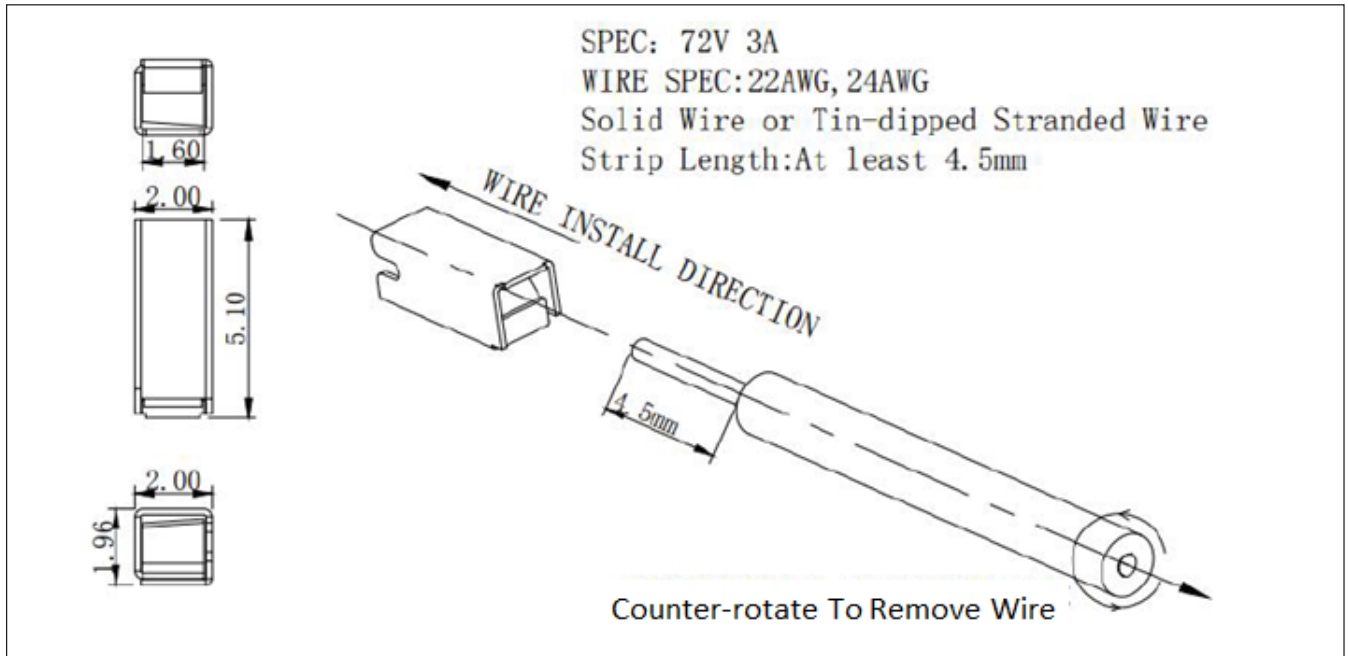

Packaging and Labeling

Figure 19: Vesta Series RGBW 10mm LES Array Packaging and Labeling



Notes for Figure 19:

1. Each tray holds 30 pcs Vesta Series RGBW 10mm arrays.
2. Four plus one trays are sealed in an anti-static bag. Up to two such bags are placed in an inner box. Up to eight inner boxes are placed in a box and shipped. Depending on quantities ordered, a bigger shipping box, containing eight boxes will be used to ship products.
3. Each bag and box is to be labeled as shown above.
4. Dimensions for each tray are 300 mm (L) x 200 mm (W) x 0.8 mm (T). Dimensions for the anti-static bag are 400 mm (W) x 300 mm (L) x 0.14 mm (T) and that of the inner box are 350 mm (L) x 245 mm (W) x 67 mm (H).

Figure 20: Product Labeling

Bridgelux arrays have laser markings on the back side of the substrate to help with product identification. In addition to the product identification markings, Bridgelux arrays also contain markings for internal Bridgelux manufacturing use only. The image below shows which markings are for customer use and which ones are for Bridgelux internal use only. The Bridgelux internal manufacturing markings are subject to change without notice, however these will not impact the form, function or performance of the array.



Design Resources

Application Notes

Vesta Series Tunable White arrays are intended for use in dry, indoor applications. Bridgelux has developed a comprehensive set of application notes and design resources to assist customers in successfully designing with the Vesta Series product family of LED array products. For a list of resources under development, visit www.bridgelux.com.

Optical Source Models

Optical source models and ray set files are available for all Bridgelux products. For a list of available formats, visit www.bridgelux.com.

3D CAD Models

Three dimensional CAD models depicting the product outline of all Bridgelux Vesta Series LED arrays are available in both IGS and STEP formats. Please contact your Bridgelux sales representative for assistance.

LM80

Please contact your Bridgelux sales representative for more information.

Precautions

CAUTION: CHEMICAL EXPOSURE HAZARD

Exposure to some chemicals commonly used in luminaire manufacturing and assembly can cause damage to the LED array. Please consult Bridgelux Application Note for additional information.

CAUTION: EYE SAFETY

Please use appropriate precautions. It is important that employees working with LEDs are trained to use them safely. Please contact your Bridgelux sales representative for more information.

CAUTION: RISK OF BURN

Do not touch the Vesta Series LED array during operation. Allow the array to cool for a sufficient period of time before handling. The Vesta Series LED array may reach elevated temperatures such that could burn skin when touched.

CAUTION

CONTACT WITH LIGHT EMITTING SURFACE (LES)

Avoid any contact with the LES. Do not touch the LES of the LED array or apply stress to the LES (yellow phosphor resin area). Contact may cause damage to the LED array.

Optics and reflectors must not be mounted in contact with the LES (yellow phosphor resin area). Optical devices may be mounted on the top surface of the Vesta Series LED array. Use the mechanical features of the LED array housing, edges and/or mounting holes to locate and secure optical devices as needed.

Disclaimers

STANDARD TEST CONDITIONS

Unless otherwise stated, array testing is performed at the nominal drive current.

MINOR PRODUCT CHANGE POLICY

The rigorous qualification testing on products offered by Bridgelux provides performance assurance. Slight cosmetic changes that do not affect form, fit, or function may occur as Bridgelux continues product optimization.

About Bridgelux: Bridging Light and Life™

At Bridgelux, we help companies, industries and people experience the power and possibility of light. Since 2002, we've designed LED solutions that are high performing, energy efficient, cost effective and easy to integrate. Our focus is on light's impact on human behavior, delivering products that create better environments, experiences and returns—both experiential and financial. And our patented technology drives new platforms for commercial and industrial luminaires.

For more information about the company, please visit

bridgelux.com

twitter.com/Bridgelux

facebook.com/Bridgelux

youtube.com/user/Bridgelux

linkedin.com/company/bridgelux

WeChat ID: BridgeluxInChina



46410 Fremont Blvd
Fremont, CA 94538 USA
Tel (925) 583-8400
www.bridgelux.com

©2025 Bridgelux, Inc. All rights reserved. Product specifications are subject to change without notice. Bridgelux, the Bridgelux stylized logo design and Vesta are registered trademarks of Bridgelux, Inc. Bridging Light and Life is a trademark of Bridgelux, Inc. All other trademarks are the property of their respective owners.

DS591 Bridgelux Vesta Series RGBW Gen2 10mm Array With CSP Data Sheet Rev. A (06/2025)