



Bridgelux® SMD 5050 2W 6V

Product Data Sheet DS2501

Introduction

SMD 5050

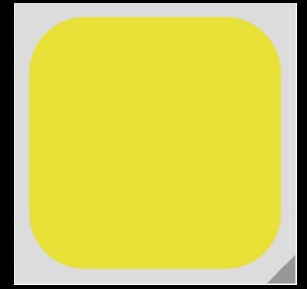

Bridgelux flip chip SMD 5050 is hot-color targeted, which ensures that the LEDs fall within their specified color bin at the typical application conditions of 85°C. Flip chip solution delivers high efficacy and high reliability performance, plus with its broad lumen coverage and wide range of CCT and CRI options, the SMD 5050 provides unparalleled design-in flexibility for indoor and outdoor lighting applications. The SMD 5050 is ideal as a drop-in replacement for emitters with an industry standard 5.0mm x 5.0mm footprint.

Features

- Industry-standard 5050 footprint with 6 V configuration
- Hot-color targeting ensures that color is within the bin at the typical application condition of 85°C
- 3- and 5-step MacAdam ellipse options
- RoHS compliant and lead free
- Multiple CCT and CRI configurations for a wide range of lighting applications

Benefits

- Lower operating and manufacturing cost
- Ease of design and rapid go-to-market
- Uniform consistent white light
- Compliant with environmental standards
- Design flexibility

Contents

Product Feature Map	2
Product Nomenclature	2
Product Selection Guide	3
Electrical Characteristics	5
Product Performance at Commonly Used Drive Currents	6
Absolute Maximum Ratings	9
Product Bin Definitions	10
Performance Curves	12
Typical Radiation Pattern	16
Typical Color Spectrum	17
Mechanical Dimensions	18
Reliability	19
Reflow Characteristics	20
Packaging	21
Design Resources	23
Precautions	23
Disclaimers	23
About Bridgelux	24

Product Feature Map

Bridgelux SMD LED products come in industry standard package sizes and follow ANSI binning standards. These LEDs are optimized for cost and performance, helping to ensure highly competitive system lumen per dollar performance while addressing the stringent efficacy and reliability standards required for modern lighting applications.

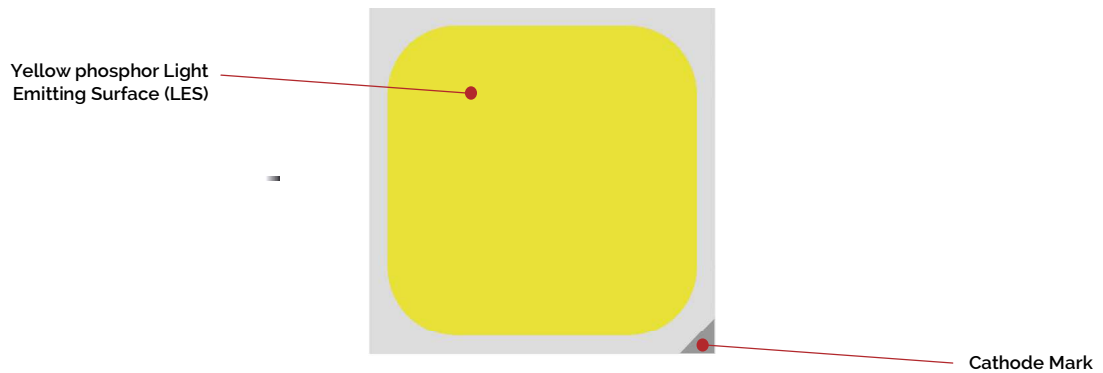

Product Nomenclature

The part number designation for Bridgelux SMD 5050 is explained as follows:

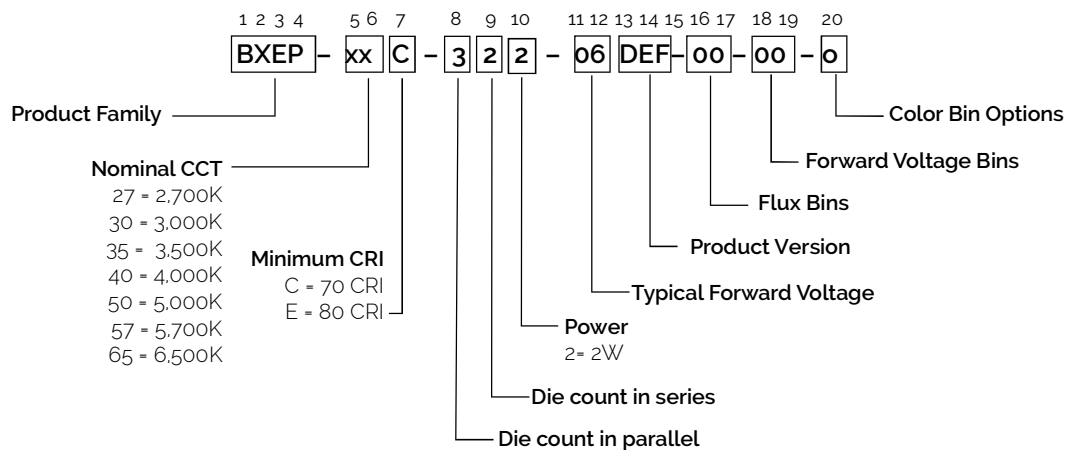

Product Selection Guide

The following product configurations are available:

Table 1: Selection Guide, Pulsed Measurement Data at 350mA ($T_j = T_{sp} = 25^\circ\text{C}$)

Part Number ^{1,6}	Nominal CCT ² (K)	CRI ^{3,5}	Nominal Drive Current (mA)	Forward Voltage ^{4,5} (V)			Typical Pulsed Flux (lm) ^{4,5}	Typical Power (W)	Typical Efficacy (lm/W)
				Min	Typical	Max			
BXEP-22C-322-06DEF-00-00-0	2200	70	350	5.20	5.50	5.80	374	1.9	194
BXEP-27C-322-06DEF-00-00-0	2700	70	350	5.20	5.50	5.80	397	1.9	206
BXEP-30C-322-06DEF-00-00-0	3000	70	350	5.20	5.50	5.80	411	1.9	213
BXEP-35C-322-06DEF-00-00-0	3500	70	350	5.20	5.50	5.80	426	1.9	222
BXEP-40C-322-06DEF-00-00-0	4000	70	350	5.20	5.50	5.80	442	1.9	230
BXEP-50C-322-06DEF-00-00-0	5000	70	350	5.20	5.50	5.80	442	1.9	230
BXEP-57C-322-06DEF-00-00-0	5700	70	350	5.20	5.50	5.80	442	1.9	230
BXEP-65C-322-06DEF-00-00-0	6500	70	350	5.20	5.50	5.80	432	1.9	224
BXEP-22E-322-06DEF-00-00-0	2200	80	350	5.20	5.50	5.80	347	1.9	180
BXEP-27E-322-06DEF-00-00-0	2700	80	350	5.20	5.50	5.80	369	1.9	192
BXEP-30E-322-06DEF-00-00-0	3000	80	350	5.20	5.50	5.80	381	1.9	198
BXEP-35E-322-06DEF-00-00-0	3500	80	350	5.20	5.50	5.80	395	1.9	205
BXEP-40E-322-06DEF-00-00-0	4000	80	350	5.20	5.50	5.80	410	1.9	213
BXEP-50E-322-06DEF-00-00-0	5000	80	350	5.20	5.50	5.80	410	1.9	213
BXEP-57E-322-06DEF-00-00-0	5700	80	350	5.20	5.50	5.80	410	1.9	213
BXEP-65E-322-06DEF-00-00-0	6500	80	350	5.20	5.50	5.80	400	1.9	208

Notes for Table 1 :

1. The last 7 characters (including hyphens '-') refer to flux bins, forward voltage bins, and color bin options, respectively. "00-00-0" denotes the full distribution of flux, forward voltage, and 5 SDCM color.

Example: BXEP-40C-322-06DEF-00-00-0 refers to the full distribution of flux, forward voltage, and color within a 4000K 5-step ANSI standard chromaticity region with a minimum of 70CRI, 3x2 die configuration, 2 W power, 5.5 V typical forward voltage.

2. Product CCT is hot targeted at $T_{sp} = 85^\circ\text{C}$. Nominal CCT as defined by ANSI C78.377-2011.

3. Listed CRIs are minimum values and include test tolerance.

4. Products tested under pulsed condition (10ms pulse width) at nominal drive current where $T_j = T_{sp} = 25^\circ\text{C}$.

5. Bridgelux maintains a $\pm 7.5\%$ tolerance on luminous flux measurements, $\pm 0.1\text{V}$ tolerance on forward voltage measurements, and ± 2 tolerance on CRI measurements for the SMD 5050.

6. Refer to Table 6 and Table 7 for Bridgelux SMD 5050 Luminous Flux Binning and Forward Voltage Binning information.

Product Selection Guide

The following product configurations are available:

Table 2: Selection Guide, Pulsed Measurement Data at 350mA ($T_j = T_{sp} = 85^\circ\text{C}$)

Part Number ^{1,6}	Nominal CCT ² (K)	CRI ^{3,5}	Nominal Drive Current (mA)	Forward Voltage ^{4,5} (V)			Typical Pulsed Flux (lm) ^{4,5}	Typical Power (W)	Typical Efficacy (lm/W)
				Min	Typical	Max			
BXEP-22C-322-06DEF-00-00-0	2200	70	350	5.00	5.31	5.60	348	1.9	187
BXEP-27C-322-06DEF-00-00-0	2700	70	350	5.00	5.31	5.60	369	1.9	199
BXEP-30C-322-06DEF-00-00-0	3000	70	350	5.00	5.31	5.60	382	1.9	206
BXEP-35C-322-06DEF-00-00-0	3500	70	350	5.00	5.31	5.60	397	1.9	213
BXEP-40C-322-06DEF-00-00-0	4000	70	350	5.00	5.31	5.60	411	1.9	221
BXEP-50C-322-06DEF-00-00-0	5000	70	350	5.00	5.31	5.60	411	1.9	221
BXEP-57C-322-06DEF-00-00-0	5700	70	350	5.00	5.31	5.60	411	1.9	221
BXEP-65C-322-06DEF-00-00-0	6500	70	350	5.00	5.31	5.60	401	1.9	216
BXEP-22E-322-06DEF-00-00-0	2200	80	350	5.00	5.31	5.60	319	1.9	172
BXEP-27E-322-06DEF-00-00-0	2700	80	350	5.00	5.31	5.60	339	1.9	183
BXEP-30E-322-06DEF-00-00-0	3000	80	350	5.00	5.31	5.60	351	1.9	189
BXEP-35E-322-06DEF-00-00-0	3500	80	350	5.00	5.31	5.60	363	1.9	196
BXEP-40E-322-06DEF-00-00-0	4000	80	350	5.00	5.31	5.60	377	1.9	203
BXEP-50E-322-06DEF-00-00-0	5000	80	350	5.00	5.31	5.60	377	1.9	203
BXEP-57E-322-06DEF-00-00-0	5700	80	350	5.00	5.31	5.60	377	1.9	203
BXEP-65E-322-06DEF-00-00-0	6500	80	350	5.00	5.31	5.60	368	1.9	198

Notes for Table 2 :

- The last 7 characters (including hyphens '-') refer to flux bins, forward voltage bins, and color bin options, respectively. "00-00-0" denotes the full distribution of flux, forward voltage, and 5 SDCM color.
Example: BXEP-40C-322-06DEF-00-00-0 refers to the full distribution of flux, forward voltage, and color within a 4000K 5-step ANSI standard chromaticity region with a minimum of 70CRI, 3x2 die configuration, 2 W power, 5.31 V typical forward voltage.
- Product CCT is hot targeted at $T_{sp} = 85^\circ\text{C}$. Nominal CCT as defined by ANSI C78.377-2011.
- Listed CRIs are minimum values and include test tolerance.
- Products tested under pulsed condition (10ms pulse width) at nominal drive current where $T_j = T_{sp} = 85^\circ\text{C}$.
- Bridgelux maintains a $\pm 7.5\%$ tolerance on luminous flux measurements, $\pm 0.1\text{V}$ tolerance on forward voltage measurements, and ± 2 tolerance on CRI measurements for the SMD 5050.
- Refer to Table 6 and Table 7 for Bridgelux SMD 5050 Luminous Flux Binning and Forward Voltage Binning information.

Electrical Characteristics

Table 3: Electrical Characteristics

Part Number ¹	Drive Current (mA)	Forward Voltage (V) ^{2,3}			Typical Temperature Coefficient of Forward Voltage $\Delta V_f / \Delta T$ (mV/°C)	Typical Thermal Resistance Junction to Solder Point ^{4, 5} R_{j-sp} (°C/W)
		Minimum	Typical	Maximum		
BXEP-xxC-322-06DEF-00-00-0	350	5.20	5.50	5.80	-2.7	2

Notes for Table 3:

- The last 7 characters (including hyphens '-') refer to flux bins, forward voltage bins, and color bin options, respectively. "00-00-0" denotes the full distribution of flux, forward voltage, and 5 SDCM color.
Example: BXEP-40C-322-06DEF-00-00-0 refers to the full distribution of flux, forward voltage, and color within a 4000K 5-step ANSI standard chromaticity.
- Bridgelux maintains a tolerance of $\pm 0.1V$ on forward voltage measurements. Voltage minimum and maximum values at the nominal drive current are guaranteed by 100% test.
- Products tested under pulsed condition (10ms pulse width) at nominal drive current where $T_{sp} = 25^\circ C$.
- Thermal Resistance values based on 4000K 70CRI product.
- Thermal resistance value was calculated using total electrical input power; optical power was not subtracted from input power.

Performance at Commonly Used Drive Currents

SMD 5050 LEDs are tested to the specifications shown using the nominal drive currents in Table 1. SMD 5050 may also be driven at other drive currents dependent on specific application design requirements. The performance at any drive current can be derived from the current vs. voltage characteristics shown in Figure 2 and the relative luminous flux vs. current characteristics shown in Figure 3. The performance at commonly used drive currents is summarized in Table 3

Table 4: Product Performance at Commonly Used Drive Currents

Part Number	CRI	Drive Current ¹ (mA)	Typical V _f T _j = 25°C (V)	Typical Power T _j = 25°C (W)	Typical Flux ² T _j = 25°C (lm)	Typical Pulsed Flux ³ T _j = 85°C (lm)	Typical Efficacy T _j = 25°C (lm/W)
BXEP-22C-322-06DEF-00-00-0	70	100	5.3	0.5	110	102	209
		180	5.4	1.0	197	184	204
		350	5.5	1.9	374	348	194
		500	5.6	2.8	525	488	186
		650	5.8	3.7	669	622	179
		750	5.8	4.4	765	711	175
		900	5.9	5.3	904	841	170
		1050	6.0	6.3	1062	988	168
BXEP-27C-322-06DEF-00-00-0	70	100	5.3	0.5	117	109	222
		180	5.4	1.0	209	195	217
		350	5.5	1.9	397	369	206
		500	5.6	2.8	557	518	198
		650	5.8	3.7	710	660	190
		750	5.8	4.4	811	755	185
		900	5.9	5.3	959	892	179
		1050	6.0	6.3	1127	1048	178
BXEP-30C-322-06DEF-00-00-0	70	100	5.3	0.5	121	112	229
		180	5.4	1.0	217	201	224
		350	5.5	1.9	411	382	213
		500	5.6	2.8	576	536	204
		650	5.8	3.7	734	683	196
		750	5.8	4.4	839	780	192
		900	5.9	5.3	992	922	186
		1050	6.0	6.3	1166	1084	184
BXEP-35C-322-06DEF-00-00-0	70	100	5.3	0.5	125	117	238
		180	5.4	1.0	225	209	233
		350	5.5	1.9	426	397	221
		500	5.6	2.8	598	556	212
		650	5.8	3.7	762	709	204
		750	5.8	4.4	871	810	199
		900	5.9	5.3	1030	958	193
		1050	6.0	6.3	1210	1125	191
BXEP-40C-322-06DEF-00-00-0	70	100	5.3	0.5	130	121	247
		180	5.4	1.0	233	217	241
		350	5.5	1.9	442	411	229
		500	5.6	2.8	620	577	220
		650	5.8	3.7	790	735	211
		750	5.8	4.4	903	840	206
		900	5.9	5.3	1067	993	200
		1050	6.0	6.3	1254	1166	198

Notes for Table 4:

1. Alternate drive currents in Table 4 are provided for reference only and are not a guarantee of performance.
2. Bridgelux maintains a ± 7% tolerance on flux measurements.
3. Typical Pulsed performance values are provided as reference only and are not a guarantee of performance.

Performance at Commonly Used Drive Currents

Table 4: Product Performance at Commonly Used Drive Currents

Part Number	CRI	Drive Current ¹ (mA)	Typical V _f T _j = 25°C (V)	Typical Power T _j = 25°C (W)	Typical Flux ² T _j = 25°C (lm)	Typical Pulsed Flux ³ T _j = 85°C (lm)	Typical Efficacy T _j = 25°C (lm/W)
BXEP-50C-322-06DEF-00-00-0	70	100	5.3	0.5	130	121	247
		180	5.4	1.0	233	217	241
		350	5.5	1.9	442	411	229
		500	5.6	2.8	620	577	220
		650	5.8	3.7	790	735	211
		750	5.8	4.4	903	840	206
		900	5.9	5.3	1067	993	200
		1050	6.0	6.3	1254	1166	198
BXEP-57C-322-06DEF-00-00-0	70	100	5.3	0.5	130	121	247
		180	5.4	1.0	233	217	241
		350	5.5	1.9	442	411	229
		500	5.6	2.8	620	577	220
		650	5.8	3.7	790	735	211
		750	5.8	4.4	903	840	206
		900	5.9	5.3	1067	993	200
		1050	6.0	6.3	1254	1166	198
BXEP-65C-322-06DEF-00-00-0	70	100	5.3	0.5	127	118	241
		180	5.4	1.0	227	212	236
		350	5.5	1.9	432	401	224
		500	5.6	2.8	606	563	215
		650	5.8	3.7	771	717	206
		750	5.8	4.4	882	820	201
		900	5.9	5.3	1042	969	195
		1050	6.0	6.3	1225	1139	193
BXEP-22E-322-06DEF-00-00-0	80	100	5.3	0.5	102	94	194
		180	5.4	1.0	183	168	190
		350	5.5	1.9	347	319	180
		500	5.6	2.8	487	448	173
		650	5.8	3.7	620	571	166
		750	5.8	4.4	709	652	162
		900	5.9	5.3	838	771	157
		1050	6.0	6.3	985	906	155
BXEP-27E-322-06DEF-00-00-0	80	100	5.3	0.5	109	100	206
		180	5.4	1.0	194	179	202
		350	5.5	1.9	369	339	191
		500	5.6	2.8	518	476	184
		650	5.8	3.7	660	607	176
		750	5.8	4.4	754	693	172
		900	5.9	5.3	891	820	167
		1050	6.0	6.3	1047	963	165
BXEP-30E-322-06DEF-00-00-0	80	100	5.3	0.5	112	103	213
		180	5.4	1.0	201	185	208
		350	5.5	1.9	381	351	197
		500	5.6	2.8	535	492	190
		650	5.8	3.7	681	627	182
		750	5.8	4.4	778	716	178
		900	5.9	5.3	920	846	172
		1050	6.0	6.3	1081	995	171

Notes for Table 4:

1. Alternate drive currents in Table 4 are provided for reference only and are not a guarantee of performance.
2. Bridgelux maintains a ± 7% tolerance on flux measurements.
3. Typical Pulsed performance values are provided as reference only and are not a guarantee of performance.

Performance at Commonly Used Drive Currents

Table 4: Product Performance at Commonly Used Drive Currents

Part Number	CRI	Drive Current ¹ (mA)	Typical V _f T _j = 25°C (V)	Typical Power T _j = 25°C (W)	Typical Flux ² T _j = 25°C (lm)	Typical Pulsed Flux ³ T _j = 85°C (lm)	Typical Efficacy T _j = 25°C (lm/W)
BXEP-35E-322-06DEF-00-00-0	80	100	5.3	0.5	116	107	221
		180	5.4	1.0	208	192	216
		350	5.5	1.9	395	363	205
		500	5.6	2.8	554	510	197
		650	5.8	3.7	706	650	189
		750	5.8	4.4	807	742	184
		900	5.9	5.3	954	877	178
		1050	6.0	6.3	1121	1031	177
BXEP-40E-322-06DEF-00-00-0	80	100	5.3	0.5	121	111	229
		180	5.4	1.0	216	199	224
		350	5.5	1.9	410	377	212
		500	5.6	2.8	575	529	204
		650	5.8	3.7	733	674	196
		750	5.8	4.4	837	770	191
		900	5.9	5.3	990	911	185
		1050	6.0	6.3	1163	1070	184
BXEP-50E-322-06DEF-00-00-0	80	100	5.3	0.5	121	111	229
		180	5.4	1.0	216	199	224
		350	5.5	1.9	410	377	212
		500	5.6	2.8	575	529	204
		650	5.8	3.7	733	674	196
		750	5.8	4.4	837	770	191
		900	5.9	5.3	990	911	185
		1050	6.0	6.3	1163	1070	184
BXEP-57E-322-06DEF-00-00-0	80	100	5.3	0.5	121	111	229
		180	5.4	1.0	216	199	224
		350	5.5	1.9	410	377	212
		500	5.6	2.8	575	529	204
		650	5.8	3.7	733	674	196
		750	5.8	4.4	837	770	191
		900	5.9	5.3	990	911	185
		1050	6.0	6.3	1163	1070	184
BXEP-65E-322-06DEF-00-00-0	80	100	5.3	0.5	118	108	223
		180	5.4	1.0	211	194	218
		350	5.5	1.9	400	368	207
		500	5.6	2.8	561	516	199
		650	5.8	3.7	715	658	191
		750	5.8	4.4	817	752	187
		900	5.9	5.3	966	889	181
		1050	6.0	6.3	1135	1044	179

Notes for Table 4:

1. Alternate drive currents in Table 4 are provided for reference only and are not a guarantee of performance.
2. Bridgelux maintains a ± 7% tolerance on flux measurements.
3. Typical Pulsed performance values are provided as reference only and are not a guarantee of performance.

Absolute Maximum Ratings

Table 5: Maximum Ratings

Parameter	Maximum Rating
LED Junction Temperature (T_j)	135°C
Storage Temperature	-40°C to +105°C
Operating Solder Point Temperature (T_{sp})	-40°C to +105°C
Soldering Temperature	260°C or lower for a maximum of 3 seconds
Maximum Drive Current ¹	1050 mA
Maximum Peak Pulsed Forward Current ²	1300 mA
Maximum Reverse Voltage ³	-10
Moisture Sensitivity Rating	MSL 3
Electrostatic Discharge	2KV HBM. JEDEC-JS-001-HBM and JEDEC-JS-001-2012

Notes for Table 5:

1. Maximum drive current may be limited by the solder point temperature. Please see Figure 7 for further details.
2. Bridgelux recommends a maximum duty cycle of 10% and pulse width of 10 ms when operating LED SMD at maximum peak pulsed current specified. Maximum peak pulsed current indicate values where LED SMD can be driven without catastrophic failures.
3. Light emitting diodes are not designed to be driven in reverse voltage and will not produce light under this condition. Maximum rating provided for reference only.

Product Bin Definitions

Table 6 lists the standard photometric luminous flux bins for Bridgelux SMD 5050 LEDs. Although several bins are listed, product availability in a particular bin varies by production run and by product performance. Not all bins are available in all CCTs.

Table 6: Luminous Flux Bin Definitions at 350mA, $T_{sp}=25^{\circ}\text{C}$

Bin Code	Minimum	Maximum	Unit	Condition
D9	310	330	lm	$I_F=350\text{mA}$
E6	330	350		
E7	350	370		
E8	370	390		
E9	390	410		
F6	410	430		
F7	430	450		
F8	450	470		

Note for Table 6:

1. Bridgelux maintains a tolerance of $\pm 7.5\%$ on luminous flux measurements.

Table 7: Forward Voltage Bin Definition at 350mA, $T_{sp}=25^{\circ}\text{C}$

Bin Code	Minimum	Maximum	Unit	Condition
BL	5.2	5.4	V	$I_F=350\text{mA}$
BM	5.4	5.6		
BN	5.6	5.8		

Note for Table 7:

1. Bridgelux maintains a tolerance of $\pm 0.1\text{V}$ on forward voltage measurements.

Product Bin Definitions

Table 8: 3- and 5-step MacAdam Ellipse Color Bin Definitions, $T_{sp}=85^{\circ}\text{C}$

CCT	Color Space	Center Point		Major Axis	Minor Axis	Ellipse Rotation Angle	Color Bin
		X	Y				
2200K	3	0.5056	0.4152	0.00863	0.00398	49.270	3
	5	0.5056	0.4152	0.01438	0.00663	49.270	5
2700K	3	0.4578	0.4101	0.00810	0.00420	53.700	3
	5	0.4578	0.4101	0.01350	0.00700	53.700	5
3000K	3	0.4338	0.4030	0.00834	0.00408	53.220	3
	5	0.4338	0.4030	0.01390	0.00680	53.220	5
3500K	3	0.4073	0.3917	0.00927	0.00414	54.000	3
	5	0.4073	0.3917	0.01545	0.00690	54.000	5
4000K	3	0.3818	0.3797	0.00939	0.00402	53.720	3
	5	0.3818	0.3797	0.01565	0.00670	53.720	5
5000K	3	0.3447	0.3553	0.00822	0.00354	59.620	3
	5	0.3447	0.3553	0.01370	0.00590	59.620	5
5700K	3	0.3287	0.3417	0.00746	0.00320	59.090	3
	5	0.3287	0.3417	0.01243	0.00533	59.090	5
6500K	3	0.3123	0.3282	0.00669	0.00285	58.570	3
	5	0.3123	0.3282	0.01115	0.00475	58.570	5

Notes for Table 8:

1. Color binning at $T_{sp}=85^{\circ}\text{C}$
2. Bridgelux maintains a tolerance of ± 0.007 on x and y color coordinates in the CIE 1931 color space.

Performance Curves

Figure 1: C.I.E. 1931 Chromaticity Diagram (2 Color Bin Structure, Hot-color Targeted at $T_{sp} = 85^{\circ}\text{C}$)

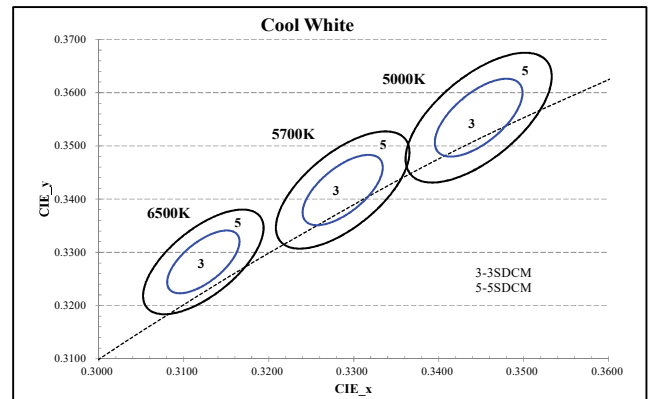
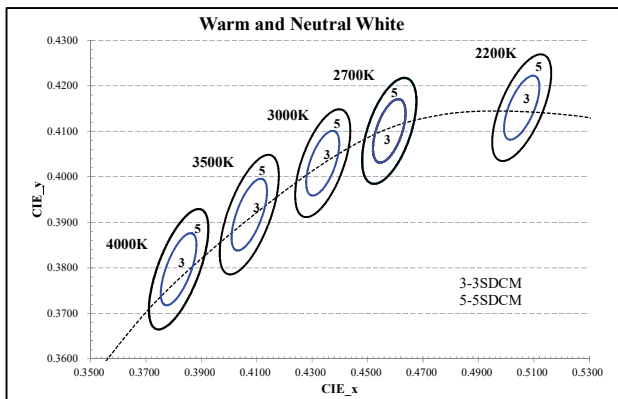

Performance Curves

Figure 2: Drive Current vs. Voltage ($T_{sp}=25^{\circ}\text{C}$)

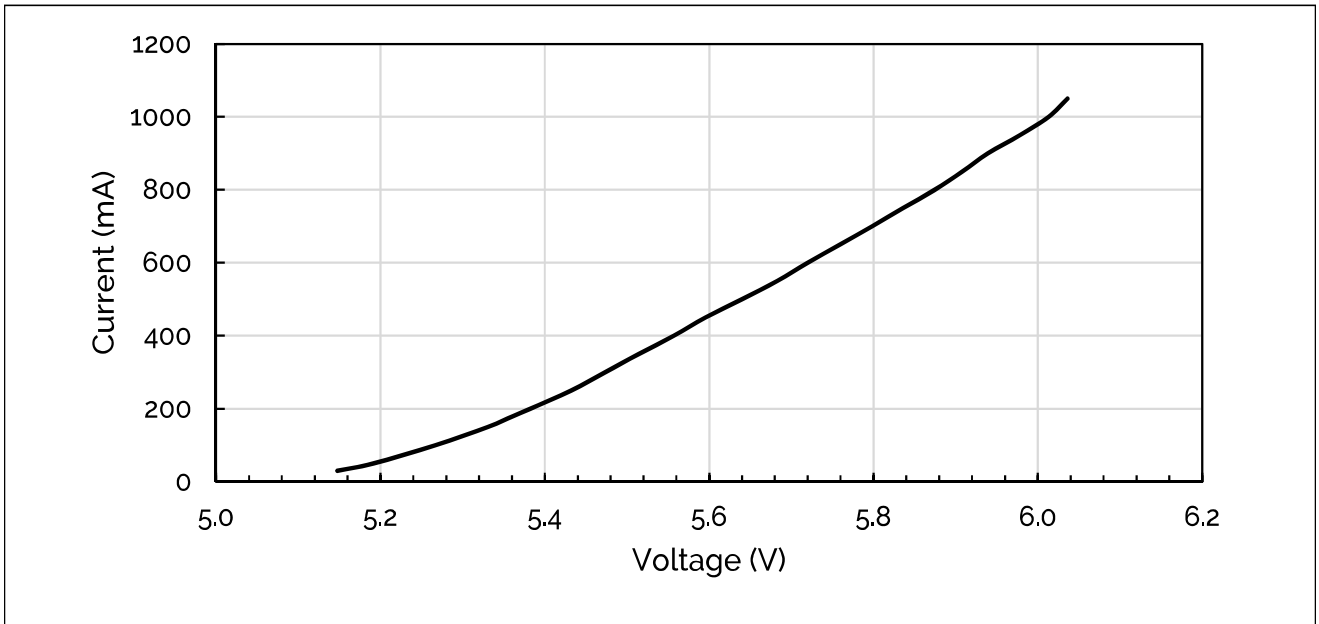
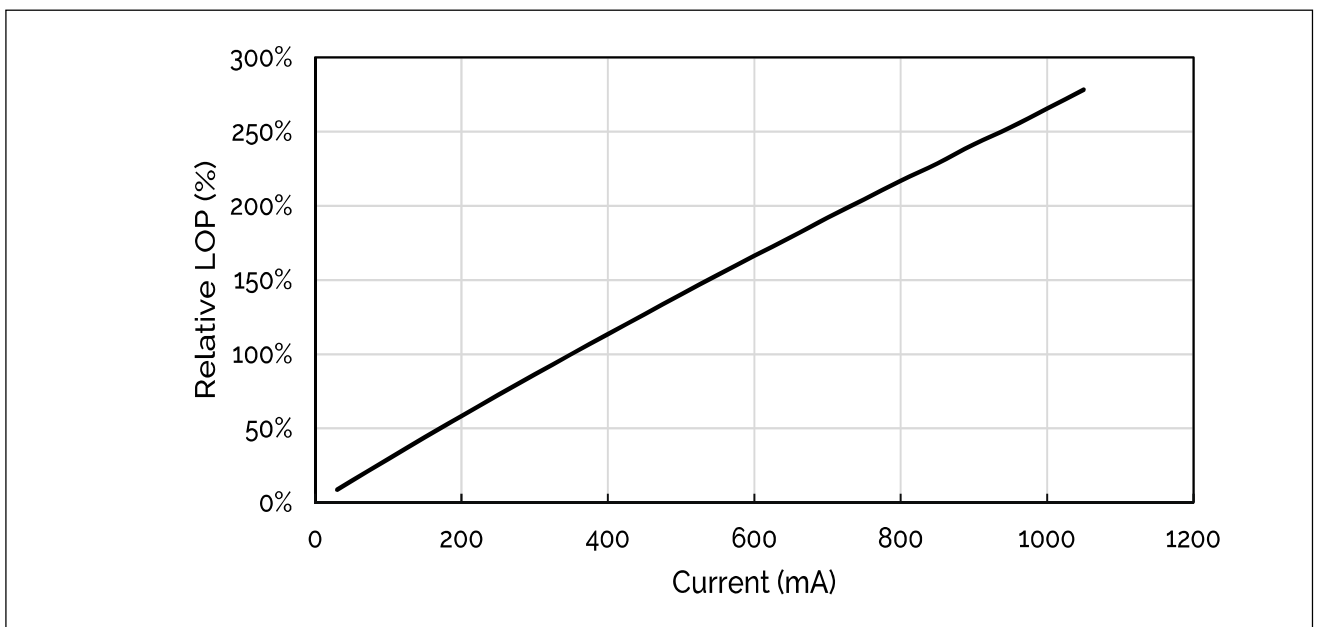

Figure 3: Relative Luminous Flux vs. Drive Current ($T_{sp}=25^{\circ}\text{C}$)



Note for Figure 3:

1. Pulse width modulation (PWM) is recommended for dimming effects.

Performance Curves

Figure 4: Relative DC Flux vs. Solder Point Temperature

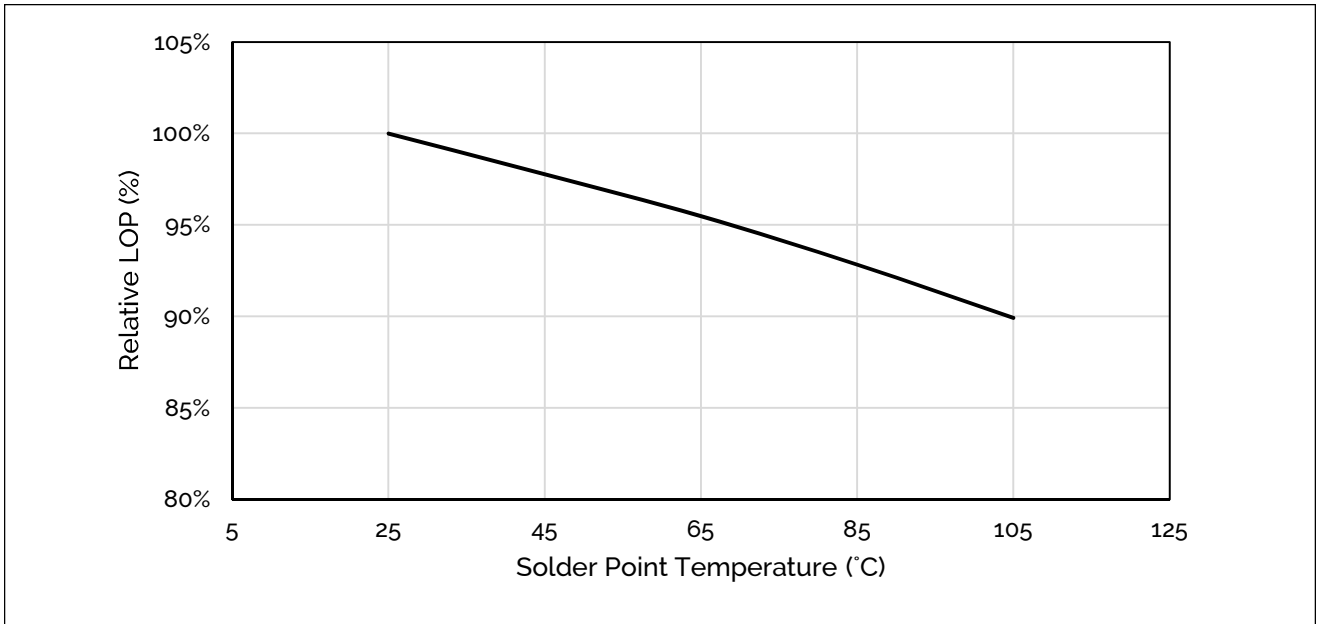
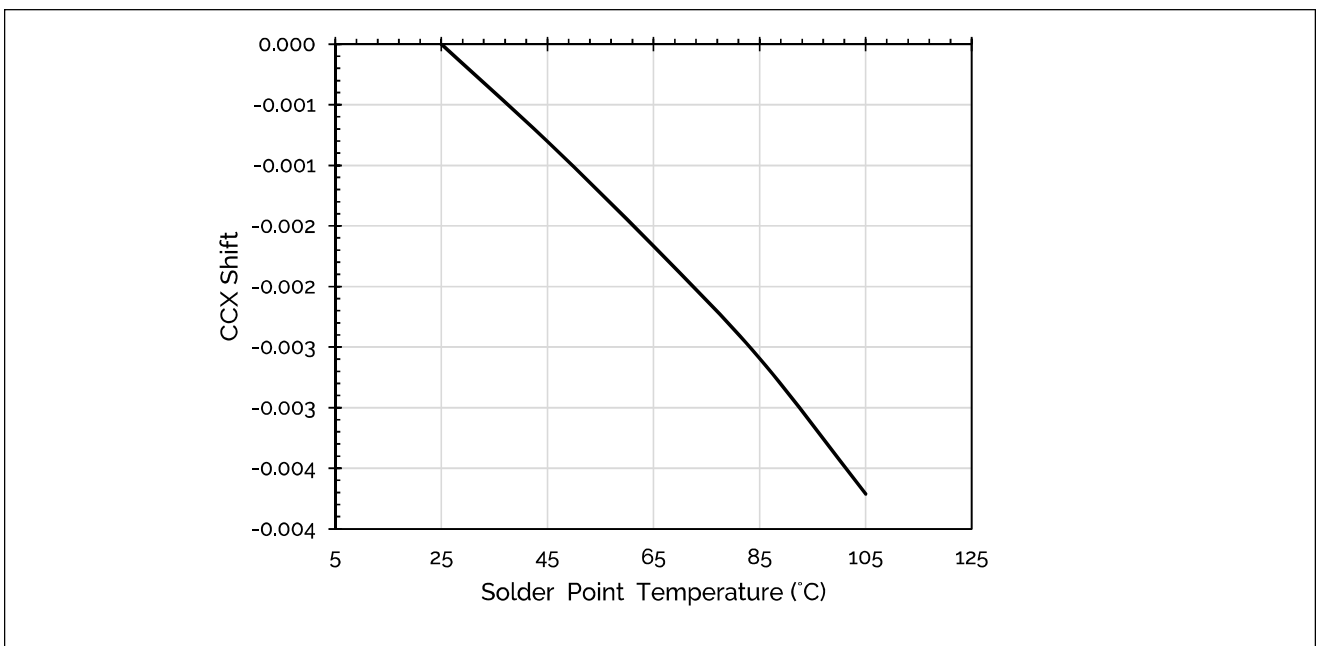

Figure 5: Typical DC ccx Shift vs. Solder Point Temperature



Notes for Figures 4 & 5:

1. Characteristics shown for 4000K and 70 CRI.
2. For other color SKUs, the shift in color will vary. Please contact your Bridgelux Sales Representative for more information.

Performance Curves

Figure 6: Typical DC ccy Shift vs. Solder Point Temperature

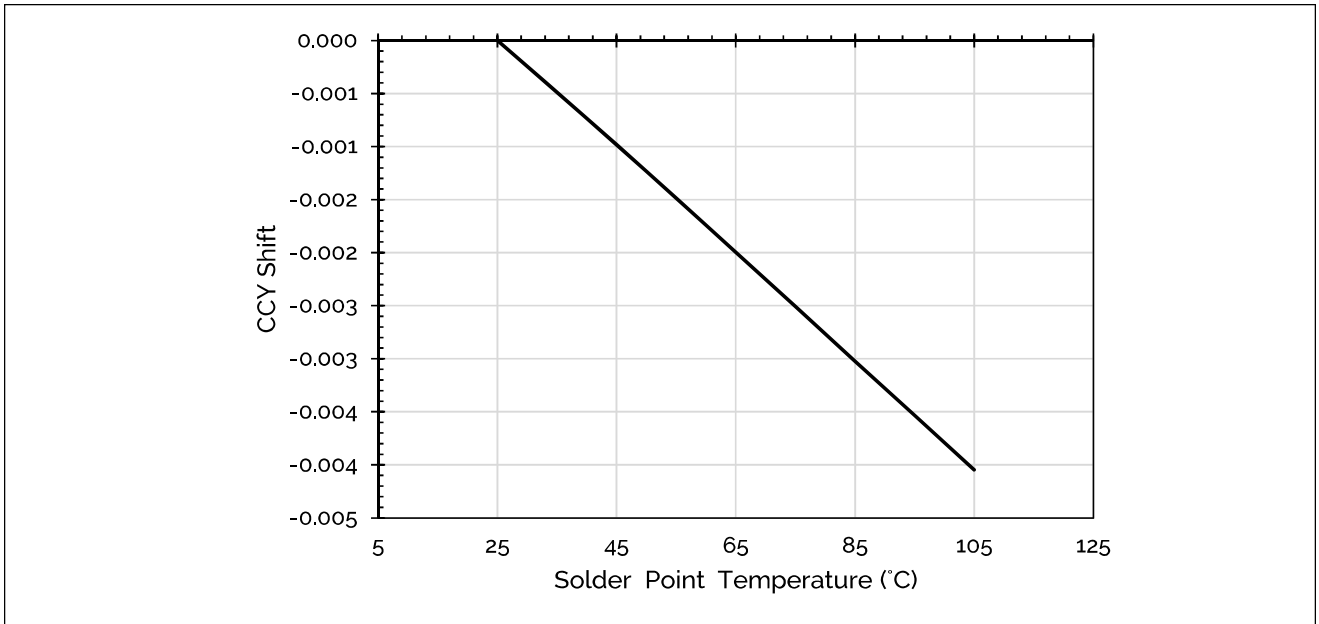

Notes for Figure 6:

1. Characteristics shown for 4000K and 70 CRI.
2. For other color SKUs, the shift in color will vary. Please contact your Bridgelux Sales Representative for more information.

Figure 7: Drive Current Derating Curve

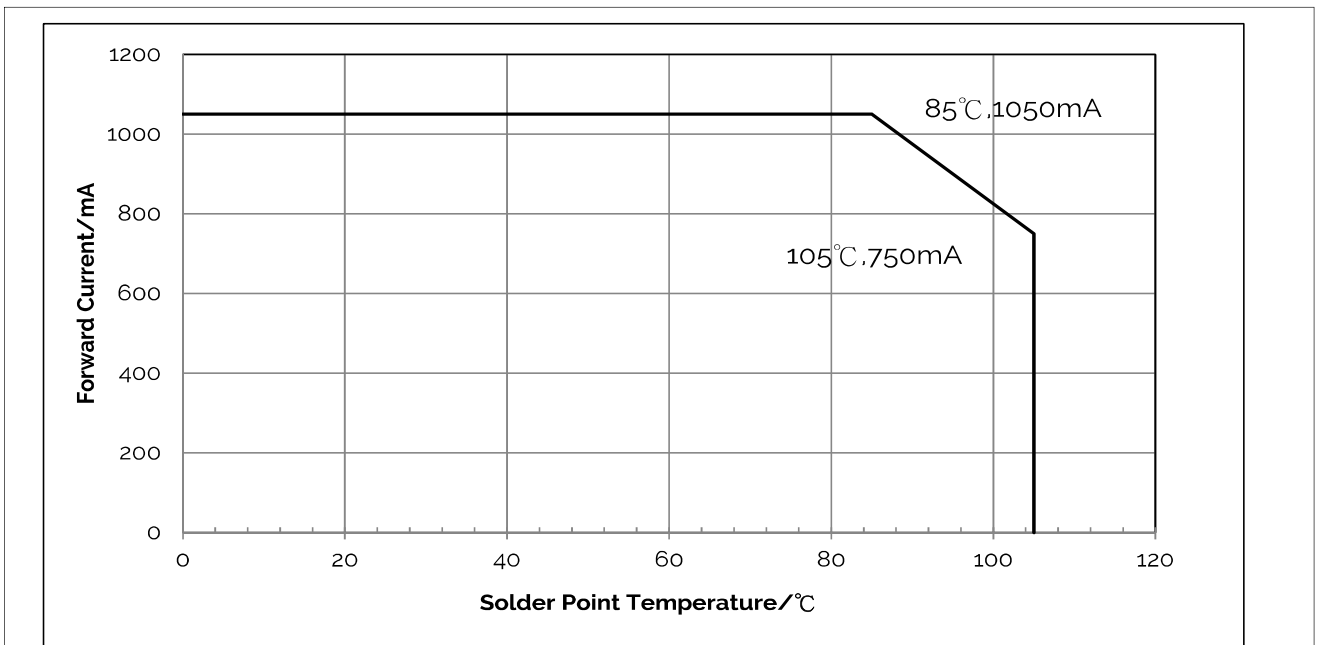

Typical Radiation Pattern

Figure 8: Typical Spatial Radiation Pattern at 350mA, $T_{sp} = 25^{\circ}\text{C}$

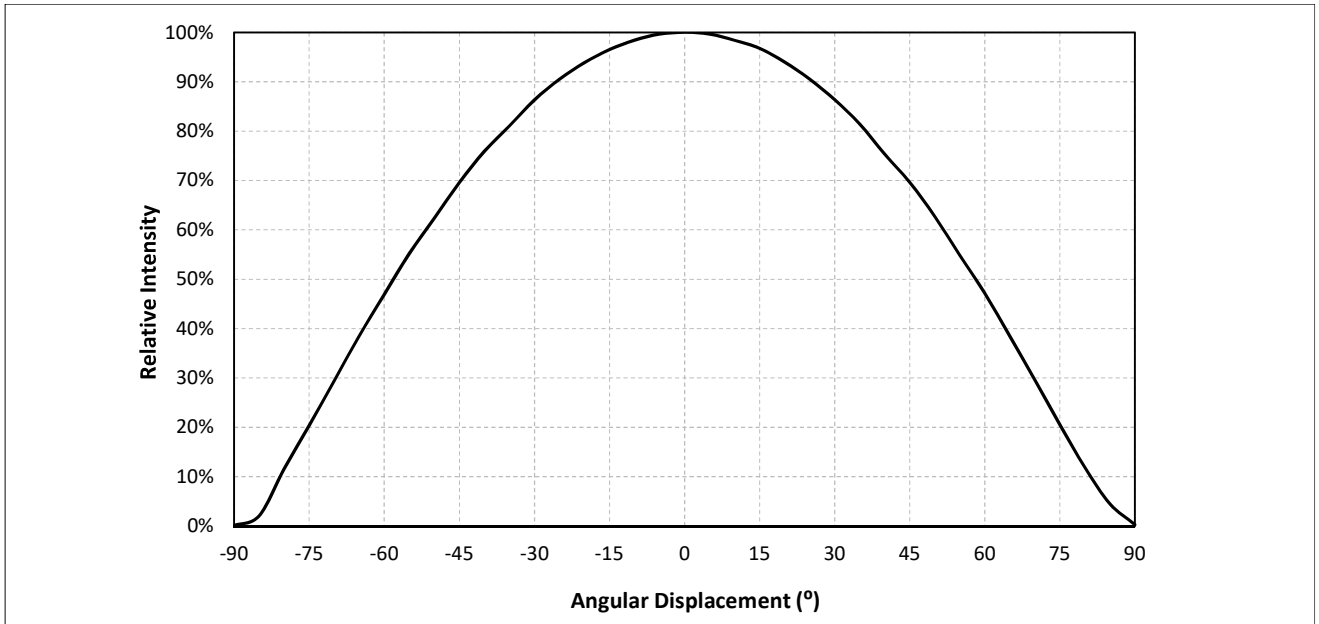

Notes for Figure 8:

1. Typical viewing angle is 116° .
2. The viewing angle is defined as the off axis angle from the centerline where luminous intensity (Iv) is $\frac{1}{2}$ of the peak value.

Figure 9: Typical Polar Radiation Pattern at 350mA, $T_{sp} = 25^{\circ}\text{C}$

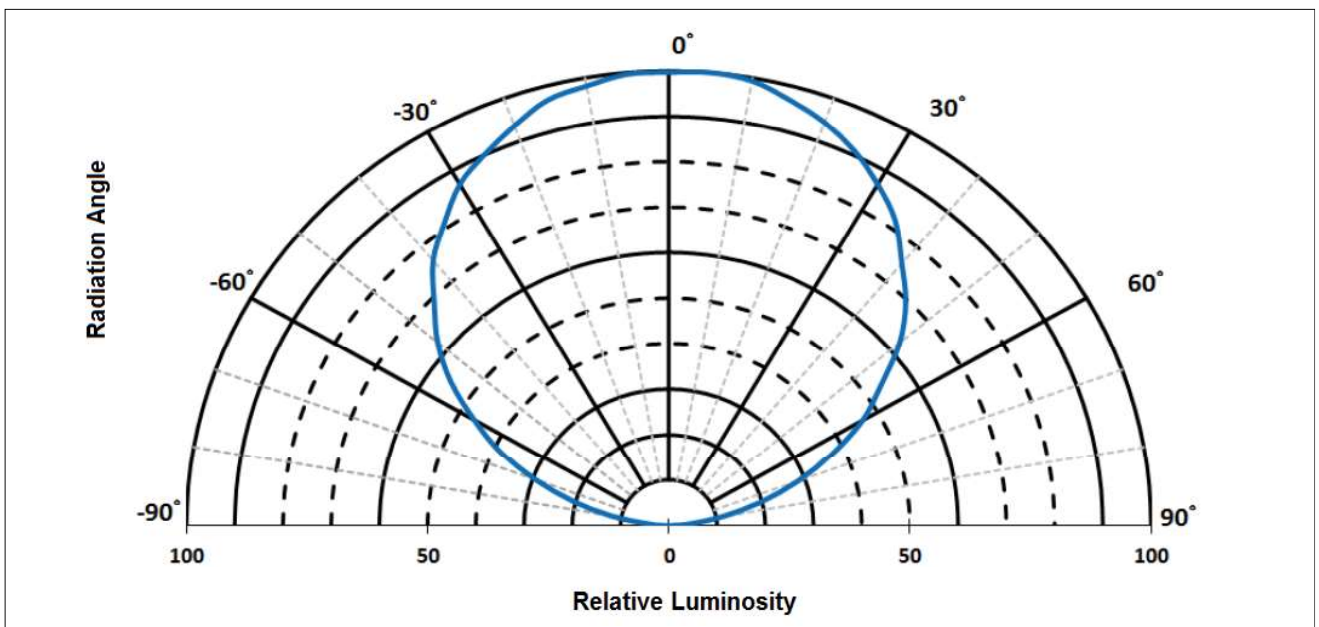

Typical Color Spectrum

Figure 10: Typical Color Spectrum

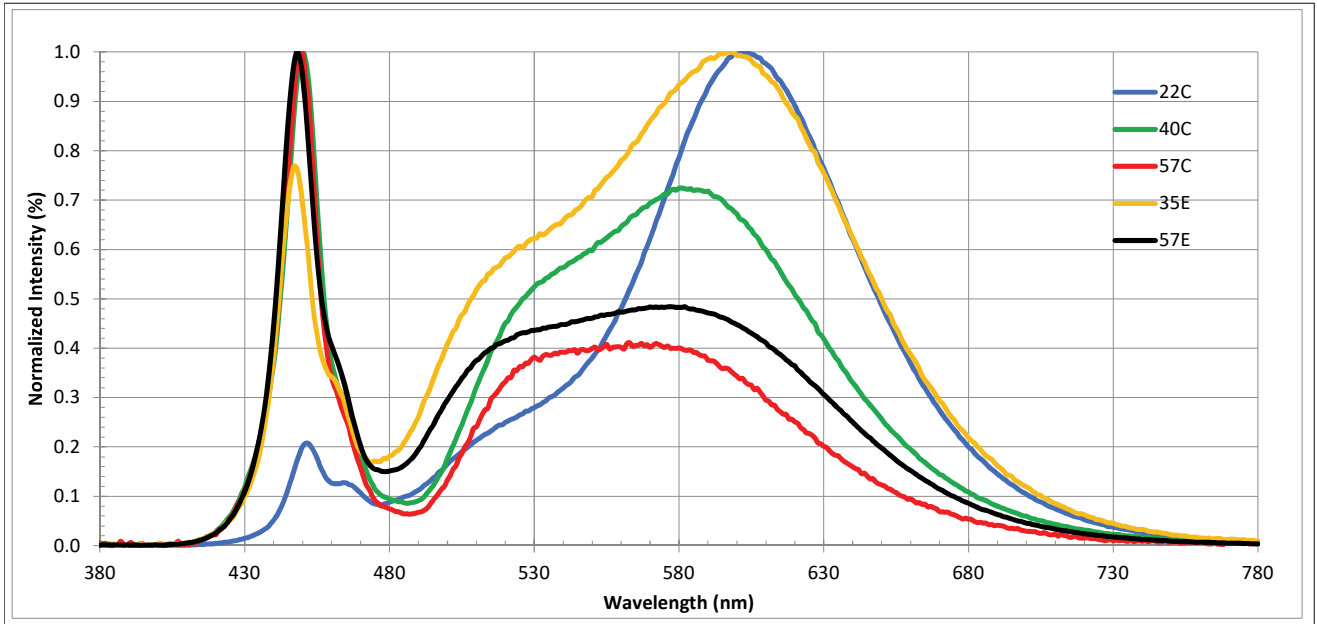

Notes for Figure 10:

1. Color spectra measured at nominal current for $T_{sp} = 25^{\circ}\text{C}$
2. 22C spectra shown for warm white is 2200K and 70 CRI.
3. 40C spectra shown for neutral white is 4000K and 70 CRI.
4. 57C spectra shown for cool white is 5700K and 70 CRI.
5. 35E spectra shown for warm white is 3500K and 80 CRI.
6. 57E spectra shown for cool white is 5700K and 80 CRI.

Mechanical Dimensions

Figure 11: Drawing for SMD 5050

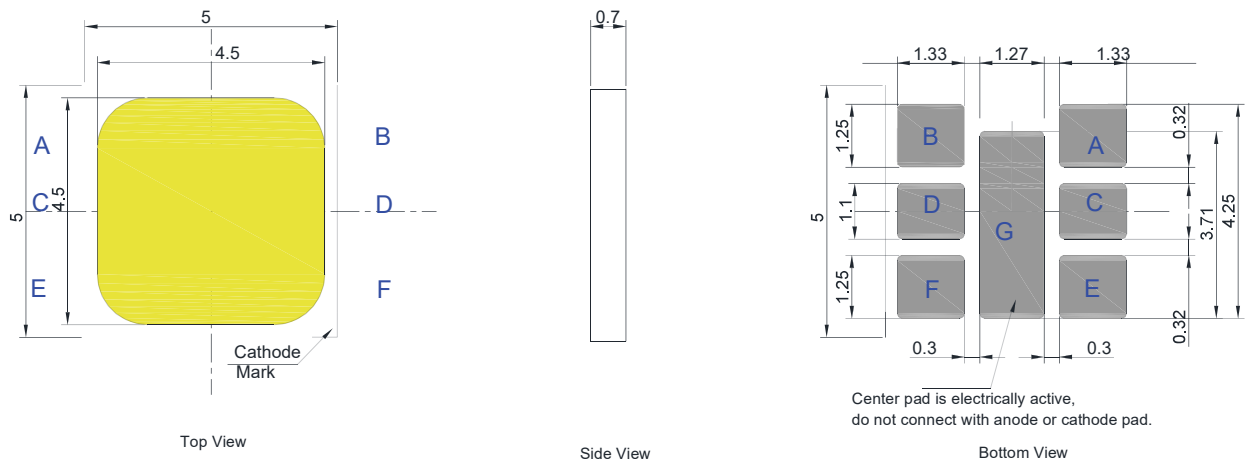

Center pad is electrically active, do not connect with anode or cathode pad.

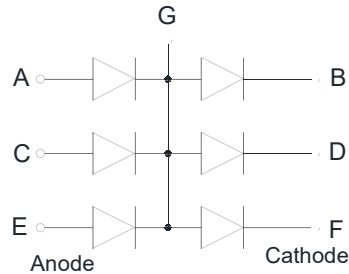

Equivalent Circuit

Notes for Figure 11:

1. Drawings are not to scale.
2. Drawing dimensions are in millimeters.
3. Unless otherwise specified, tolerances are $\pm 0.10\text{mm}$.

Recommended PCB Soldering Pad Pattern

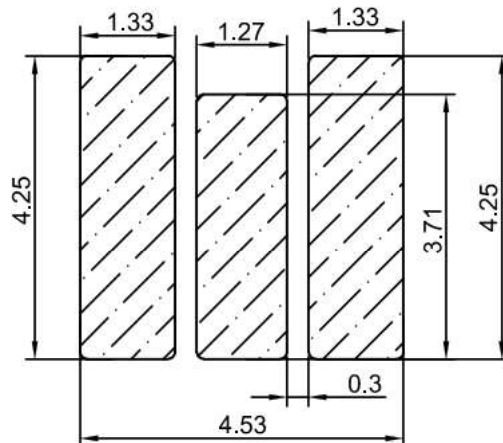

Reliability

Table 9: Reliability Test Items and Conditions

No .	Items	Reference Standard	Test Conditions	Drive Current	Test Duration	Units Failed/Tested
1	Moisture/Reflow Sensitivity	J-STD-020E	$T_{\text{slid}} = 260^{\circ}\text{C}$, 10sec. Precondition: 30°C , 60%RH, 168hr	-	3 reflows	0/20
2	Low Temperature Storage	JESD22-A119	$T_{\text{a}} = -40^{\circ}\text{C}$	-	1000 hours	0/20
3	High Temperature Storage	JESD22-A103D	$T_{\text{a}} = 105^{\circ}\text{C}$	-	1000 hours	0/20
4	Low Temperature Operating Life	JESD22-A108D	$T_{\text{a}} = -40^{\circ}\text{C}$	350mA	1000 hours	0/20
5	Temperature Humidity Operating Life	JESD22-A101C	$T_{\text{sp}} = 85^{\circ}\text{C}$, RH=85%	350mA	1000 hours	0/20
6	High Temperature Operating Life	JESD22-A108D	$T_{\text{sp}} = 105^{\circ}\text{C}$	750mA	1000 hours	0/20
7	Thermal Shock	JESD22-A106B	$T_{\text{a}} = -40^{\circ}\text{C} \sim 125^{\circ}\text{C}$; Dwell : 15min; Transfer: 10sec	-	200 cycles	0/20
8	Electrostatic Discharge	JS-001-2012	HBM, 2kV, 15k Ω , 100pF, Alternately positive or negative	-	-	0/20

Passing Criteria

Item	Symbol	Test Condition	Passing Criteria
Forward Voltage	Vf	350mA	$\Delta V_f < 10\%$
Luminous Flux	Fv	350mA	$\Delta F_v < 30\%$
Chromaticity Coordinates	(x, y)	350mA	$\Delta u'v' < 0.007$

Notes for Table 9:

- Measurements are performed after allowing the LEDs to return to room temperature
- T_{slid} : reflow soldering temperature; T_{a} : ambient temperature

Reflow Characteristics

Figure 12 : Reflow Profile

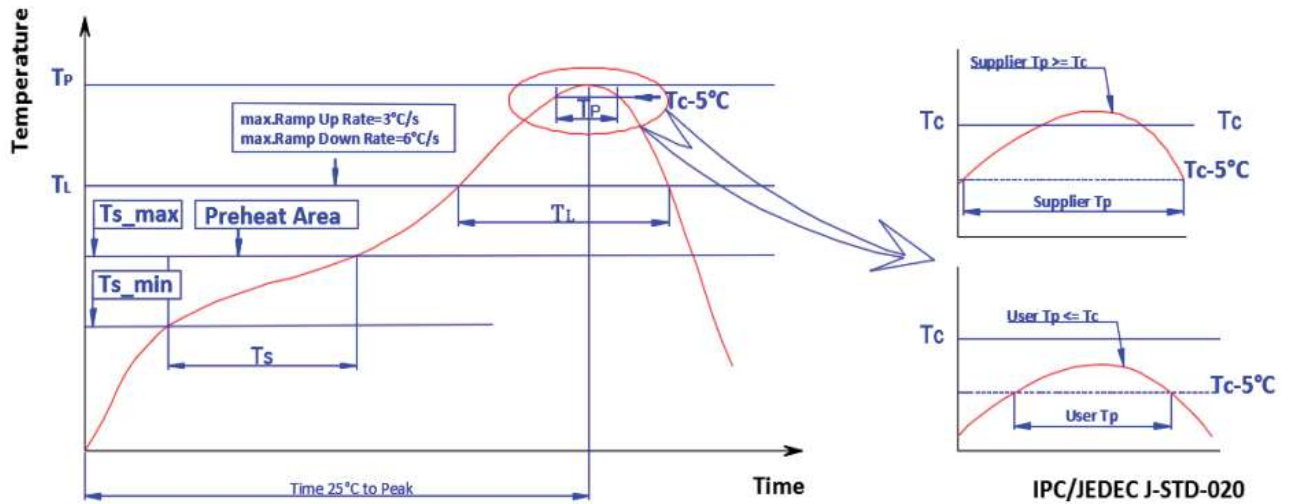

Profile Feature	Lead Free Assembly
Average Ramp-Up Rate (Ts max to Tp)	3/second max.
Preheat: Temperature Min (Ts min)	150
Preheat: Temperature Max (Ts max)	190
Preheat: Time (ts min to ts max)	90-120 seconds
Liquidous Temperature (TL)	217
Time Maintained Above Liquidous Temperature (TL): Time (tL)	60-90 seconds
Peak/Classification Temperature (Tp)	250-255
Time Within 10 of Actual Peak Temperature (Tp)	20-40 seconds
Ramp-Down Rate	6/second max
Time 25 to Peak Temperature	8 minutes max.

Caution:

1. The maximum number of reflow solderings do not exceed 2 times.
2. Repairs should not be done after the LEDs have been soldered. When repair is unavoidable, suitable tools must be used.

Packaging

Figure 13: Emitter Reel Drawings

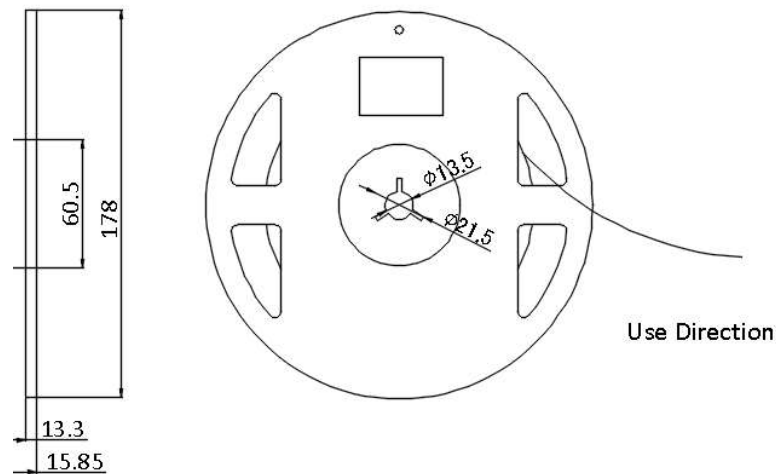

Note for Figure 13:
1. Drawings are not to scale. Drawing dimensions are in millimeters.

Figure 14: Emitter Tape Drawings

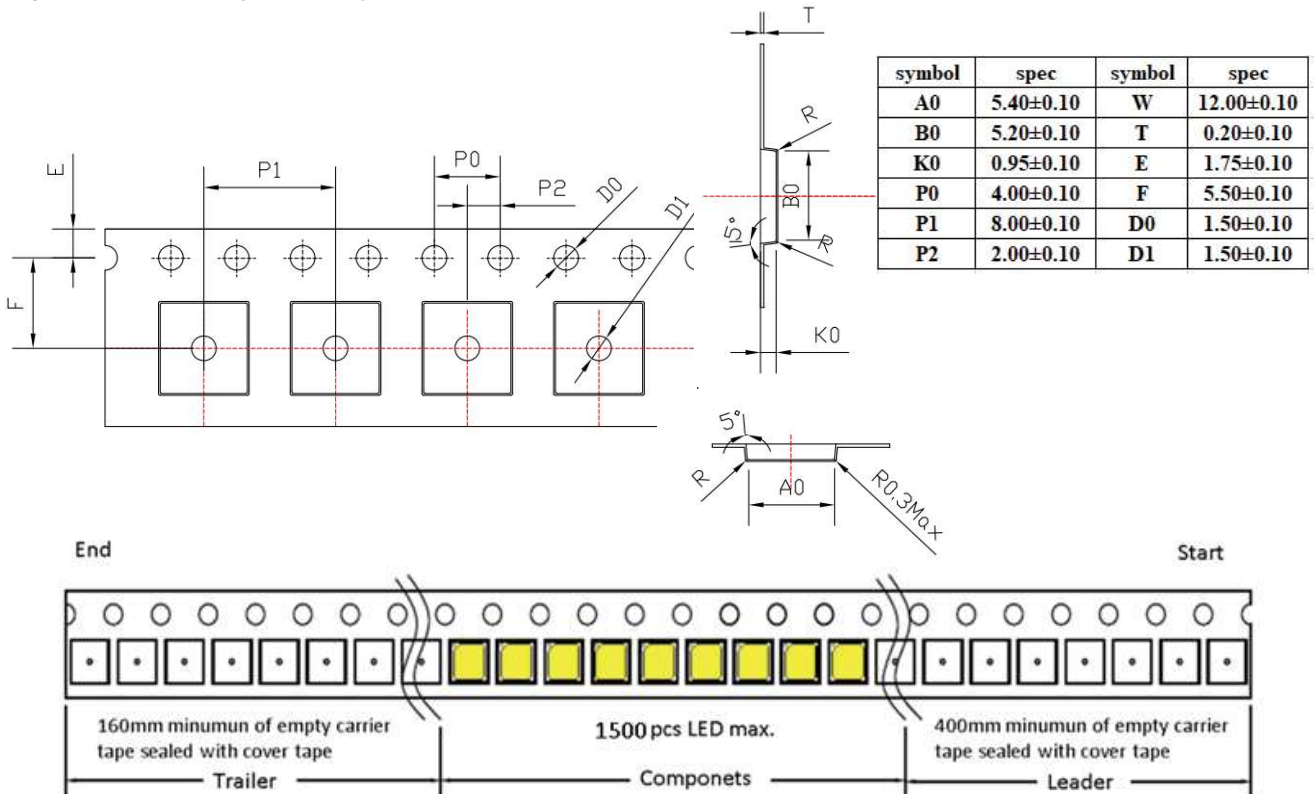

Note for Figure 14:
1. Drawings are not to scale. Drawing dimensions are in millimeters.

Packaging

Figure 15: Emitter Reel Packaging Drawings

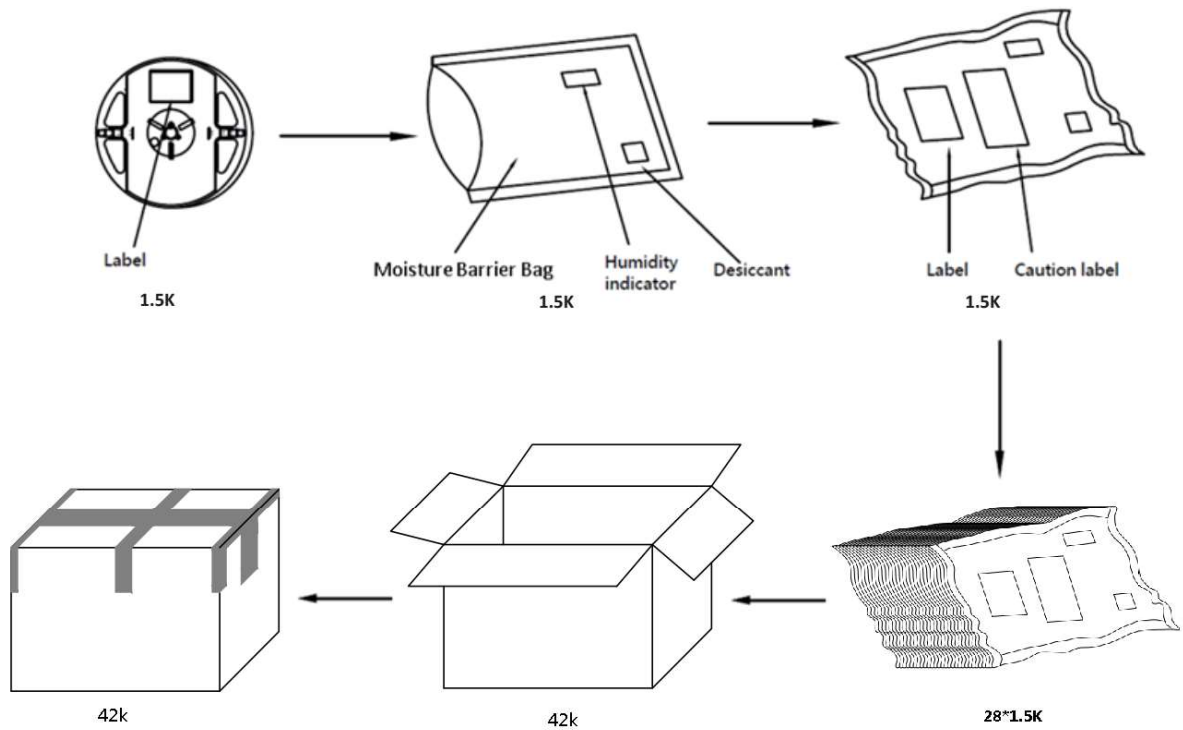

Note for Figure 15:

1. Drawings are not to scale.

Design Resources

Please contact your Bridgelux sales representative for assistance.

Precautions

CAUTION: CHEMICAL EXPOSURE HAZARD

Exposure to some chemicals commonly used in luminaire manufacturing and assembly can cause damage to the LED emitter. Please consult Bridgelux Application Note AN51 for additional information.

CAUTION: EYE SAFETY

Eye safety classification for the use of Bridgelux SMD LED emitter is in accordance with IEC specification EN62471: Photobiological Safety of Lamps and Lamp Systems. SMD LED emitters are classified as Risk Group 2 when operated at or below the maximum drive current. Please use appropriate precautions. It is important that employees working with LEDs are trained to use them safely.

CAUTION: RISK OF BURN

Do not touch the SMD LED emitter during operation. Allow the emitter to cool for a sufficient period of time before handling. The SMD LED emitter may reach elevated temperatures such that could burn skin when touched.

CAUTION

CONTACT WITH LIGHT EMITTING SURFACE (LES)

Avoid any contact with the LES. Do not touch the LES of the emitter or apply stress to the LES (yellow phosphor resin area). Contact may cause damage to the emitter

Optics and reflectors must not be mounted in contact with the LES (yellow phosphor resin area).

Disclaimers

MINOR PRODUCT CHANGE POLICY

The rigorous qualification testing on products offered by Bridgelux provides performance assurance. Slight cosmetic changes that do not affect form, fit, or function may occur as Bridgelux continues product optimization.

STANDARD TEST CONDITIONS

Unless otherwise stated, LED emitter testing is performed at the nominal drive current.

About Bridgelux: Bridging Light and Life™

At Bridgelux, we help companies, industries and people experience the power and possibility of light. Since 2002, we've designed LED solutions that are high performing, energy efficient, cost effective and easy to integrate. Our focus is on light's impact on human behavior, delivering products that create better environments, experiences and returns—both experiential and financial. And our patented technology drives new platforms for commercial and industrial luminaires.

For more information about the company, please visit
bridgelux.com
twitter.com/Bridgelux
facebook.com/Bridgelux
youtube.com/user/Bridgelux
https://www.linkedin.com/company/bridgelux-inc-_2
WeChat ID: BridgeluxInChina



46410 Fremont Boulevard
Fremont, CA 94538, USA
Tel (925) 583-8400
www.bridgelux.com

© 2025 Bridgelux, Inc. All rights reserved 2025. Product specifications are subject to change without notice. Bridgelux and the Bridgelux stylized logo design are registered trademarks of Bridgelux, Inc. All other trademarks are the property of their respective owners.