

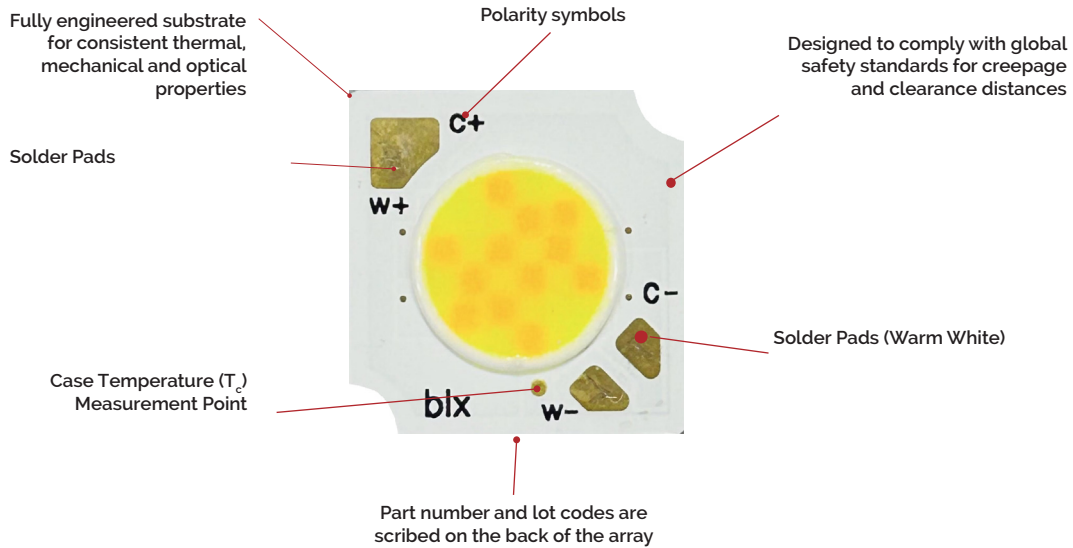
# Bridgelux® Vesta® Series Tunable White HD TW 6mm Array, 90 CRI and Thrive™

Product Data Sheet DS1751



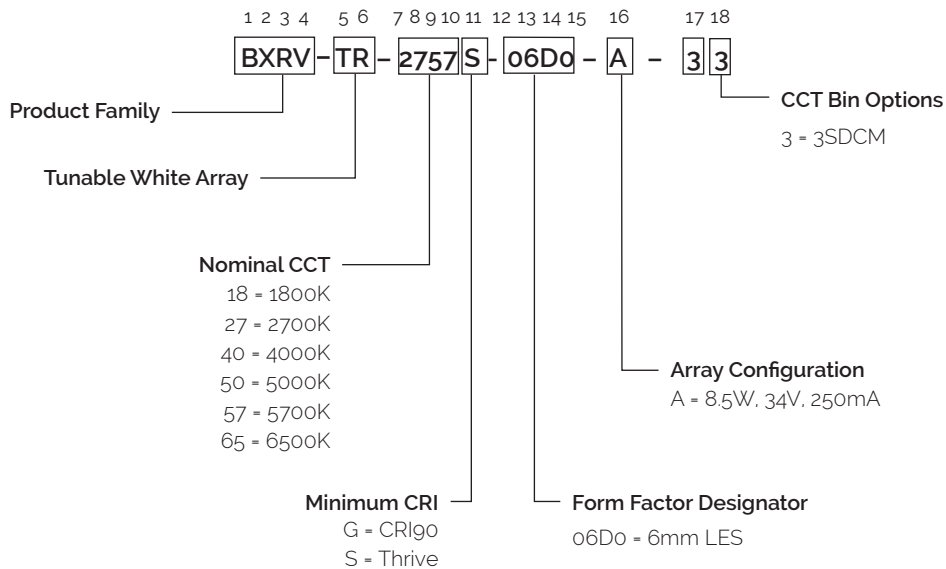
# Product Feature Map

Bridgelux arrays are fully engineered devices that provide consistent thermal and optical performance on an engineered mechanical platform. The arrays incorporate several features to simplify design integration and assembly. Please visit [www.bridgelux.com](http://www.bridgelux.com) for more information on the Vesta Series family of products.



## Product Nomenclature

The part number designation for Bridgelux Vesta Series arrays is explained as follows:



# Product Selection Guide

The following product configurations are available:

**Table 1:** Selection Guide, Measurement Data ( $T_j = T_c = 25^\circ\text{C}$ )

Part Number	Nominal CCT <sup>1</sup> $T_c=25^\circ\text{C}$ (K)	Typical CRI <sup>2</sup> $T_c=25^\circ\text{C}$	Nominal Drive Current per channel (mA)	Typical $V_f$ <sup>3</sup> $T_c=25^\circ\text{C}$ (V)	Typical Power $T_c=25^\circ\text{C}$ (W)	Typical Pulsed Flux <sup>3,4,5</sup> $T_c=25^\circ\text{C}$ (lm)	Typical Efficacy $T_c=25^\circ\text{C}$ <sup>5</sup> (lm/W)	Minimum Pulsed Flux $T_c=25^\circ\text{C}$ <sup>8</sup> (lm)
BXRV-TR-1840G-06D0-A-3X	1800	90	250	34.5	8.6	676	78	608
	4000	90	250	34.5	8.6	1021	118	919
BXRV-TR-2765G-06D0-A-3X	2700	90	250	34.2	8.5	866	101	779
	6500	90	250	34.2	8.5	1091	128	982
BXRV-TR-2750S-06D0-A-3X	2700	95,Thrive	250	34.4	8.6	710	83	639
	5000	95,Thrive	250	34.5	8.6	915	106	823
BXRV-TR-2757S-06D0-A-3X	2700	95,Thrive	250	34.4	8.6	710	83	639
	5700	97,Thrive	250	34.5	8.6	917	106	825

**Notes for Table 1:**

- Nominal CCT as defined by ANSI C78.377-2011.
- CRI values are minimums and tested at  $T_j = T_c = 25^\circ\text{C}$ . For 2700K CRI 95 Thrive products, the minimum CRI value is 93.5 and the minimum Rg value is 90. For 5700K CRI 97 Thrive products, the minimum CRI value is 95 and the minimum Rg value is 90. For CRI 90 products, the minimum CRI value is 90 and the minimum Rg value is 50. Bridgelux maintains a  $\pm 3$  tolerance on CRI values.
- Products tested under pulsed condition (10ms pulse width) at nominal test current where  $T_j$  (junction temperature) =  $T_c$  (case temperature) =  $25^\circ\text{C}$ .
- Typical performance values are provided as a reference only and are not a guarantee of performance.
- Bridgelux maintains a  $\pm 7\%$  tolerance on flux measurements.
- Typical stabilized DC performance values are provided as reference only and are not a guarantee of performance.
- Typical performance is estimated based on operation under DC (direct current) with LED array mounted onto a heat sink with thermal interface material and the case temperature maintained at  $85^\circ\text{C}$ . Based on Bridgelux test setup, values may vary depending on the thermal design of the luminaire and/or the exposed environment to which the product is subjected.
- Minimum flux values at pulsed nominal test current are guaranteed by 100% test.

# Product Selection Guide

The following product configurations are available:

**Table 2:** Selection Guide, Measurement Data ( $T_j = T_c = 85^\circ\text{C}$ )

Part Number	Nominal CCT <sup>1</sup> $T_c=85^\circ\text{C}$ (K)	Typical CRI <sup>2</sup> $T_c=85^\circ\text{C}$	Nominal Drive Current per channel (mA)	Typical $V_f$ <sup>3</sup> $T_c=85^\circ\text{C}$ (V)	Typical Power $T_c=85^\circ\text{C}$ (W)	Typical Pulsed Flux <sup>3,4,5</sup> $T_c=85^\circ\text{C}$ (lm)	Typical Efficacy $T_c=85^\circ\text{C}$ <sup>5</sup> (lm/W)	Minimum Pulsed Flux $T_c=85^\circ\text{C}$ <sup>8</sup> (lm)
BXRV-TR-1840G-06D0-A-3X	1800	90	250	33.3	8.3	576	69	518
	4000	90	250	33.3	8.3	880	106	792
BXRV-TR-2765G-06D0-A-3X	2700	90	250	33.1	8.3	753	91	677
	6500	90	250	33.1	8.3	950	115	855
BXRV-TR-2750S-06D0-A-3X	2700	96.5,Thrive	250	32.8	8.2	619	75	557
	5000	97,Thrive	250	33.2	8.3	807	97	726
BXRV-TR-2757S-06D0-A-3X	2700	96.5,Thrive	250	32.8	8.2	619	75	557
	5700	97,Thrive	250	33.2	8.3	809	97	728

**Notes for Table 2:**

- Nominal CCT as defined by ANSI C78.377-2011.
- CRI values are minimums and tested at  $T_j = T_c = 85^\circ\text{C}$ . For 2700K CRI 96.5 Thrive products, the minimum CRI value is 95 and the minimum Rg value is 90. For 5700k CRI 97 Thrive products, the minimum CRI value is 95 and the minimum Rg value is 90. For CRI 90 products, the minimum CRI value is 90 and the minimum Rg value is 50. Bridgelux maintains a  $\pm 3$  tolerance on CRI values.
- Products tested under pulsed condition (10ms pulse width) at nominal test current where  $T_j$  (junction temperature) -  $T_c$  (case temperature) =  $85^\circ\text{C}$ .
- Typical performance values are provided as a reference only and are not a guarantee of performance.
- Bridgelux maintains a  $\pm 7\%$  tolerance on flux measurements.
- Typical stabilized DC performance values are provided as reference only and are not a guarantee of performance.
- Typical performance is estimated based on operation under DC (direct current) with LED array mounted onto a heat sink with thermal interface material and the case temperature maintained at  $85^\circ\text{C}$ . Based on Bridgelux test setup, values may vary depending on the thermal design of the luminaire and/or the exposed environment to which the product is subjected.
- Minimum flux values at pulsed nominal test current are guaranteed by 100% test.

# European Product Registry for Energy Labeling

The European Product Registry for Energy Labeling (EPREL) is defined in the EU Regulation 2017/1369 to provide information about a product's energy efficiency to consumers. Together with Energy Labeling Regulation ELR (EU) 2019/2015, which was amended by regulation (EU) 2021/340 for energy labelling of light sources, manufacturers are required to declare an energy class based on key technical specifications from each of their product and register it in an open data base managed by EPREL. It is now a legal requirement for a vendor of light sources to upload information about their products into the EPREL database before placing these products on the market in the EU.

Table 3 provides a list of part numbers that are in compliance with EPREL regulations and are currently listed in the EPREL database.

At Bridgelux, we are fully committed to supplying products that are compliant with pertinent laws, rules, and obligation imposed by relevant government bodies including the ELR regulation. Customers can use these products with full confidence for any projects that fall under the EPREL requirement.

**Table 3:** Table of products registered in the European Product Registry for Energy Labeling (EPREL)

Part Number	CCT (K)	CRI	Current <sup>3</sup> (mA)	Voltage <sup>3</sup> (V)	Useful Flux <sup>2</sup> $\Phi_{\text{useful}}$ Tc=85°C (lm)	Power (W)	Efficacy (lm/W)	Energy Efficiency Class <sup>4</sup>	Registration No	URL <sup>1</sup>
BXRV-TR-1840G-06D0-A-3X										
BXRV-TR-2750S-06D0-A-33	5000	97	300	32.43	901	10	92.6	F	2229666	<a href="https://eprelec.europa.eu/qr/2229666">https://eprelec.europa.eu/qr/2229666</a>
BXRV-TR-2757S-06D0-A-33	5700	97	310	32.55	940	10	93.1	F	1848658	<a href="https://eprelec.europa.eu/qr/1848658">https://eprelec.europa.eu/qr/1848658</a>
BXRV-TR-2765G-06D0-A-33	6500	90	400	33.69	1487	13	110.3	F	2229667	<a href="https://eprelec.europa.eu/qr/2229667">https://eprelec.europa.eu/qr/2229667</a>

Notes for Table 3:

1. The performance data in this table is a subset of the data that was submitted to EPREL for obtaining the energy class listed here. For accessing a complete set of technical documentation of Bridgelux registered products in the EPREL database, please visit one of the hyperlinks listed above.
2. For a definition of useful luminous flux ( $\Phi_{\text{useful}}$ ), please see the ELR regulations at <https://tinyurl.com/4b6zvt4m>.
3. For information on performance values at alternative drive conditions, please refer to the Product Selection Guide, Absolute Maximum Rating Table and Performance Curves in this data sheet.
4. EPREL requires a symbol for displaying the energy classification of a product in marketing literature. This symbol consists of a letter stating a product's energy efficiency class inside a specific arrow logo as defined by EPREL.
5. All products listed here must be disposed as e-waste according to the guidelines in the country in which the product is used.

# CRI and TM30 Characteristics for Vesta Arrays with Thrive

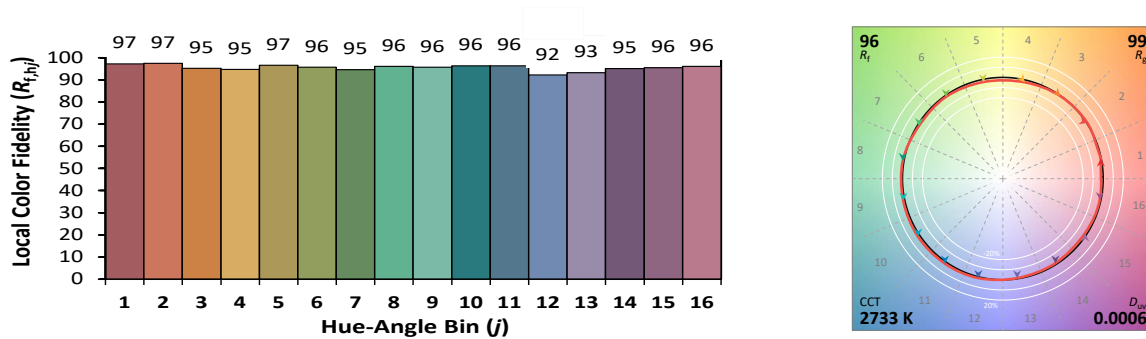
**Table 4:** Typical Color Rendering Index and TM-30 Values at  $T_c=85^\circ\text{C}$

Nominal CCT <sup>1</sup>	R <sub>f</sub>	R <sub>g</sub>	R <sub>a</sub>	R <sub>1</sub>	R <sub>2</sub>	R <sub>3</sub>	R <sub>4</sub>	R <sub>5</sub>	R <sub>6</sub>	R <sub>7</sub>	R <sub>8</sub>	R <sub>9</sub>	R <sub>10</sub>	R <sub>11</sub>	R <sub>12</sub>	R <sub>13</sub>	R <sub>14</sub>	R <sub>15</sub>
2700K	95	98	96.5	95	96	96	95	95	94	97	97	93	93	92	91	95	96	96
5000K	95	98	97	95	95	95	95	95	95	96	95	91	92	92	92	95	95	95
5700K	95	98	97	96	96	96	96	96	96	96	97	92	93	93	92	96	97	95

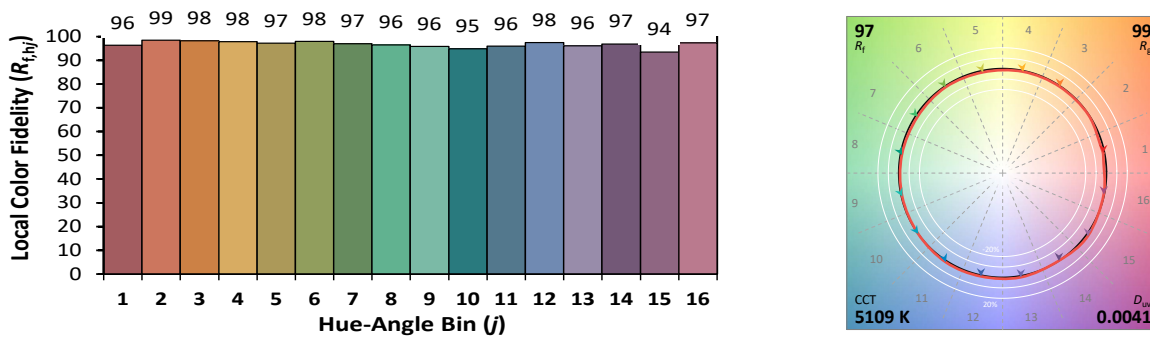
Note for Table 4:

1. Applicable for part numbers BXRV-TR-xxxxS-06Do-A-3x with the Thrive spectrum
2. Bridgelux maintains a tolerance of  $\pm 3$  on Color Rendering Index R1-R15 measurements and TM-30 measurements.

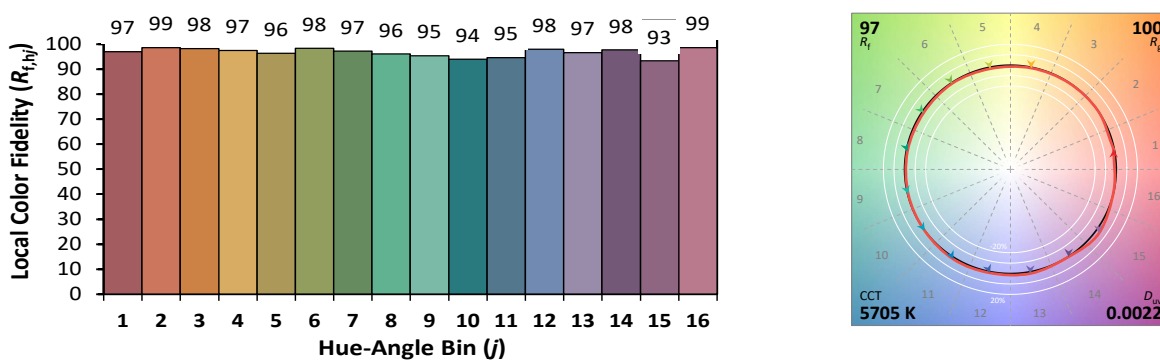
**Figure 1: 2700K Thrive TM-30 Graphs at  $T_c=85^\circ\text{C}$**



**Figure 2: 5000K Thrive TM-30 Graphs at  $T_c=85^\circ\text{C}$**



**Figure 3: 5700K Thrive TM-30 Graphs at  $T_c=85^\circ\text{C}$**



# Average Spectral Difference

## Spectral Matching to Natural Light

The lighting market is in the early stages of adoption of human-centric lighting (HCL). HCL encompasses the effects of lighting on the physical and emotional health and well-being of people. Throughout evolution, the human visual system has evolved under the natural light of sun and fire. These light sources have standardized industry spectral power definitions that describe the state of natural light. However, conventional metrics such as CCT, CRI, and TM-30 fail to adequately quantify the naturalness, or closeness of these light sources to the standardized natural spectra. Due to a lack of an industry standard metric to quantitatively measure the naturalness of a light source, Bridgelux has pioneered a new metric that takes the guesswork out of comparing LED light sources to natural light.

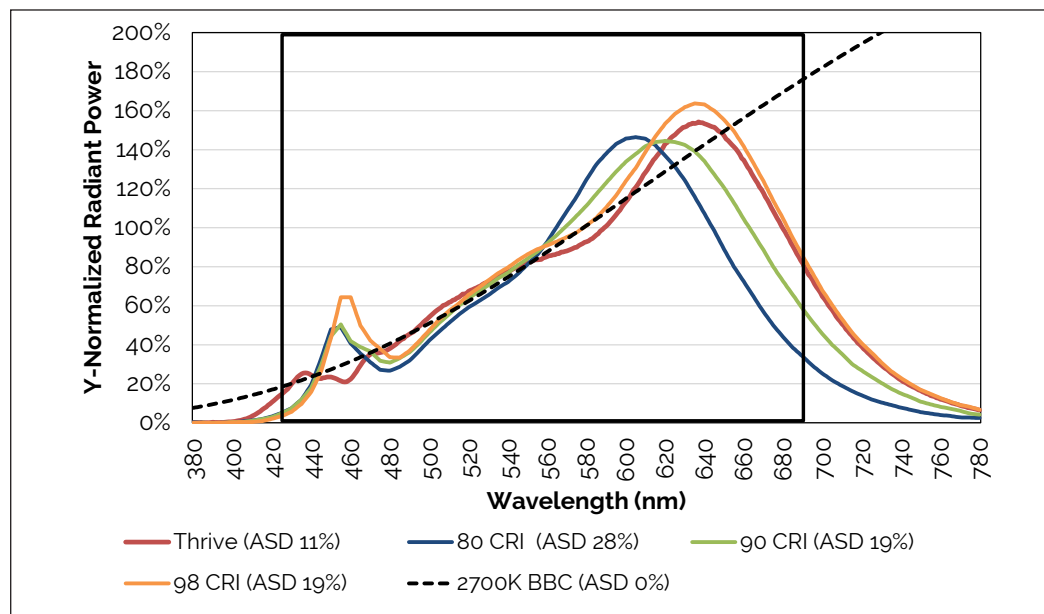
Average Spectral Difference, or ASD, is calculated by measuring the absolute difference between two spectra at discrete wavelengths. These values are averaged across a wavelength range derived from the photopic response curve, or  $V(\lambda)$ ; a luminous efficiency function describing the average spectral sensitivity of human perception of brightness. The range of 425nm to 690nm was selected to remove the tails of the  $V(\lambda)$  gaussian distribution below 1% of the peak value at 555nm, covering 99.9% of the area under the photopic response curve. Natural light is defined following the approach of IES TM-30; black body curves for light sources of  $\leq 4000K$  and the CIE standard illuminant D for light sources of  $\geq 5000K$ .

Natural light has an ASD of 0%; lower ASD values indicate a closer match to natural light. Thrive is engineered to provide the closest match to natural light available using proprietary chip, phosphor and packaging technology, resulting in an ASD between 8% to 11% for all CCTs used in Vesta products. By comparison, standard 80, 90, and 98 CRI light sources have ASD values that are 100% to 300% larger than Thrive. To learn more about the ASD metric, please review the Bridgelux whitepaper: Average Spectral Difference, a new method to make objective comparisons of naturalness between light sources; or contact your Bridgelux sales representative.

**Table 5:** Typical ASD Values at thrive spectrum  $T_c=85^\circ C$

Nominal CCT	ASD
2700K	9%
5000K	11%
5700K	11%

**Figure 4: SPD Comparison**



# Electrical Characteristics

**Table 6:** Electrical Characteristics

Part Number	CCT Channel (K)	Nominal Drive Current (mA)	Forward Voltage Pulsed, $T_c = 25^\circ\text{C}$ (V) <sup>1,2,3</sup>			Typical Temperature Coefficient of Forward Voltage <sup>4</sup> $\Delta V_f / \Delta T_c$ (mV/ $^\circ\text{C}$ )	Driver Selection Voltages <sup>6</sup> (V)	
			Minimum	Typical	Maximum		$V_f$ Min. Hot $T_c = 105^\circ\text{C}$ (V)	$V_f$ Max. Cold $T_c = -40^\circ\text{C}$ (V)
BXRV-TR-1840G-06D0-A-3X	1800	250	32.4	34.5	36.6	-14.4	31.3	37.5
	4000	250	32.4	34.5	36.6	-14.4	31.3	37.5
BXRV-TR-2765G-06D0-A-3X	2700	250	32.1	34.2	36.2	-14.4	31.0	37.2
	6500	250	32.1	34.2	36.2	-15.5	31.0	37.2
BXRV-TR-xxxxS-06D0-A-3X	2700	250	32.3	34.4	36.5	-14.0	31.2	37.4
	5000/5700	250	32.4	34.5	36.6	-14.1	31.4	37.5

Notes for Table 6:

1. Parts are tested in pulsed conditions,  $T_c = 25^\circ\text{C}$ . Pulse width is 10ms.
2. Voltage minimum and maximum are provided for reference only and are not a guarantee of performance.
3. Bridgelux maintains a tester tolerance of  $\pm 0.10\text{V}$  on forward voltage measurements.
4. Typical temperature coefficient of forward voltage tolerance is  $\pm 0.1\text{mV}$  for nominal current.
5. Thermal resistance value was calculated using total electrical input power; optical power was not subtracted from input power. The thermal interface material used during testing is not included in the thermal resistance value.
6.  $V_f$  min hot and max cold driver selection voltages are provided as reference only and are not guaranteed by test. These values are provided to aid in driver design and selection over the operating range of the product.

# Absolute Maximum Ratings

**Table 7:** Maximum Ratings

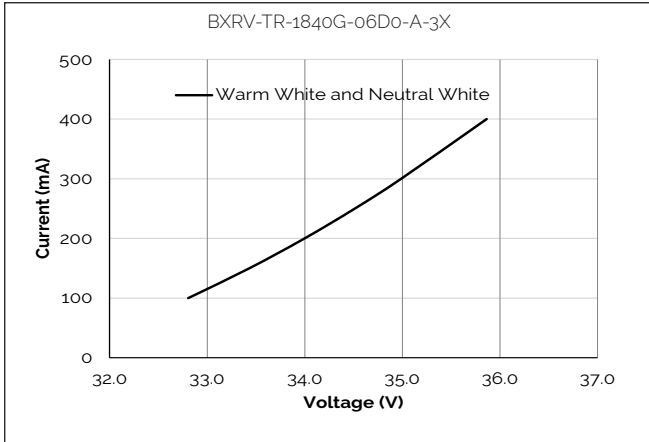
Parameter	Maximum Rating	
LED Junction Temperature ( $T_j$ )	125°C	
Storage Temperature	-40°C to +105°C	
Operating Case Temperature <sup>1,2</sup> ( $T_c$ )	105°C	
Soldering Temperature <sup>3</sup>	350°C or lower for a maximum of 3 seconds with electric soldering iron	
	BXRV-TR-xxxxX-06D0-A-3X	
	Channel 1	Channel 2
	Warm White	Neutral/Cooler White
Maximum Combined Drive Current <sup>4</sup>	400mA	400mA
Maximum Peak Pulsed Drive Current <sup>5</sup>	570mA	570mA
Maximum Total Power	14.5W	

Notes for Table 7:

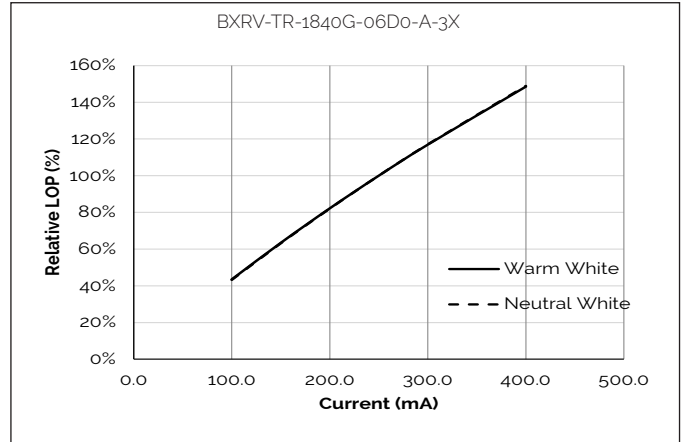
- For IEC 62717 requirement, please contact Bridgelux Sales Support.
- Refer to the Derating Curves for Current vs Case Temperature, Figures 29.
- See Bridgelux Application Note AN 92 for more information.
- The Maximum Combined Drive Current is defined as the sum of the drive currents in both channels.  
Example for BXRV-TR-2757S-06D0-A-3X: If 400mA is applied to one channel, no current may be applied to the other channel. If 250mA is applied to one channel, then a maximum of 150mA can be applied to the other channel.
- Bridgelux recommends a maximum duty cycle of 10% and pulse width of 20ms when operating LED arrays at the maximum peak pulsed current specified. Maximum peak pulsed currents indicate values where the LED array can be driven without catastrophic failures.

# Performance Curves

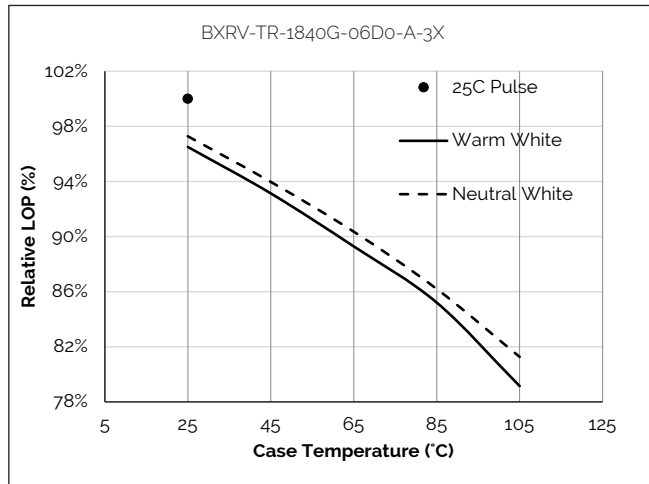
**Figure 5: Forward Voltage vs. Forward Current,  $T_c=25^\circ\text{C}$**



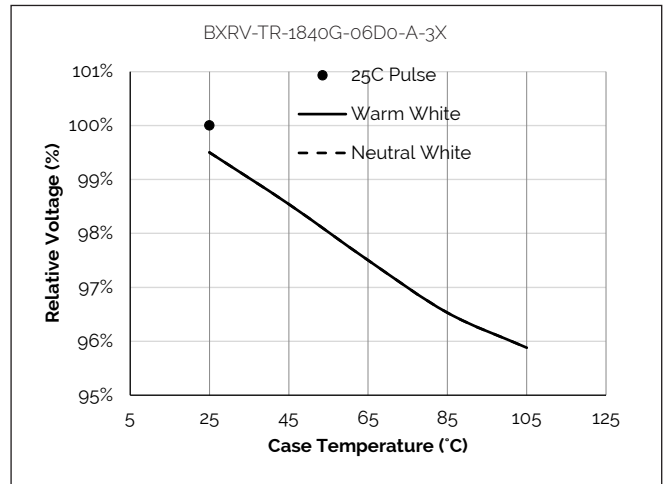
**Figure 6: Relative Flux vs. Drive Current,  $T_c=25^\circ\text{C}$**



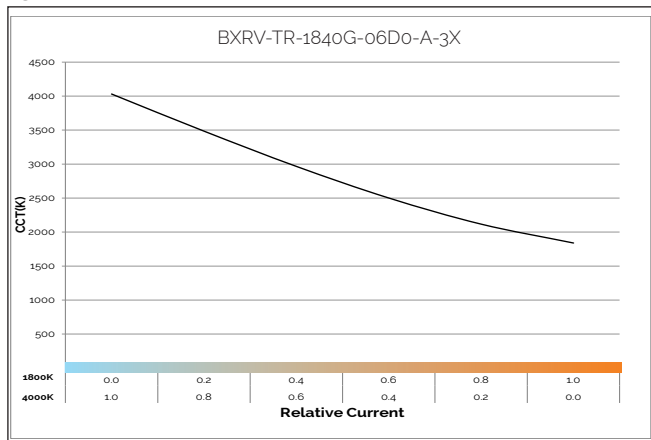
**Figure 7: Relative Flux vs. Case Temperature**



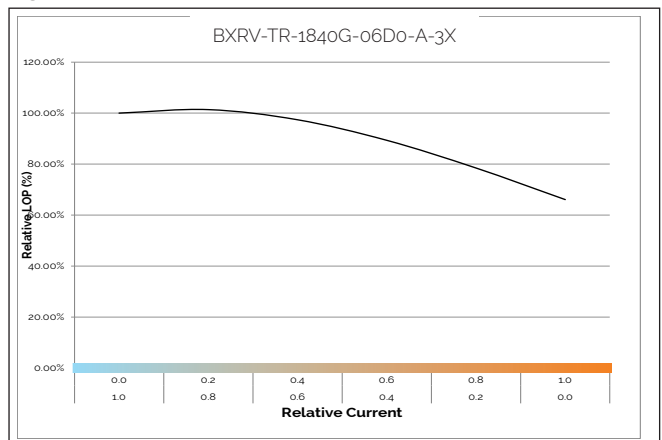
**Figure 8: Relative Voltage vs. Case Temperature**



**Figure 9: CCT vs. Relative Current,  $T_c=85^\circ\text{C}$**

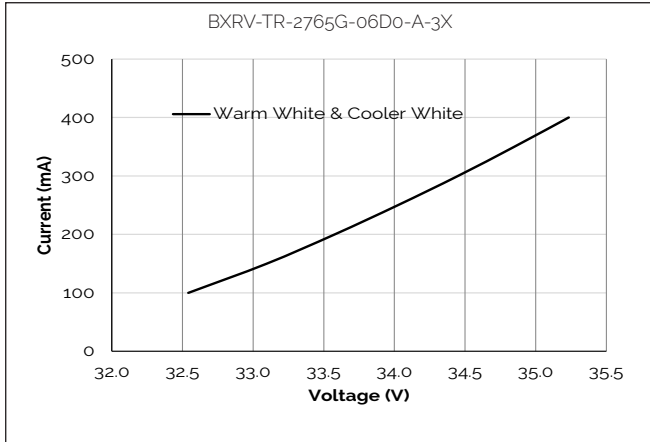


**Figure 10: Relative Flux vs. Relative Current**

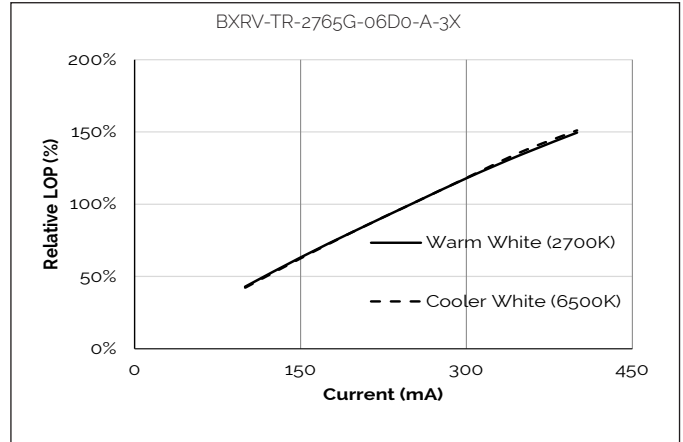


# Performance Curves

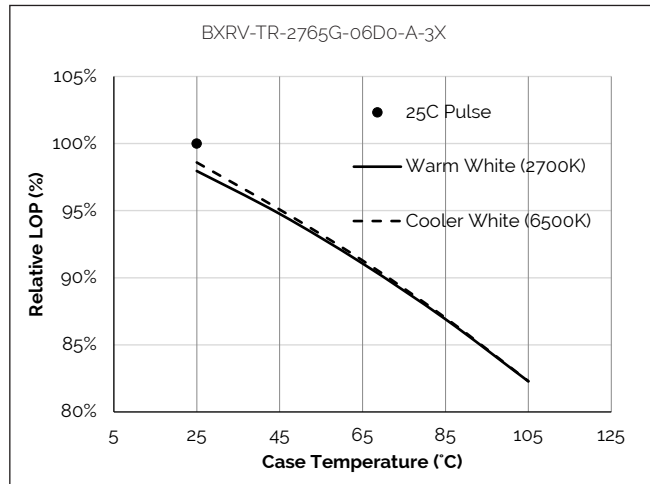
**Figure 11: Forward Voltage vs. Forward Current,  $T_c=25^\circ\text{C}$**



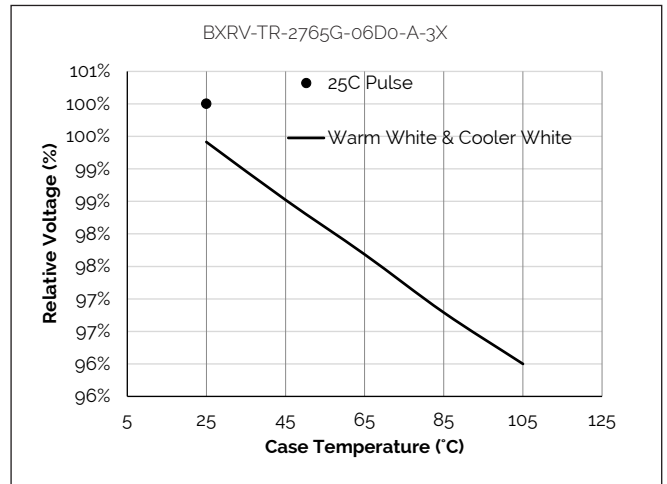
**Figure 12: Relative Flux vs. Drive Current,  $T_c=25^\circ\text{C}$**



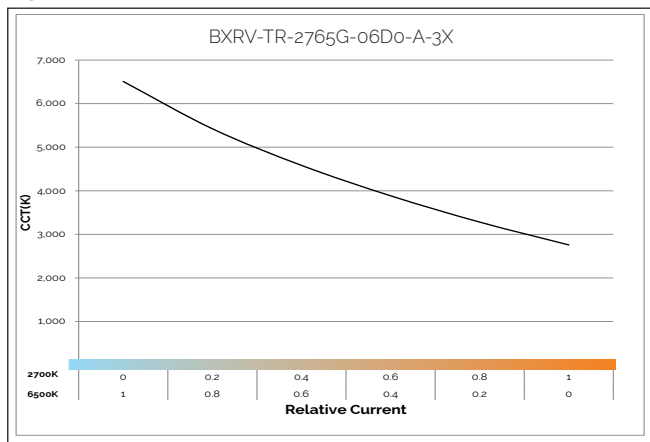
**Figure 13: Relative Flux vs. Case Temperature**



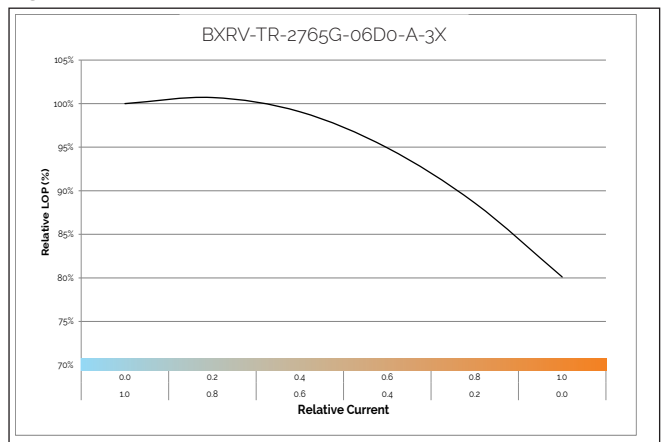
**Figure 14: Relative Voltage vs. Case Temperature**



**Figure 15: CCT vs. Relative Current,  $T_c=85^\circ\text{C}$**

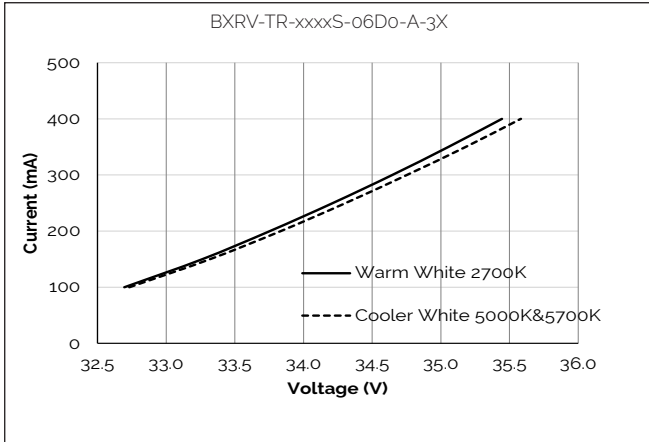


**Figure 16: Relative Flux vs. Relative Current**



# Performance Curves

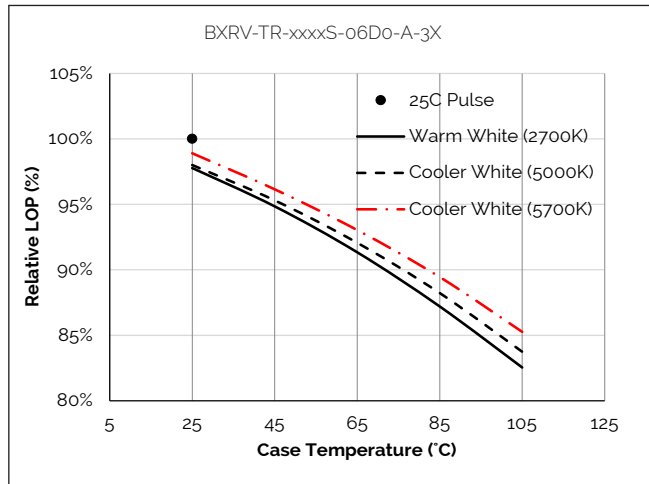
**Figure 17: Forward Voltage vs. Forward Current,  $T_c = 25^\circ\text{C}$**



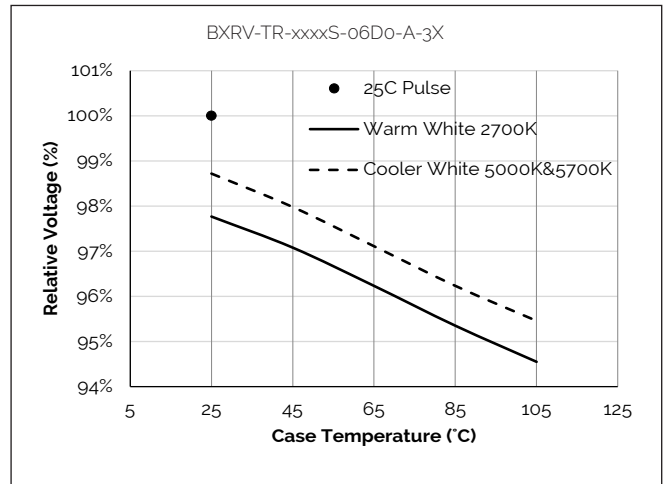
**Figure 18: Relative Flux vs. Drive Current,  $T_c = 25^\circ\text{C}$**



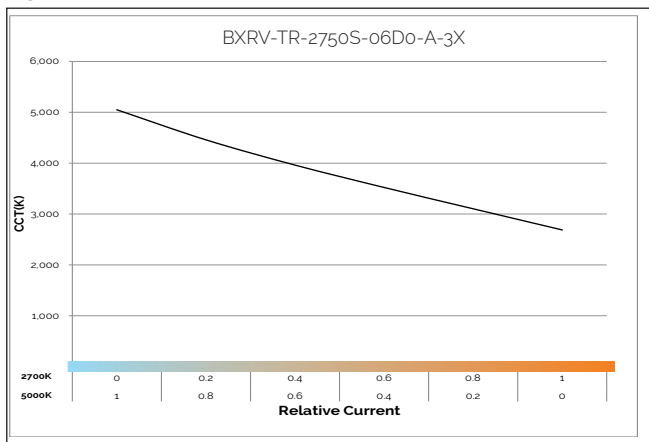
**Figure 19: Relative Flux vs. Case Temperature**



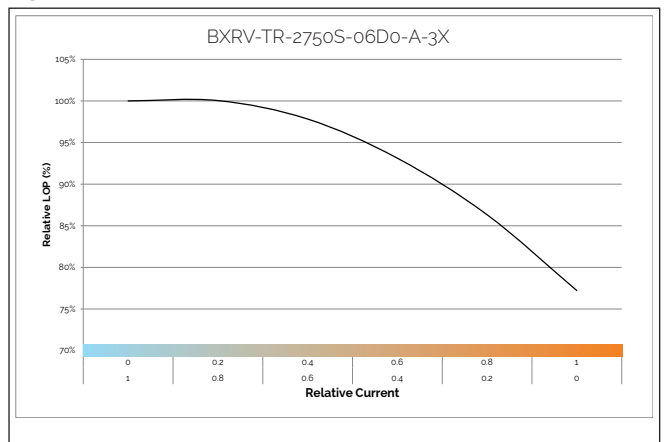
**Figure 20: Relative Voltage vs. Case Temperature**



**Figure 21: CCT vs. Relative Current,  $T_c = 85^\circ\text{C}$**

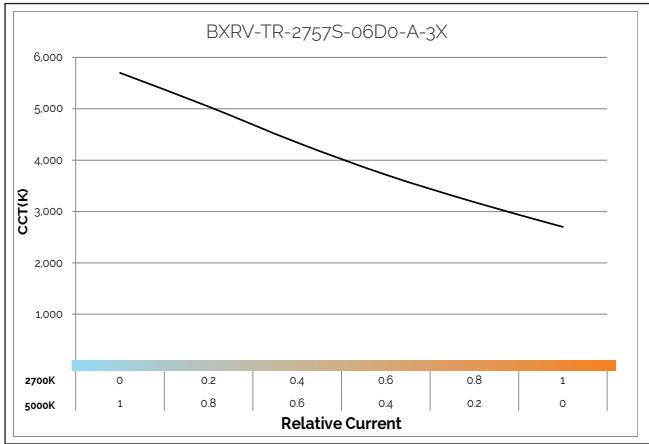


**Figure 22: Relative Flux vs. Relative Current**

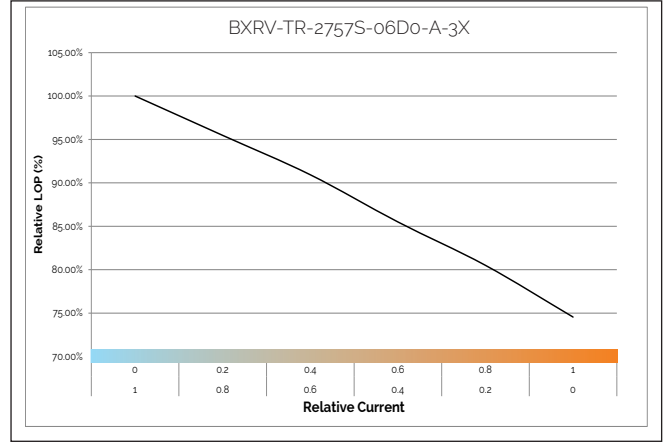


# Performance Curves

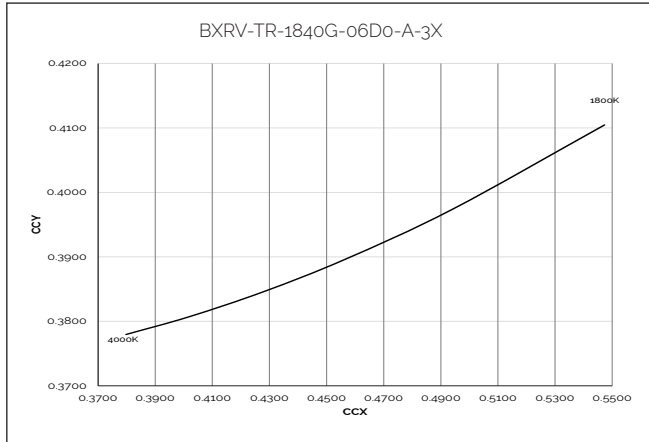
**Figure 23: CCT vs. Relative Current, Tc=85°C**



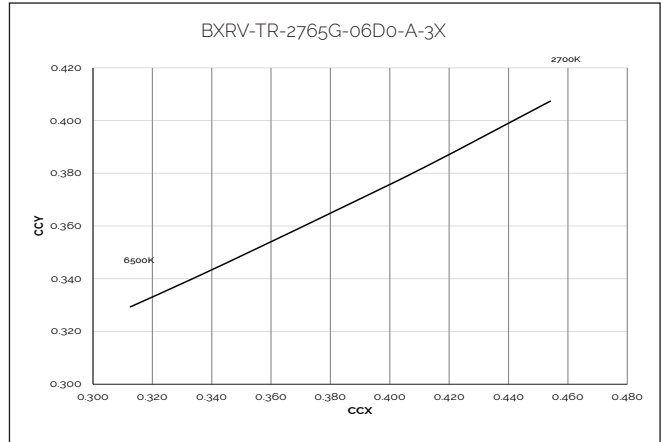
**Figure 24: Relative Flux vs. Relative Current**



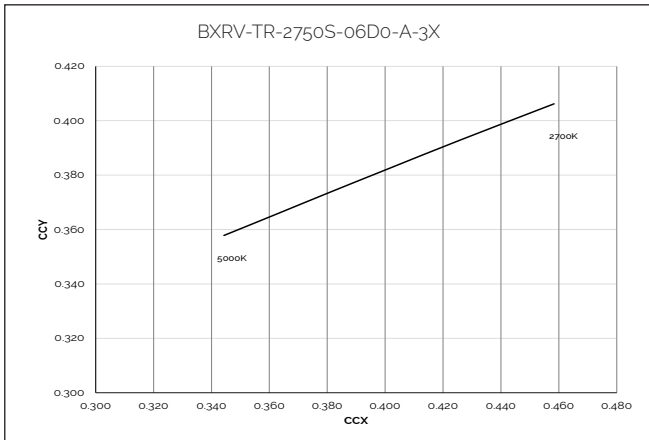
**Figure 25: CCT Tuning Range, Tc=85°C**



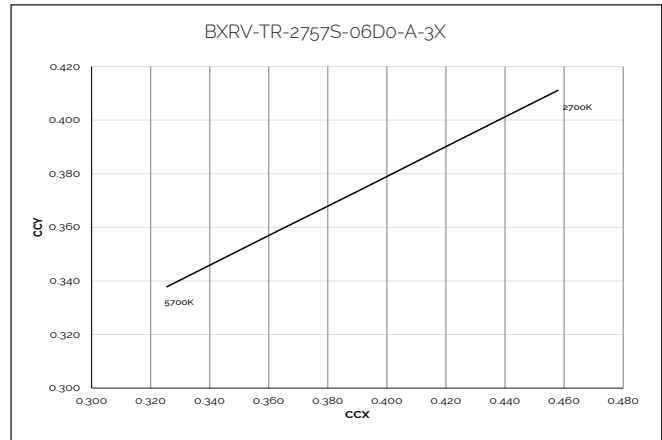
**Figure 26: CCT Tuning Range, Tc=85°C**



**Figure 27: CCT Tuning Range, Tc=85°C**

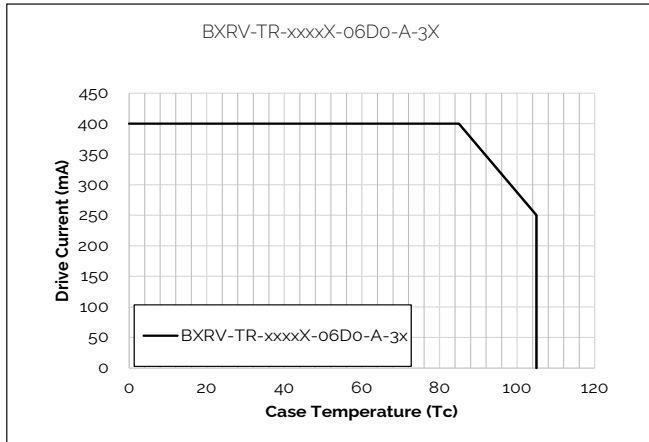


**Figure 28: CCT Tuning Range, Tc=85°C**



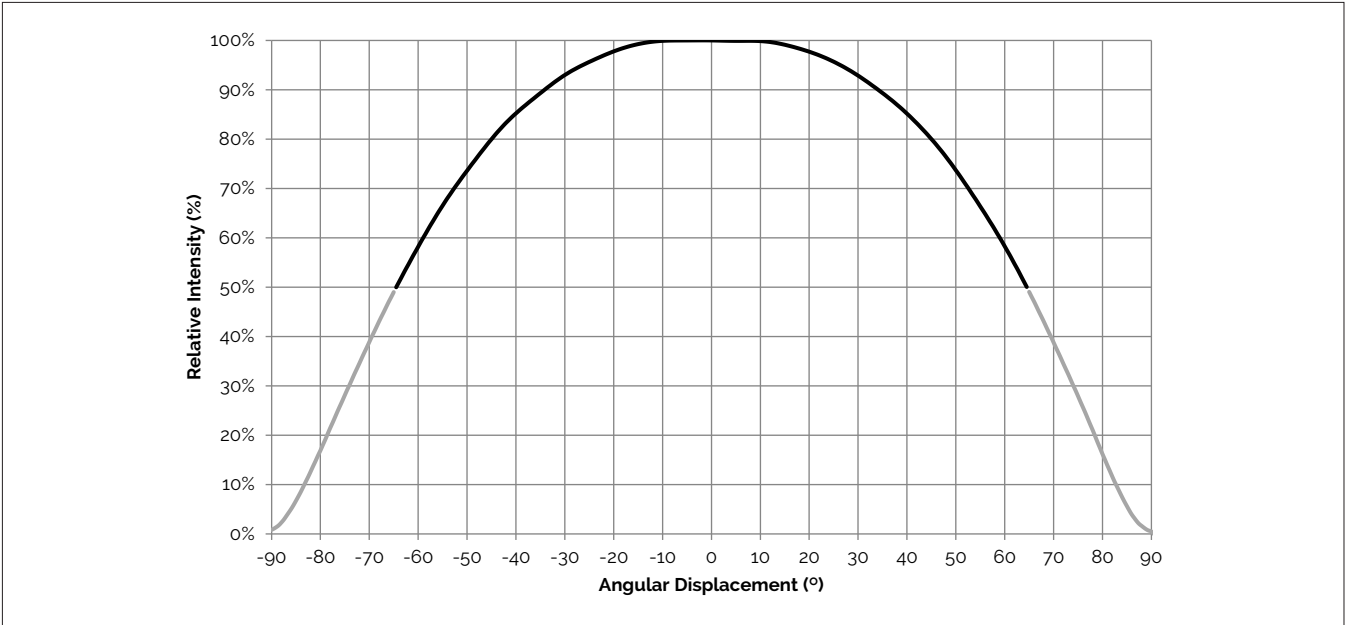
# Performance Curves

Figure 29: Derating Curve



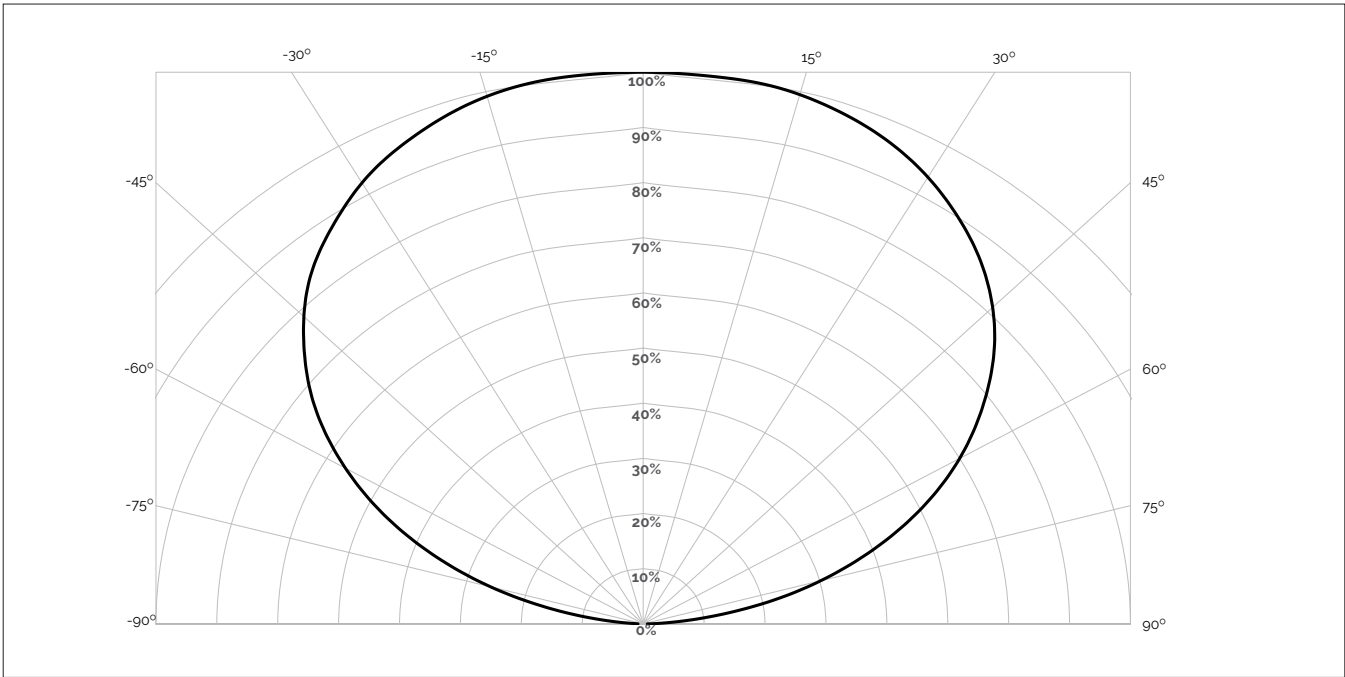
# Typical Radiation Pattern

Figure 30: Typical Spatial Radiation Pattern



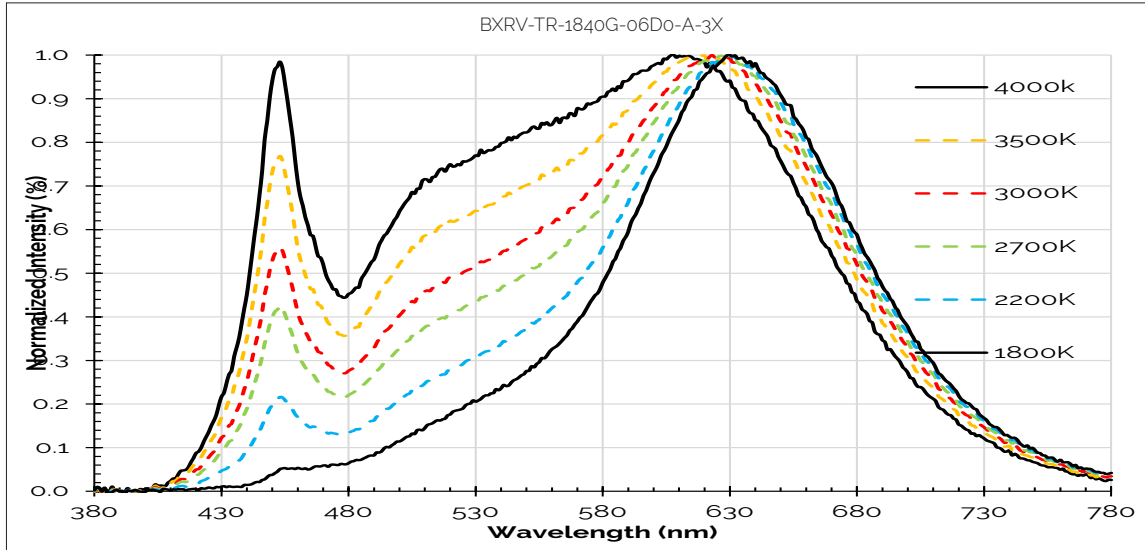
- Notes for Figure 30:
- 1. Typical viewing angle is 130°.
  - 2. The viewing angle is defined as the off axis angle from the centerline where Iv is ½ of the peak value.

Figure 31: Typical Polar Radiation Pattern



# Typical Color Spectrum

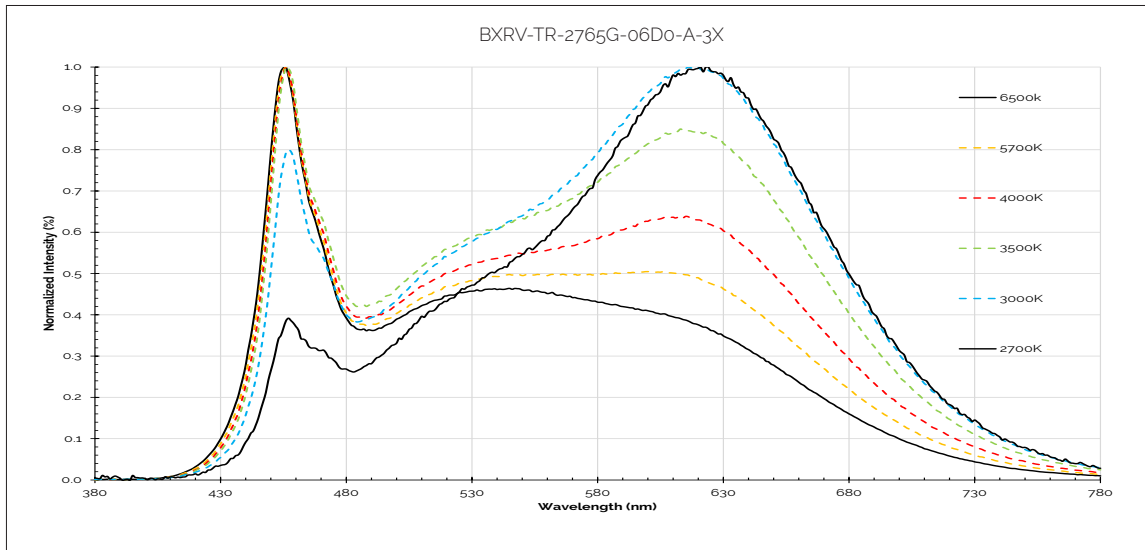
Figure 32: 1800K-4000K with CRI90



Note for Figure 32:

1. Color spectra measured at nominal current and  $T_c = 85^\circ\text{C}$ .

Figure 33: 2700K-6500K with CRI90

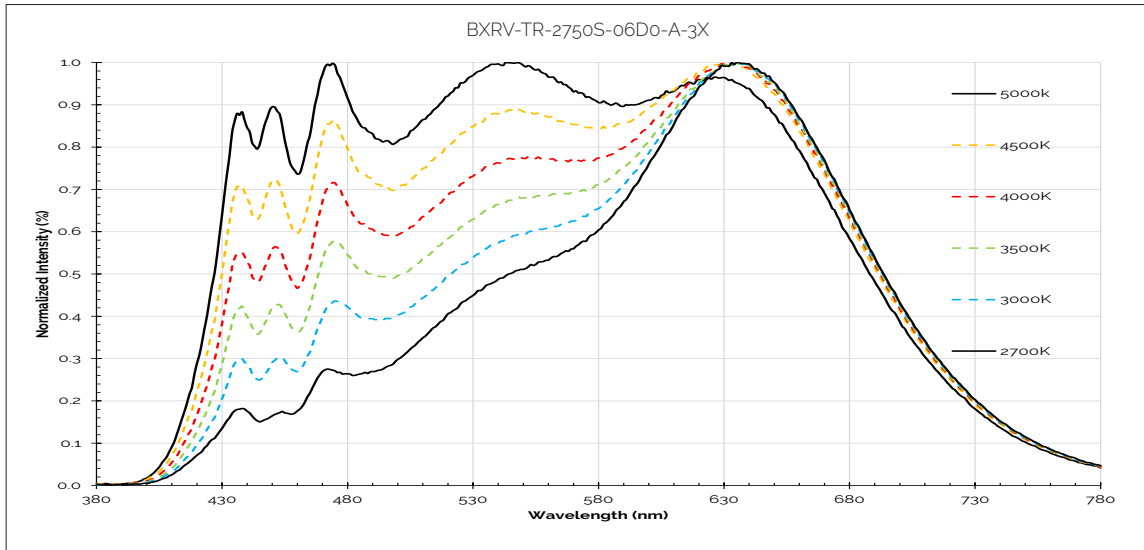


Note for Figure 33:

1. Color spectra measured at nominal current and  $T_c = 85^\circ\text{C}$ .

# Typical Color Spectrum

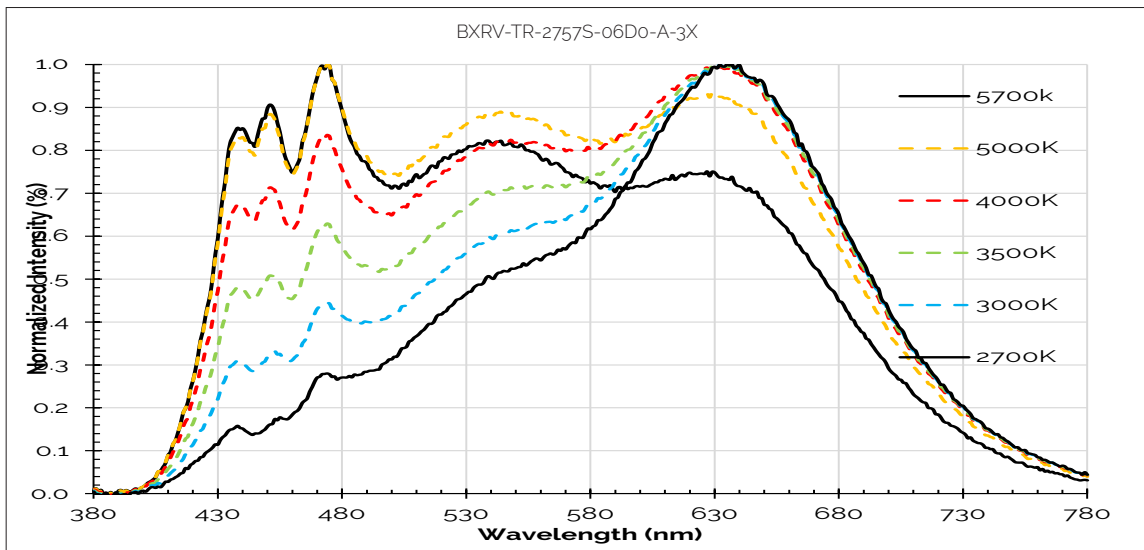
Figure 34: 2700K-5000K with Thrive



Note for Figure 34:

1. Color spectra measured at nominal current and  $T_c = 85^\circ\text{C}$ .

Figure 35: 2700K-5700K with Thrive



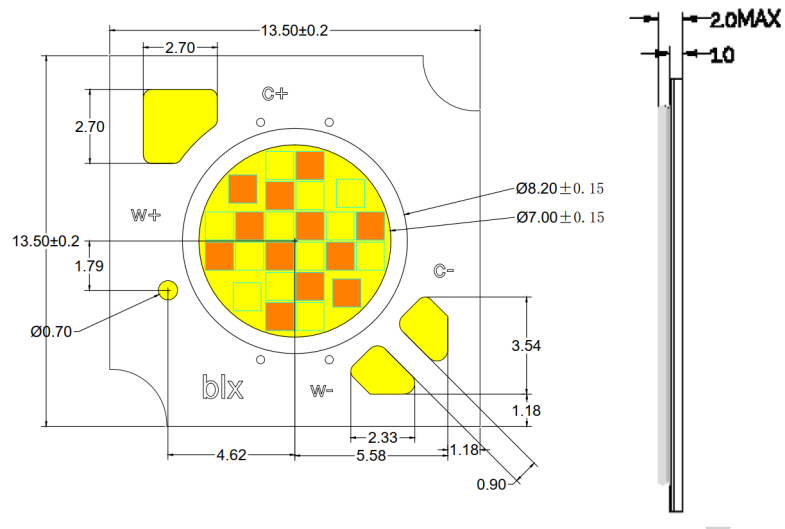
Note for Figure 35:

1. Color spectra measured at nominal current and  $T_c = 85^\circ\text{C}$ .

# Mechanical Dimensions

**Figure 36: Drawing for Vesta Series Tunable White HD TW 6mm, 36V**

BXRV-TR-xxxxX-06D0-A-3X

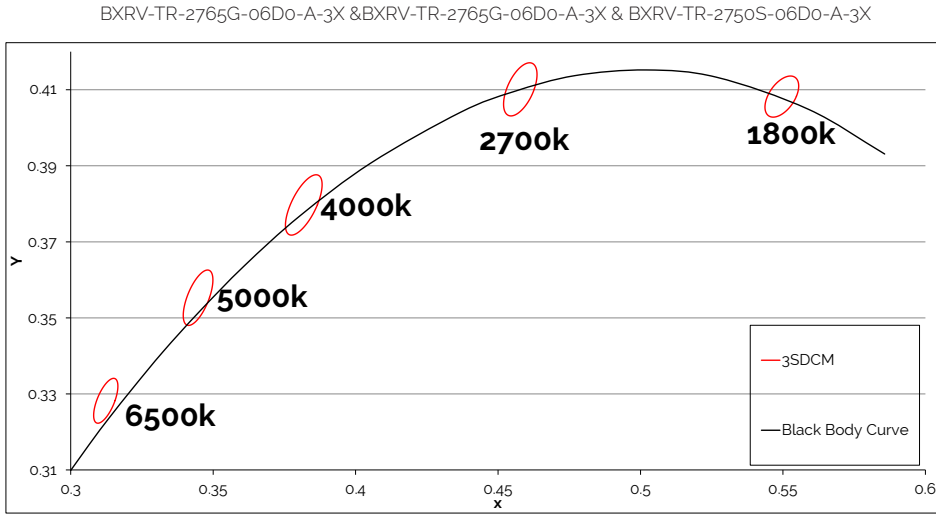


Notes for Figure 36:

1. Solder pads are labeled "+" to denote positive polarity and "-" to denote negative polarity. Solder pads have a gold surface finish.
2. Drawings are not to scale.
3. Drawing dimensions are in millimeters.
4. Unless otherwise specified, tolerances are  $\pm 0.20$ mm.
5. The optical center of the LED array is nominally defined by the mechanical center of the array.
6. Bridgelux maintains a flatness of 0.1 mm across the mounting surface of the array. Refer to Application Notes for product handling, mounting and heat sink recommendations.

# Color Binning Information

**Figure 37: Graph of Bins in xy Color Space, Tc=85°C**



**Table 8: McAdam ellipse CCT color bin definitions for product operating at  $T_c = 85^\circ\text{C}$**

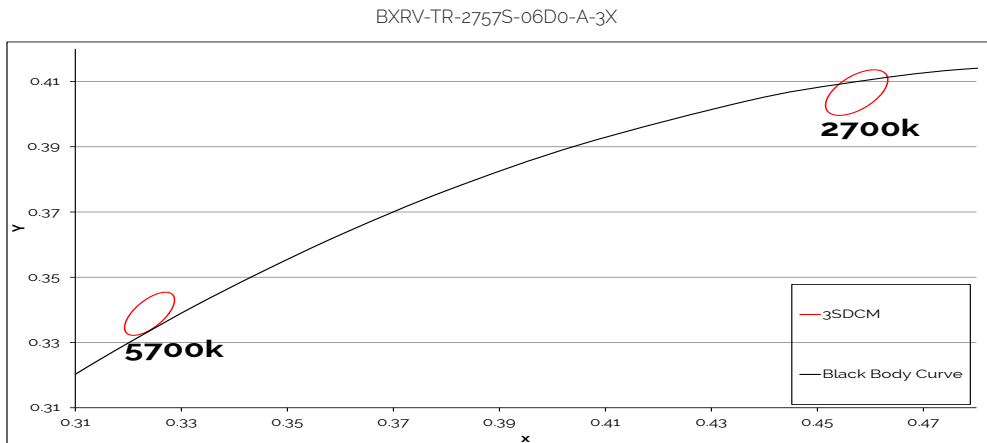
CCT	Center Point	Bin Size	Axis a	Axis b	Rotation Angle
1800K	x=0.5496 y= 0.4082	3 SDCM	0.00698	0.0039	40.00°
2700K	x=0.4578 y= 0.4101	3 SDCM	0.00810	0.00420	53.70°
4000K	x=0.3818 y= 0.3797	3 SDCM	0.0094	0.0040	53.72°
5000K	x=0.3447 y=0.3553	3 SDCM	0.00822	0.00354	59.62°
6500K	x=0.3123 y=0.3282	3 SDCM	0.00669	0.00285	58.57°

Notes for Table 8:

1. The x,y center points are the center points of the respective ANSI bins in the CIE 1931 xy Color Space
2. Products are binned at Tc=85°C
3. Bridgelux maintains a tolerance of +/-0.007 on x and y color coordinates in the CIE 1931 Color Space

# Color Binning Information

**Figure 38: Graph of Bins in xy Color Space, Tc=85°C**



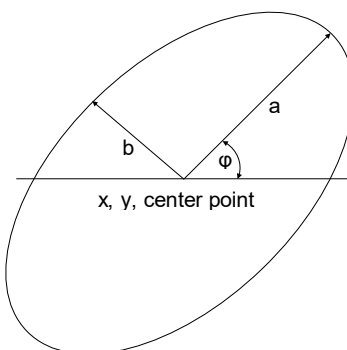
**Table 9: McAdam ellipse CCT color bin definitions for product operating at  $T_c = 85^\circ\text{C}$**

CCT	Center Point	Bin Size	Axis a	Axis b	Rotation Angle
2700K	x=0.4574 y= 0.4066	3 SDCM	0.00810	0.00420	53.70°
5700K	x=0.3240 y=0.3388	3 SDCM	0.00746	0.0032	59'05'

Notes for Table 9:

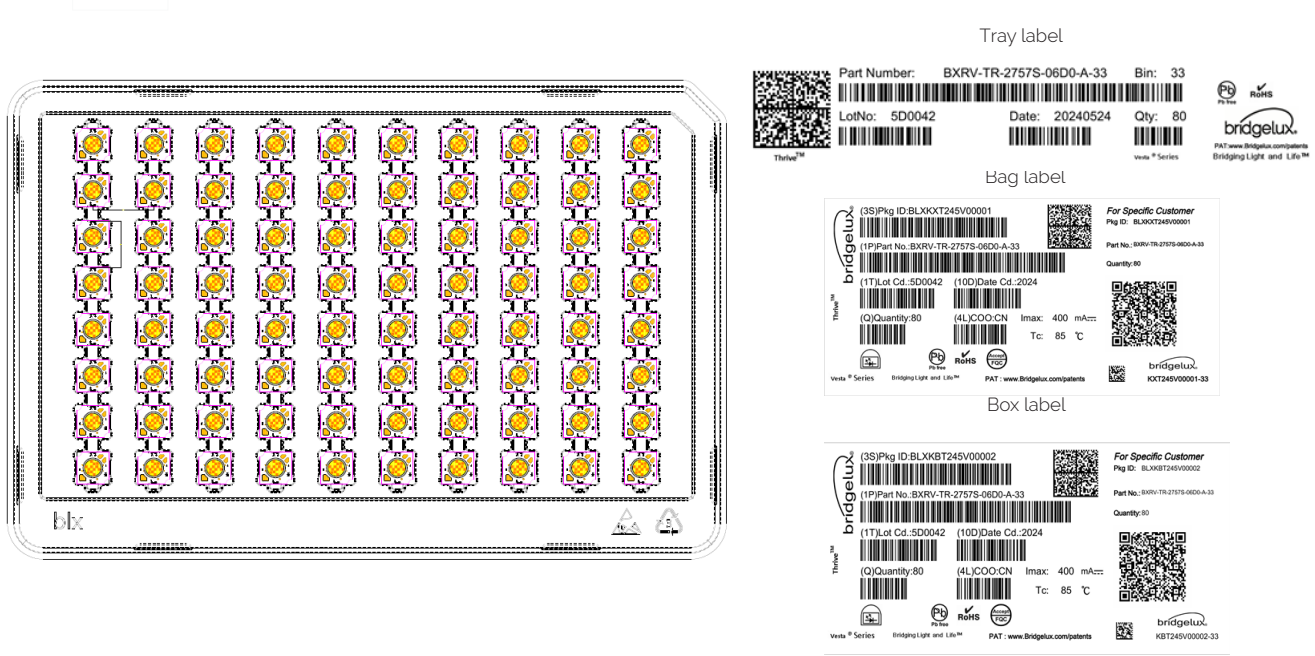
1. The x,y center points are the center points of the respective ANSI bins in the CIE 1931 xy Color Space
2. Products are binned at  $T_c=85^\circ\text{C}$
3. Bridgelux maintains a tolerance of +/-0.007 on x and y color coordinates in the CIE 1931 Color Space

**Figure 39: Definition of the McAdam ellipse**



# Packaging and Labeling

**Figure 40: Vesta Series Tunable White 6mm Packaging and Labeling**



Notes for Figure 40:

1. Each tray holds 80 Vesta Series Tunable White 6mm arrays.
2. Four plus one trays are sealed in an anti-static bag. Up to two such bags are placed in an inner box. Up to eight inner boxes are placed in a box and shipped. Depending on quantities ordered, a bigger shipping box, containing eight boxes will be used to ship products.
3. Each bag and box is to be labeled as shown above.
4. Dimensions for each tray are 300 mm (L) x 200 mm (W) x 0.8 mm (T). Dimensions for the anti-static bag are 400 mm (W) x 300 mm (L) x 0.14 mm (T) and that of the inner box are 350 mm (L) x 245 mm (W) x 67 mm (H).

**Figure 41: Product Labeling**

Bridgelux arrays have laser markings on the back side of the substrate to help with product identification. In addition to the product identification markings, Bridgelux arrays also contain markings for internal Bridgelux manufacturing use only. The image below shows which markings are for customer use and which ones are for Bridgelux internal use only. The Bridgelux internal manufacturing markings are subject to change without notice, however these will not impact the form, function or performance of the array.



# Design Resources

## Application Notes

Vesta Series Tunable White arrays are intended for use in dry, indoor applications. Bridgelux has developed a comprehensive set of application notes and design resources to assist customers in successfully designing with the Vesta Series product family of LED array products. For a list of resources under development, visit [www.bridgelux.com](http://www.bridgelux.com).

## Optical Source Models

Optical source models and ray set files are available for all Bridgelux products. For a list of available formats, visit [www.bridgelux.com](http://www.bridgelux.com).

## 3D CAD Models

Three dimensional CAD models depicting the product outline of all Bridgelux Vesta Series LED arrays are available in both IGS and STEP formats. Please contact your Bridgelux sales representative for assistance.

## LM80

Please contact your Bridgelux sales representative for more information.

# Precautions

## CAUTION: CHEMICAL EXPOSURE HAZARD

Exposure to some chemicals commonly used in luminaire manufacturing and assembly can cause damage to the LED array. Please consult Bridgelux Application Notes, ANg2, ANg3 and AN101 for additional information.

## CAUTION: RISK OF BURN

Do not touch the Vesta Series LED array during operation. Allow the array to cool for a sufficient period of time before handling. The Vesta Series LED array may reach elevated temperatures such that could burn skin when touched.

## CAUTION

### CONTACT WITH LIGHT EMITTING SURFACE (LES)

Avoid any contact with the LES. Do not touch the LES of the LED array or apply stress to the LES (yellow phosphor resin area). Contact may cause damage to the LED array.

Optics and reflectors must not be mounted in contact with the LES (yellow phosphor resin area). Optical devices may be mounted on the top surface of the Vesta Series LED array. Use the mechanical features of the LED array housing, edges and/or mounting holes to locate and secure optical devices as needed.

# Disclaimers

## STANDARD TEST CONDITIONS

Unless otherwise stated, array testing is performed at the nominal drive current.

## MINOR PRODUCT CHANGE POLICY

The rigorous qualification testing on products offered by Bridgelux provides performance assurance. Slight cosmetic changes that do not affect form, fit, or function may occur as Bridgelux continues product optimization.

# About Bridgelux: Bridging Light and Life™

At Bridgelux, we help companies, industries and people experience the power and possibility of light. Since 2002, we've designed LED solutions that are high performing, energy efficient, cost effective and easy to integrate. Our focus is on light's impact on human behavior, delivering products that create better environments, experiences and returns—both experiential and financial. And our patented technology drives new platforms for commercial and industrial luminaires.

**For more information about the company, please visit**

**[bridgelux.com](http://bridgelux.com)**

**[twitter.com/Bridgelux](https://twitter.com/Bridgelux)**

**[facebook.com/Bridgelux](https://facebook.com/Bridgelux)**

**[youtube.com/user/Bridgelux](https://youtube.com/user/Bridgelux)**

**[linkedin.com/company/bridgelux](https://linkedin.com/company/bridgelux)**

**WeChat ID: BridgeluxInChina**



46410 Fremont Blvd  
Fremont, CA 94538 USA  
Tel (925) 583-8400  
**[www.bridgelux.com](http://www.bridgelux.com)**

© 2025 Bridgelux, Inc. All rights reserved 2022. Product specifications are subject to change without notice. Bridgelux, the Bridgelux stylized logo design and Vesta are registered trademarks of Bridgelux, Inc. All other trademarks are the property of their respective owners.

**Bridgelux Vesta Series Tunable White HD TW 6mm Array Product Data Sheet DS1751 Rev. A (10/2025)**