

# Bridgelux® SMD 5050 5W 24V

Product Data Sheet DS911

# Introduction

SMD 5050

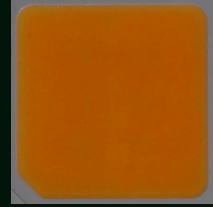

The Bridgelux SMD 5050 high power LED is hot-color targeted, which ensures that the LEDs fall within their specified color bin at the typical application conditions of 85°C. With its broad lumen coverage and wide range of CCT and CRI options, the SMD 5050 provides unparalleled design-in flexibility for indoor and outdoor lighting applications. The SMD 5050 is ideal as a drop-in replacement for emitters with an industry standard 5.0mm x 5.0mm footprint.

## Features

- Industry-standard 5050 footprint
- 2 color bin options enable tight color control
- Hot-color targeting ensures that color is within the bin at the typical application condition of 85°C
- 3- and 5-step MacAdam ellipse options
- RoHS compliant and lead free
- Multiple CCT and CRI configurations for a wide range of lighting applications

## Benefits

- Lower operating and manufacturing cost
- Ease of design and rapid go-to-market
- Uniform consistent white light
- Compliant with environmental standards
- Design flexibility

# Contents

Product Feature Map	2
Product Nomenclature	2
Product Test Conditions	2
Product Selection Guide	4
Performance at Commonly Used Drive Currents	5
Electrical Characteristics	8
Absolute Maximum Ratings	9
Product Bin Definitions	10
Performance Curves	12
Typical Radiation Pattern	15
Typical Color Spectrum	16
Mechanical Dimensions	17
Reliability	18
Reflow Characteristics	19
Packaging	20
Design Resources	22
Precautions	22
Disclaimers	22
About Bridgelux	23

# Product Feature Map

Bridgelux SMD LED products come in industry standard package sizes and follow ANSI binning standards. These LEDs are optimized for cost and performance, helping to ensure highly competitive system lumen per dollar performance while addressing the stringent efficacy and reliability standards required for modern lighting applications.

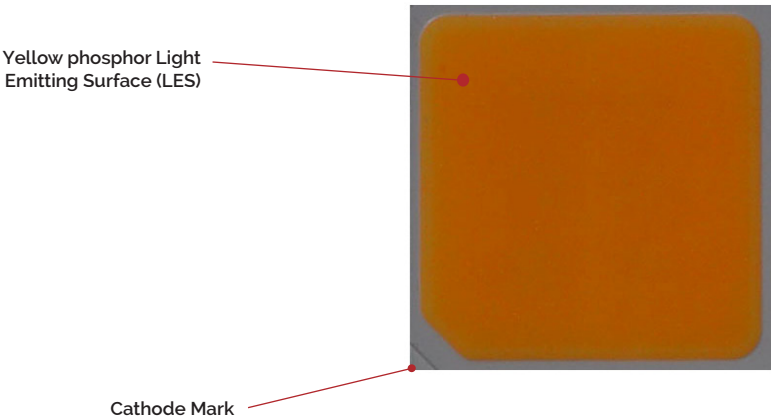

## Product Nomenclature

The part number designation for Bridgelux SMD 5050 is explained as follows:

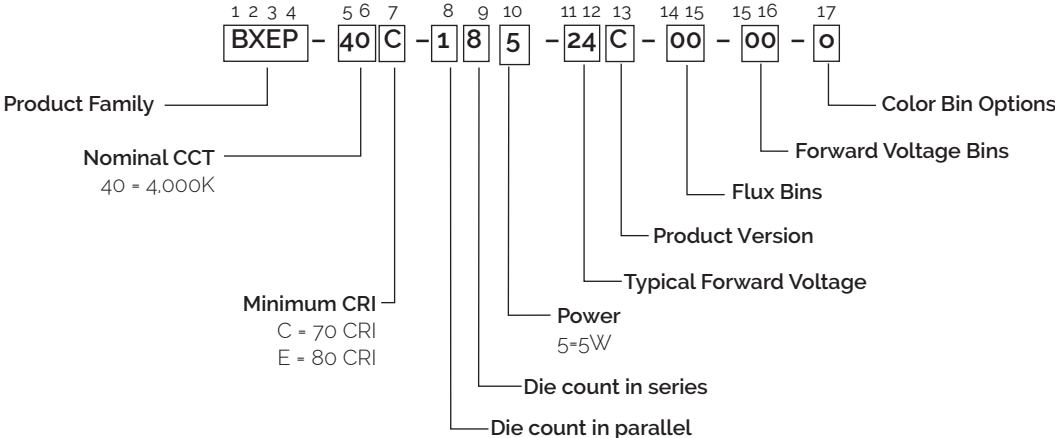

# Product Selection Guide

The following product configurations are available:

**Table 1:** Selection Guide, Pulsed Measurement Data at 160mA ( $T_j = T_{sp} = 25^\circ\text{C}$ )

Part Number <sup>6</sup>	Nominal CCT <sup>2</sup> (K)	CRI <sup>3-5</sup>	Nominal Drive Current (mA)	Forward Voltage <sup>4-5</sup> (V)			Typical Pulsed Flux (lm) <sup>4-5</sup>	Typical Power (W)	Typical Efficacy (lm/W)
				Min	Typical	Max			
BXEP-27C-185-24C-00-00-0	2700	70	160	23.0	24.4	26.0	647	3.9	166
BXEP-27E-185-24C-00-00-0	2700	80	160	23.0	24.4	26.0	597	3.9	153
BXEP-30C-185-24C-00-00-0	3000	70	160	23.0	24.4	26.0	666	3.9	171
BXEP-30E-185-24C-00-00-0	3000	80	160	23.0	24.4	26.0	615	3.9	158
BXEP-40C-185-24C-00-00-0	4000	70	160	23.0	24.4	26.0	709	3.9	182
BXEP-40E-185-24C-00-00-0	4000	80	160	23.0	24.4	26.0	654	3.9	168
BXEP-50C-185-24C-00-00-0	5000	70	160	23.0	24.4	26.0	709	3.9	182
BXEP-50E-185-24C-00-00-0	5000	80	160	23.0	24.4	26.0	654	3.9	168
BXEP-57C-185-24C-00-00-0	5700	70	160	23.0	24.4	26.0	702	3.9	180
BXEP-57E-185-24C-00-00-0	5700	80	160	23.0	24.4	26.0	648	3.9	166
BXEP-65C-185-24C-00-00-0	6500	70	160	23.0	24.4	26.0	702	3.9	180
BXEP-65E-185-24C-00-00-0	6500	80	160	23.0	24.4	26.0	648	3.9	166

Notes for Table 1 :

- The last 7 characters (including hyphens '-') refer to flux bins, forward voltage bins, and color bin options, respectively. "00-00-0" denotes the full distribution of flux, forward voltage, and 5 SDCM color.  
Example: BXEP-40C-185-24C-00-00-0 refers to the full distribution of flux, forward voltage, and color within a 4000K 5-step ANSI standard chromaticity region with a minimum of 70CRI, 1x8 die configuration, 5w power, 24.4V typical forward voltage.
- Product CCT is hot targeted at  $T_{sp} = 85^\circ\text{C}$ . Nominal CCT as defined by ANSI C78.377-2011.
- Listed CRIs are minimum values and include test tolerance.
- Products tested under pulsed condition (10ms pulse width) at nominal drive current where  $T_j = T_{sp} = 25^\circ\text{C}$ .
- Bridgelux maintains a  $\pm 7.5\%$  tolerance on luminous flux measurements,  $\pm 0.1\text{V}$  tolerance on forward voltage measurements, and  $\pm 2$  tolerance on CRI measurements for the SMD 5050.
- Refer to Table 6 and Table 7 for Bridgelux SMD 5050 Luminous Flux Binning and Forward Voltage Binning information.

# Product Selection Guide

The following product configurations are available:

**Table 2:** Selection Guide, Stabilized DC Performance ( $T_{sp} = 85^{\circ}\text{C}$ )<sup>6,7</sup>

Part Number	Nominal CCT <sup>1</sup> (K)	CRI <sup>2,3</sup>	Nominal Drive Current (mA)	Forward Voltage <sup>3</sup> (V)			Typical DC Flux (lm) <sup>3</sup>	Typical DC Power (W)	Typical DC Effi- cacy (lm/W)
				Min	Typical	Max			
BXEP-27C-185-24C-00-00-0	2700	70	160	22.6	24.0	25.5	592	3.8	154
BXEP-27E-185-24C-00-00-0	2700	80	160	22.6	24.0	25.5	546	3.8	142
BXEP-30C-185-24C-00-00-0	3000	70	160	22.6	24.0	25.5	609	3.8	159
BXEP-30E-185-24C-00-00-0	3000	80	160	22.6	24.0	25.5	562	3.8	147
BXEP-40C-185-24C-00-00-0	4000	70	160	22.6	24.0	25.5	648	3.8	169
BXEP-40E-185-24C-00-00-0	4000	80	160	22.6	24.0	25.5	598	3.8	156
BXEP-50C-185-24C-00-00-0	5000	70	160	22.6	24.0	25.5	648	3.8	169
BXEP-50E-185-24C-00-00-0	5000	80	160	22.6	24.0	25.5	598	3.8	156
BXEP-57C-185-24C-00-00-0	5700	70	160	22.6	24.0	25.5	642	3.8	167
BXEP-57E-185-24C-00-00-0	5700	80	160	22.6	24.0	25.5	592	3.8	155
BXEP-65C-185-24C-00-00-0	6500	70	160	22.6	24.0	25.5	642	3.8	167
BXEP-65E-185-24C-00-00-0	6500	80	160	22.6	24.0	25.5	592	3.8	155

Notes for Table 2:

- The last 7 characters (including hyphens '-') refer to flux bins, forward voltage bins, and color bin options, respectively. "00-00-0" denotes the full distribution of flux, forward voltage, and 5 SDCM color.  
EExample: BXEP-40C-185-24C-00-00-0 refers to the full distribution of flux, forward voltage, and color within a 4000K 5-step ANSI standard chromaticity region with a minimum of 70CRI, 1x8 die configuration, 5w power, 24.4V typical forward voltage.
- Product CCT is hot targeted at  $T_{sp} = 85^{\circ}\text{C}$ . Nominal CCT as defined by ANSI C78.377-2011.
- Listed CRIs are minimum values and include test tolerance.
- Bridgelux maintains a  $\pm 7.5\%$  tolerance on luminous flux measurements,  $\pm 0.1\text{V}$  tolerance on forward voltage measurements, and  $\pm 2$  tolerance on CRI measurements for the SMD 5050.
- Refer to Table 6 and Table 7 for Bridgelux SMD 5050 Luminous Flux Binning and Forward Voltage Binning information.
- Typical stabilized DC performance values are provided as reference only and are not a guarantee of performance.
- Typical performance is estimated based on operation under DC (direct current) with LED emitter mounted onto a heat sink with thermal interface material and the solder point temperature maintained at  $85^{\circ}\text{C}$ . Based on Bridgelux test setup, values may vary depending on the thermal design of the luminaire and/or the exposed environment to which the product is subjected.

# Performance at Commonly Used Drive Currents

SMD 5050 LEDs are tested to the specifications shown using the nominal drive currents in Table 1. SMD 5050 may also be driven at other drive currents dependent on specific application design requirements. The performance at any drive current can be derived from the current vs. voltage characteristics shown in Figure 2 and the relative luminous flux vs. current characteristics shown in Figure 3. The performance at commonly used drive currents is summarized in Table 3.

**Table 3:** Performance at Commonly Used Drive Currents

Part Number	CRI	Drive Current <sup>1</sup> (mA)	Typical $V_f$ $T_{sp} = 25^\circ\text{C}$ (V)	Typical Power $T_{sp} = 25^\circ\text{C}$ (W)	Typical Pulsed Flux <sup>2</sup> $T_{sp} = 25^\circ\text{C}$ (lm)	Typical DC Flux <sup>3</sup> $T_{sp} = 85^\circ\text{C}$ (lm)	Typical Efficacy $T_{sp} = 25^\circ\text{C}$ (lm/W)
BXEP-27C-185-24C-00-00-0	70	45	21.9	1.0	194	181	197
		90	22.9	2.1	379	351	183
		135	23.9	3.2	554	508	172
		<b>160</b>	<b>24.4</b>	<b>3.9</b>	<b>647</b>	<b>592</b>	<b>166</b>
		180	24.8	4.5	720	656	161
		200	25.2	5.0	792	718	157
		250	26.1	6.5	962	867	147
BXEP-27E-185-24C-00-00-0	80	45	21.9	1.0	179	167	182
		90	22.9	2.1	349	324	169
		135	23.9	3.2	511	469	158
		<b>160</b>	<b>24.4</b>	<b>3.9</b>	<b>597</b>	<b>546</b>	<b>153</b>
		180	24.8	4.5	665	605	149
		200	25.2	5.0	730	663	145
		250	26.1	6.5	888	800	136
BXEP-30C-185-24C-00-00-0	70	45	21.9	1.0	200	186	202
		90	22.9	2.1	390	361	189
		135	23.9	3.2	570	523	177
		<b>160</b>	<b>24.4</b>	<b>3.9</b>	<b>666</b>	<b>609</b>	<b>171</b>
		180	24.8	4.5	741	675	166
		200	25.2	5.0	815	739	162
		250	26.1	6.5	990	892	152
BXEP-30E-185-24C-00-00-0	80	45	21.9	1.0	184	172	187
		90	22.9	2.1	360	334	174
		135	23.9	3.2	526	483	163
		<b>160</b>	<b>24.4</b>	<b>3.9</b>	<b>615</b>	<b>562</b>	<b>158</b>
		180	24.8	4.5	685	624	153
		200	25.2	5.0	752	683	149
		250	26.1	6.5	915	824	140

Notes for Table 3:

1. Alternate drive currents in Table 3 are provided for reference only and are not a guarantee of performance.
2. Bridgelux maintains a  $\pm 7.5\%$  tolerance on flux measurements.
3. Typical stabilized DC performance values are provided as reference only and are not a guarantee of performance.

# Performance at Commonly Used Drive Currents

SMD 5050 LEDs are tested to the specifications shown using the nominal drive currents in Table 1. SMD 5050 may also be driven at other drive currents dependent on specific application design requirements. The performance at any drive current can be derived from the current vs. voltage characteristics shown in Figure 2 and the relative luminous flux vs. current characteristics shown in Figure 3. The performance at commonly used drive currents is summarized in Table 3.

**Table 3:** Performance at Commonly Used Drive Currents

Part Number	CRI	Drive Current <sup>1</sup> (mA)	Typical $V_f$ $T_{sp} = 25^\circ\text{C}$ (V)	Typical Power $T_{sp} = 25^\circ\text{C}$ (W)	Typical Pulsed Flux <sup>2</sup> $T_{sp} = 25^\circ\text{C}$ (lm)	Typical DC Flux <sup>3</sup> $T_{sp} = 85^\circ\text{C}$ (lm)	Typical Efficacy $T_{sp} = 25^\circ\text{C}$ (lm/W)
BXEP-40C-185-24C-00-00-0	70	45	21.9	1.0	213	199	216
		90	22.9	2.1	415	385	201
		135	23.9	3.2	607	557	188
		<b>160</b>	<b>24.4</b>	<b>3.9</b>	<b>709</b>	<b>648</b>	<b>182</b>
		180	24.8	4.5	789	719	177
		200	25.2	5.0	867	787	172
		250	26.1	6.5	1054	950	161
BXEP-40E-185-24C-00-00-0	80	45	21.9	1.0	196	183	199
		90	22.9	2.1	383	355	185
		135	23.9	3.2	560	513	174
		<b>160</b>	<b>24.4</b>	<b>3.9</b>	<b>654</b>	<b>598</b>	<b>168</b>
		180	24.8	4.5	728	663	163
		200	25.2	5.0	800	726	159
		250	26.1	6.5	973	876	149
BXEP-50C-185-24C-00-00-0	70	45	21.9	1.0	213	199	216
		90	22.9	2.1	415	385	201
		135	23.9	3.2	607	557	188
		<b>160</b>	<b>24.4</b>	<b>3.9</b>	<b>709</b>	<b>648</b>	<b>182</b>
		180	24.8	4.5	789	719	177
		200	25.2	5.0	867	787	172
		250	26.1	6.5	1054	950	161
BXEP-50E-185-24C-00-00-0	80	45	21.9	1.0	196	183	199
		90	22.9	2.1	383	355	185
		135	23.9	3.2	560	513	174
		<b>160</b>	<b>24.4</b>	<b>3.9</b>	<b>654</b>	<b>598</b>	<b>168</b>
		180	24.8	4.5	728	663	163
		200	25.2	5.0	800	726	159
		250	26.1	6.5	973	876	149

Notes for Table 3:

1. Alternate drive currents in Table 3 are provided for reference only and are not a guarantee of performance.
2. Bridgelux maintains a  $\pm 7.5\%$  tolerance on flux measurements.
3. Typical stabilized DC performance values are provided as reference only and are not a guarantee of performance.



# Performance at Commonly Used Drive Currents

SMD 5050 LEDs are tested to the specifications shown using the nominal drive currents in Table 1. SMD 5050 may also be driven at other drive currents dependent on specific application design requirements. The performance at any drive current can be derived from the current vs. voltage characteristics shown in Figure 2 and the relative luminous flux vs. current characteristics shown in Figure 3. The performance at commonly used drive currents is summarized in Table 3.

**Table 3:** Performance at Commonly Used Drive Currents

Part Number	CRI	Drive Current <sup>1</sup> (mA)	Typical $V_f$ $T_{sp} = 25^\circ\text{C}$ (V)	Typical Power $T_{sp} = 25^\circ\text{C}$ (W)	Typical Pulsed Flux <sup>2</sup> $T_{sp} = 25^\circ\text{C}$ (lm)	Typical DC Flux <sup>3</sup> $T_{sp} = 85^\circ\text{C}$ (lm)	Typical Efficacy $T_{sp} = 25^\circ\text{C}$ (lm/W)
BXEP-57C-185-24C-00-00-0	70	45	21.9	1.0	210	197	213
		90	22.9	2.1	411	381	199
		135	23.9	3.2	601	551	186
		<b>160</b>	<b>24.4</b>	<b>3.9</b>	<b>702</b>	<b>642</b>	<b>180</b>
		180	24.8	4.5	781	712	175
		200	25.2	5.0	859	779	170
		250	26.1	6.5	1044	941	160
BXEP-57E-185-24C-00-00-0	80	45	21.9	1.0	194	181	197
		90	22.9	2.1	379	352	184
		135	23.9	3.2	555	509	172
		<b>160</b>	<b>24.4</b>	<b>3.9</b>	<b>648</b>	<b>592</b>	<b>166</b>
		180	24.8	4.5	721	657	162
		200	25.2	5.0	793	719	157
		250	26.1	6.5	964	868	148
BXEP-65C-185-24C-00-00-0	70	45	21.9	1.0	210	197	213
		90	22.9	2.1	411	381	199
		135	23.9	3.2	601	551	186
		<b>160</b>	<b>24.4</b>	<b>3.9</b>	<b>702</b>	<b>642</b>	<b>180</b>
		180	24.8	4.5	781	712	175
		200	25.2	5.0	859	779	170
		250	26.1	6.5	1044	941	160
BXEP-65E-185-24C-00-00-0	80	45	21.9	1.0	194	181	197
		90	22.9	2.1	379	352	184
		135	23.9	3.2	555	509	172
		<b>160</b>	<b>24.4</b>	<b>3.9</b>	<b>648</b>	<b>592</b>	<b>166</b>
		180	24.8	4.5	721	657	162
		200	25.2	5.0	793	719	157
		250	26.1	6.5	964	868	148

Notes for Table 3:

1. Alternate drive currents in Table 3 are provided for reference only and are not a guarantee of performance.
2. Bridgelux maintains a  $\pm 7.5\%$  tolerance on flux measurements.
3. Typical stabilized DC performance values are provided as reference only and are not a guarantee of performance.

# Electrical Characteristics

**Table 4:** Electrical Characteristics

Part Number	Drive Current (mA)	Forward Voltage (V) <sup>1,2</sup>			Typical Temperature Coefficient of Forward Voltage $\Delta V_f / \Delta T$ (mV/°C)	Typical Thermal Resistance Junction to Solder Point <sup>4</sup> $R_{j-sp}$ (°C/W)
		Minimum	Typical	Maximum		
BXEP-XXX-185-24C-00-00-0	160	23.0	24.4	26.0	-0.91	3.2

Notes for Table 4:

1. Bridgelux maintains a tolerance of  $\pm 0.1V$  on forward voltage measurements. Voltage minimum and maximum values at the nominal drive current are guaranteed by 100% test.
2. Products tested under pulsed condition (10ms pulse width) at nominal drive current where  $T_{sp} = 25^{\circ}C$ .
3. Thermal Resistance values based on 3000K 70CRI product.
4. Thermal resistance value was calculated using total electrical input power; optical power was not subtracted from input power.

# Absolute Maximum Ratings

**Table 5:** Maximum Ratings

Parameter	Maximum Rating
LED Junction Temperature ( $T_j$ )	125°C
Storage Temperature	-40°C to +105°C
Operating Solder Point Temperature ( $T_{sp}$ )	-40°C to +105°C
Soldering Temperature	260°C or lower for a maximum of 10 seconds
Maximum Drive Current <sup>1</sup>	250 mA
Maximum Peak Pulsed Forward Current <sup>2</sup>	300 mA
Maximum Reverse Voltage <sup>3</sup>	-
Moisture Sensitivity Rating	MSL 3
Electrostatic Discharge	2kV HBM. JEDEC-JS-001-HBM and JEDEC-JS-001-2012

Notes for Table 5:

1. Maximum drive current may be limited by the solder point temperature. Please see Figure 7 for further details.
2. Bridgelux recommends a maximum duty cycle of 10% and pulse width of 10 ms when operating LED SMD at maximum peak pulsed current specified. Maximum peak pulsed current indicate values where LED SMD can be driven without catastrophic failures.
3. Light emitting diodes are not designed to be driven in reverse voltage and will not produce light under this condition, no rating is provided.

# Product Bin Definitions

Table 6 lists the standard photometric luminous flux bins for Bridgelux SMD 5050 LEDs. Although several bins are listed, product availability in a particular bin varies by production run and by product performance. Not all bins are available in all CCTs.

**Table 6:** Luminous Flux Bin Definitions at 160mA,  $T_{sp}=25^{\circ}\text{C}$

Bin Code	Minimum	Maximum	Unit	Condition
A9	545	590	lm	$I_F=160\text{mA}$
B1	590	635		
B2	635	685		
B3	685	740		
B4	740	800		

Note for Table 6:

1. Bridgelux maintains a tolerance of  $\pm 7.5\%$  on luminous flux measurements.

**Table 7:** Forward Voltage Bin Definition at 160mA,  $T_{sp}=25^{\circ}\text{C}$

Bin Code	Minimum	Maximum	Unit	Condition
HE	23	24	V	$I_F=160\text{mA}$
HF	24	25		
HG	25	26		

Note for Table 7:

1. Bridgelux maintains a tolerance of  $\pm 0.1\text{V}$  on forward voltage measurements.

# Product Bin Definitions

**Table 8:** 3- and 5-step MacAdam Ellipse Color Bin Definitions

CCT	Color Space	Center Point		Major Axis	Minor Axis	Ellipse Rotation Angle	Color Bin
		X	Y				
2700K	3 SDCM	0.4578	0.4101	0.00810	0.00420	53.70	3
	5 SDCM	0.4578	0.4101	0.01350	0.00700	53.70	5
3000K	3 SDCM	0.4338	0.4030	0.00834	0.00408	53.22	3
	5 SDCM	0.4338	0.4030	0.01390	0.00680	53.22	5
4000K	3 SDCM	0.3818	0.3797	0.00939	0.00402	53.72	3
	5 SDCM	0.3818	0.3797	0.01565	0.00670	53.72	5
5000K	3 SDCM	0.3447	0.3553	0.00822	0.00354	59.62	3
	5 SDCM	0.3447	0.3553	0.01370	0.00590	59.62	5
5700K	3 SDCM	0.3287	0.3417	0.00746	0.00320	59.09	3
	5 SDCM	0.3287	0.3417	0.01243	0.00533	59.09	5
6500K	3 SDCM	0.3123	0.3282	0.00669	0.00285	58.57	3
	5 SDCM	0.3123	0.3282	0.01115	0.00475	58.57	5

Notes for Table 8:

1. Color binning at  $T_{sp} = 85^{\circ}\text{C}$
2. Bridgelux maintains a tolerance of  $\pm 0.007$  on x and y color coordinates in the CIE 1931 color space.

**Figure 1: C.I.E. 1931 Chromaticity Diagram (2 Color Bin Structure, Hot-color Targeted at  $T_{sp} = 85^{\circ}\text{C}$ )**

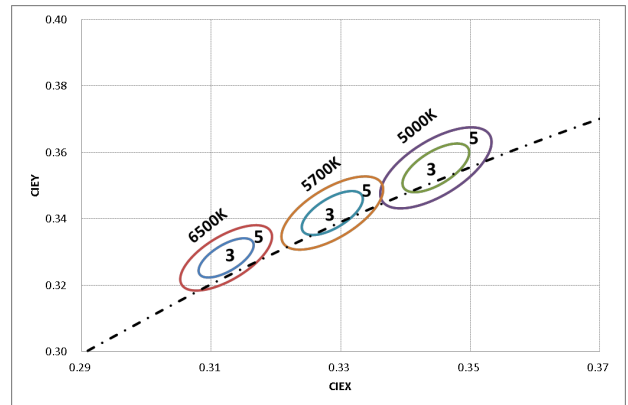
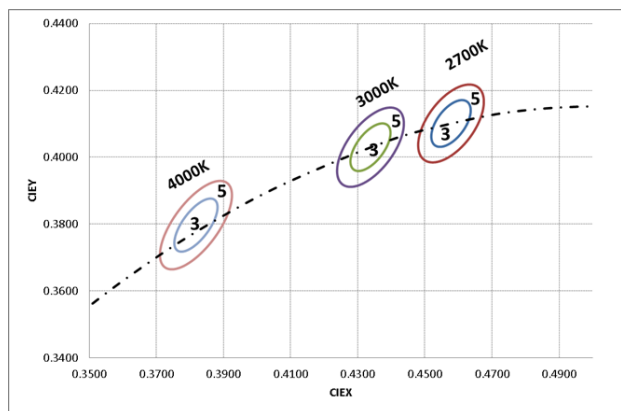

# Performance Curves

**Figure 2: Drive Current vs. Voltage ( $T_{sp}=25^{\circ}\text{C}$ )**

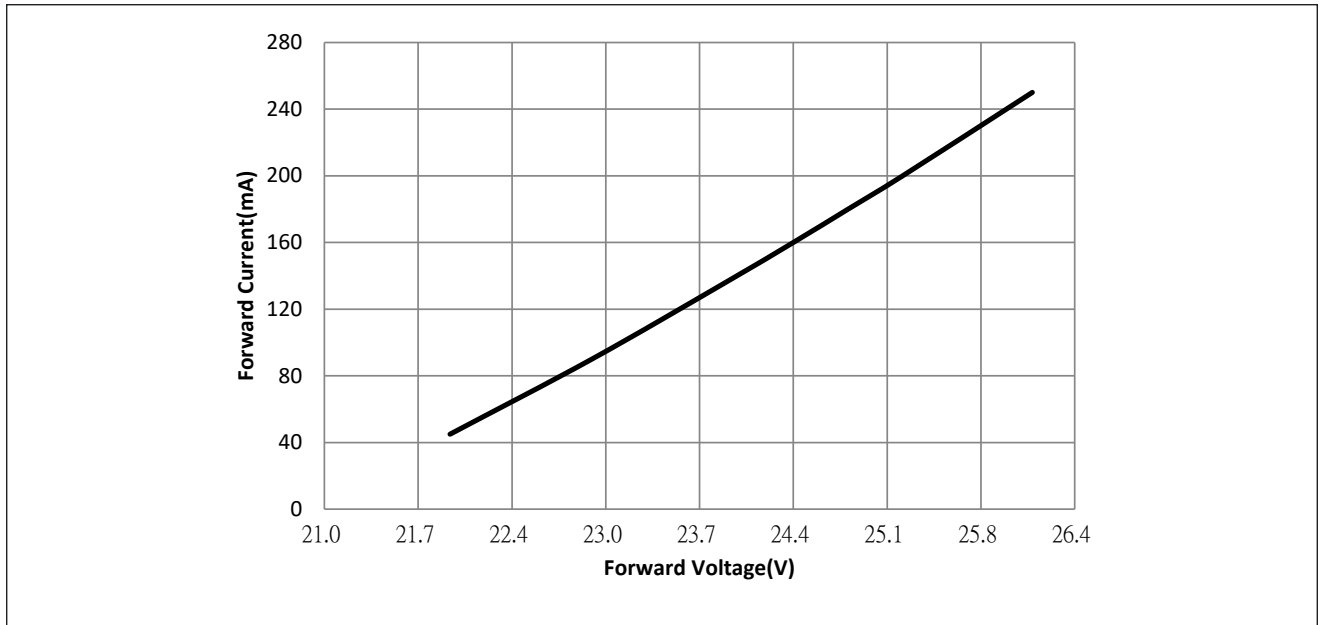

**Figure 3: Typical Relative Luminous Flux vs. Drive Current ( $T_{sp}=25^{\circ}\text{C}$ )**

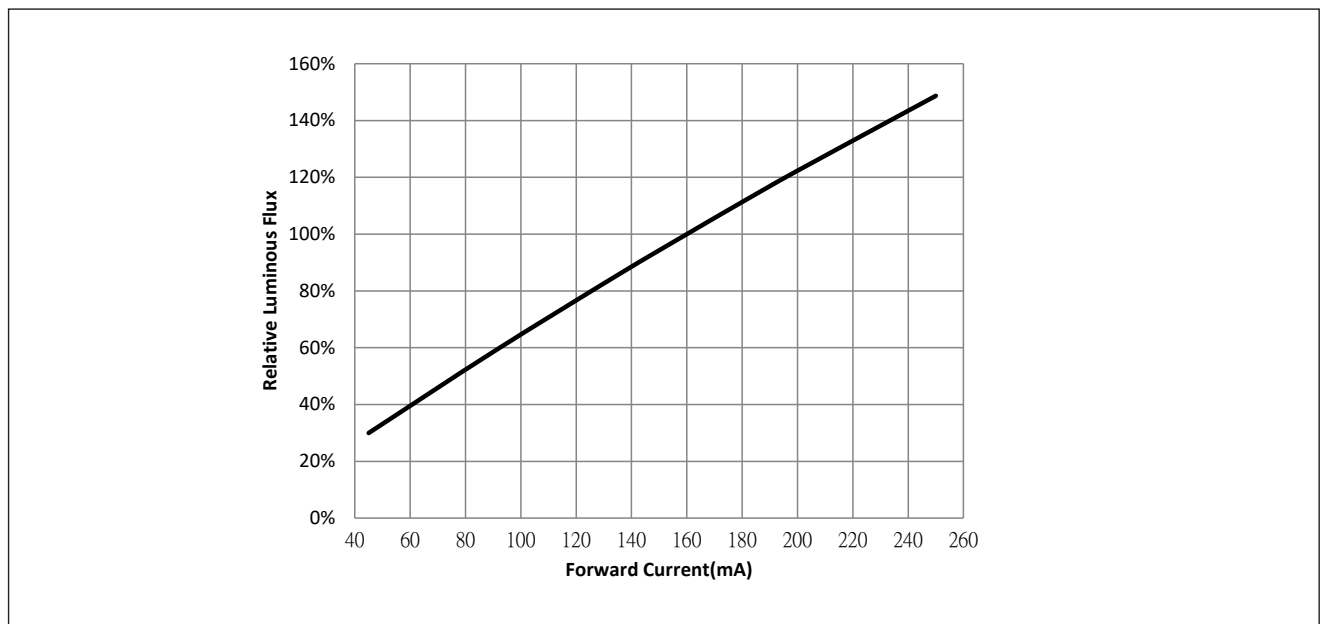

Note for Figure 3:

1. Bridgelux does not recommend driving high power LEDs at low currents. Doing so may produce unpredictable results. Pulse width modulation (PWM) is recommended for dimming effects.

# Performance Curves

**Figure 4: Typical Relative DC Flux vs. Solder Point Temperature**

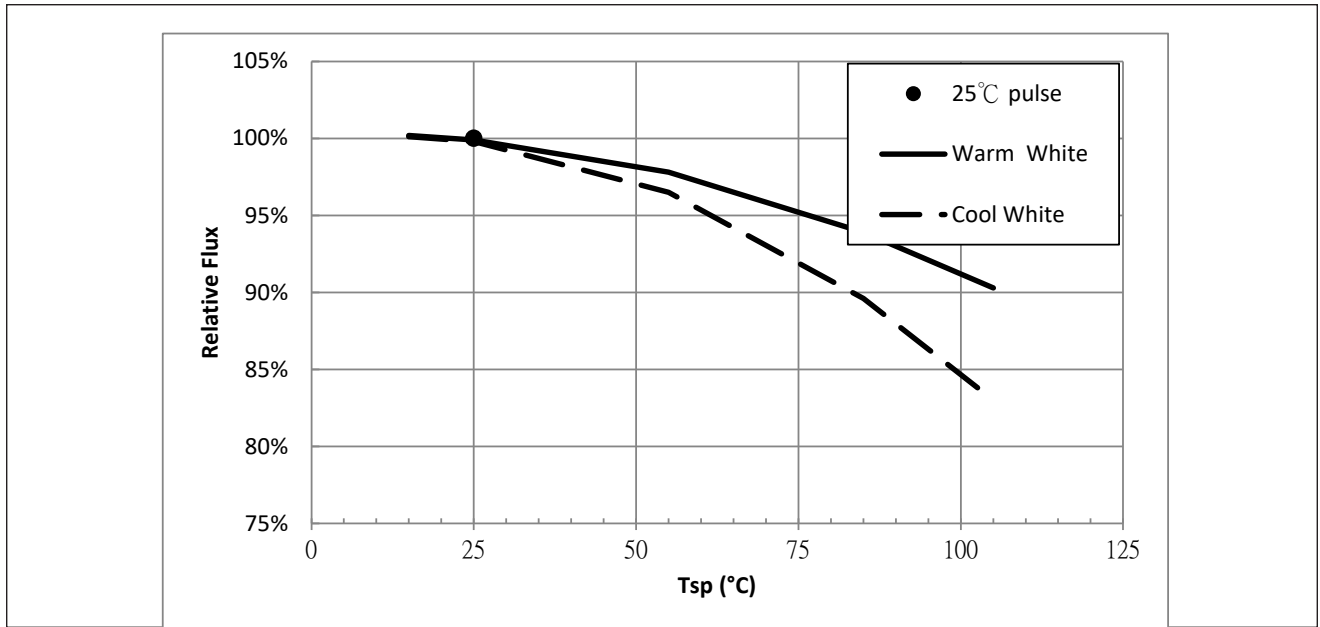

**Figure 5: Typical DC ccx Shift vs. Solder Point Temperature**

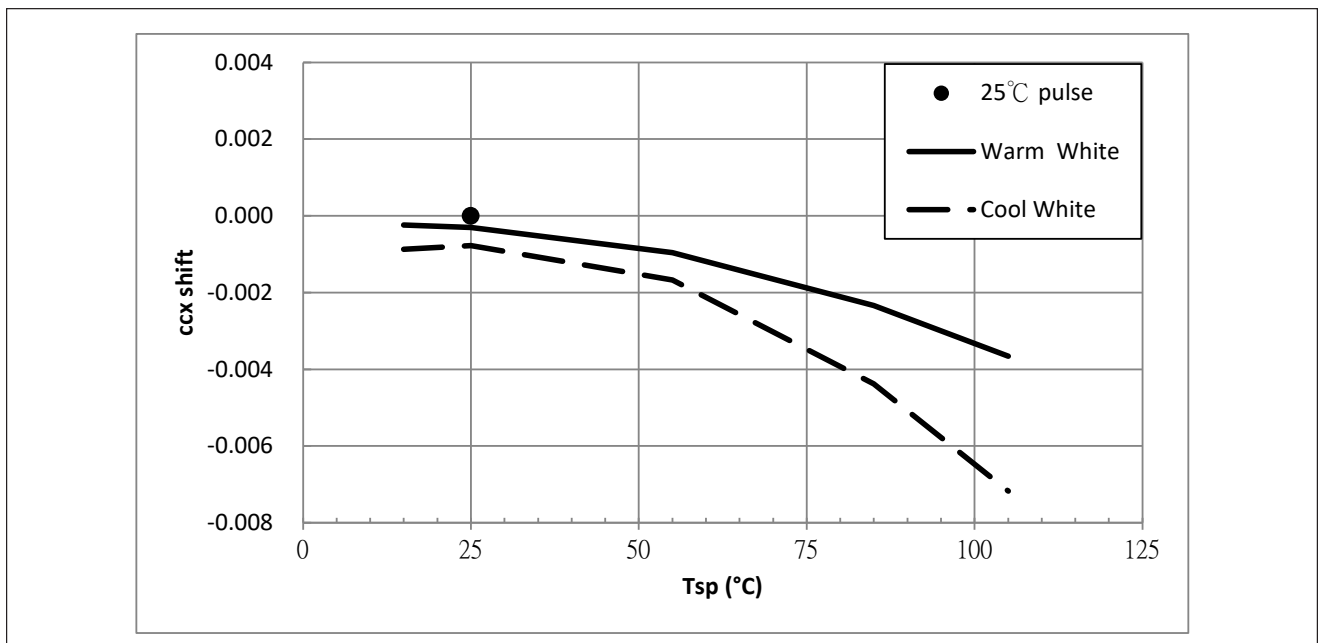

Notes for Figures 4 & 5:

1. Characteristics shown for warm white based on 3000K.
2. Characteristics shown for cool white based on 5700K.
3. For other color SKUs, the shift in color will vary. Please contact your Bridgelux Sales Representative for more information.

# Performance Curves

Figure 6: Typical DC ccy Shift vs. Solder Point Temperature

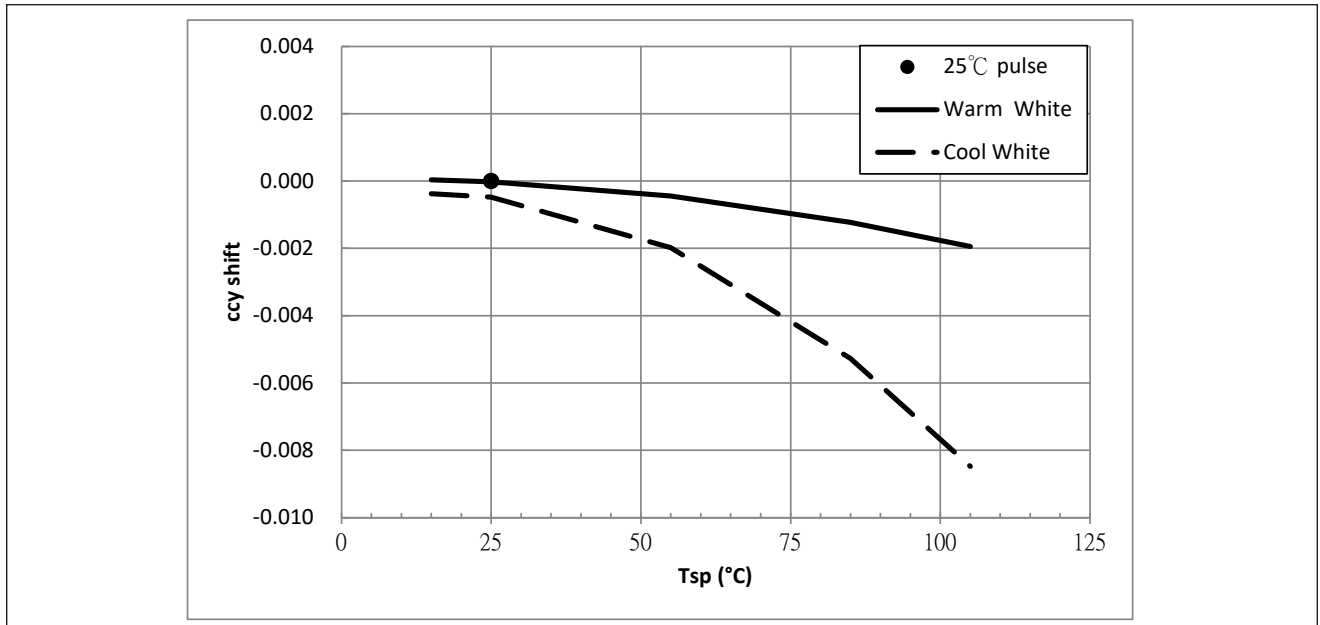

Notes for Figure 6:

1. Characteristics shown for warm white based on 3000K.
2. Characteristics shown for cool white based on 5700K.
3. For other color SKUs, the shift in color will vary. Please contact your Bridgelux Sales Representative for more information.

Figure 7: Drive Current Derating Curve

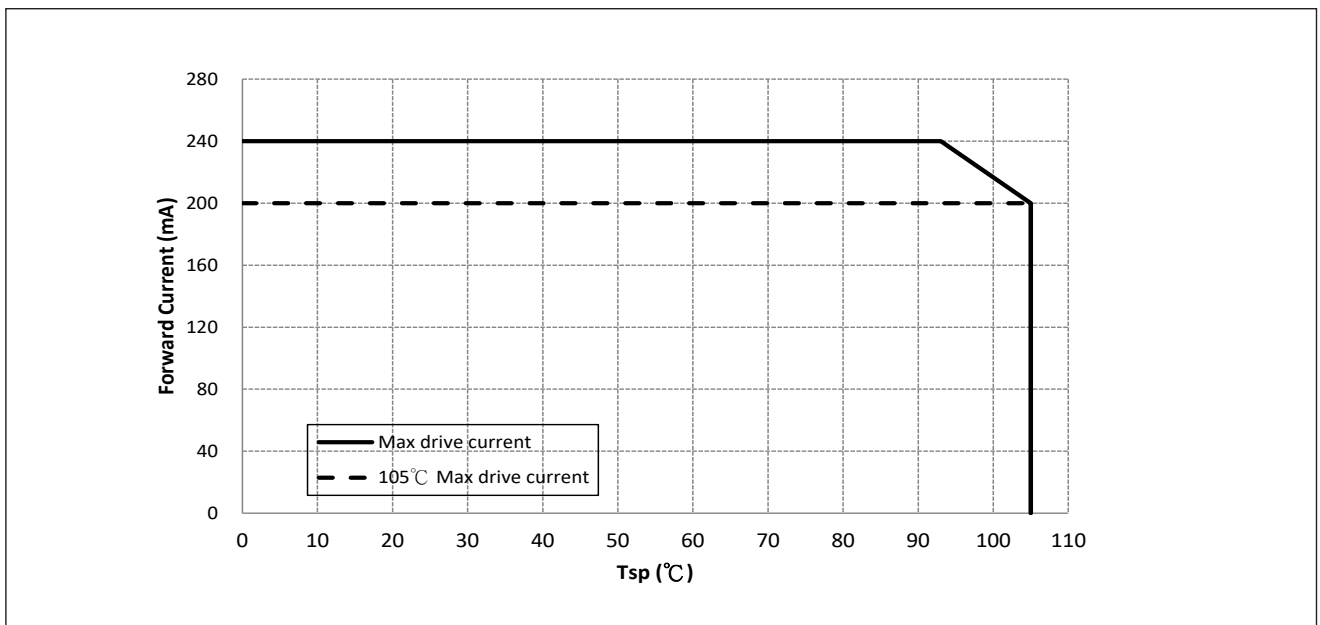



# Typical Radiation Pattern

Figure 8: Typical Spatial Radiation Pattern at 160mA,  $T_{sp} = 25^{\circ}\text{C}$

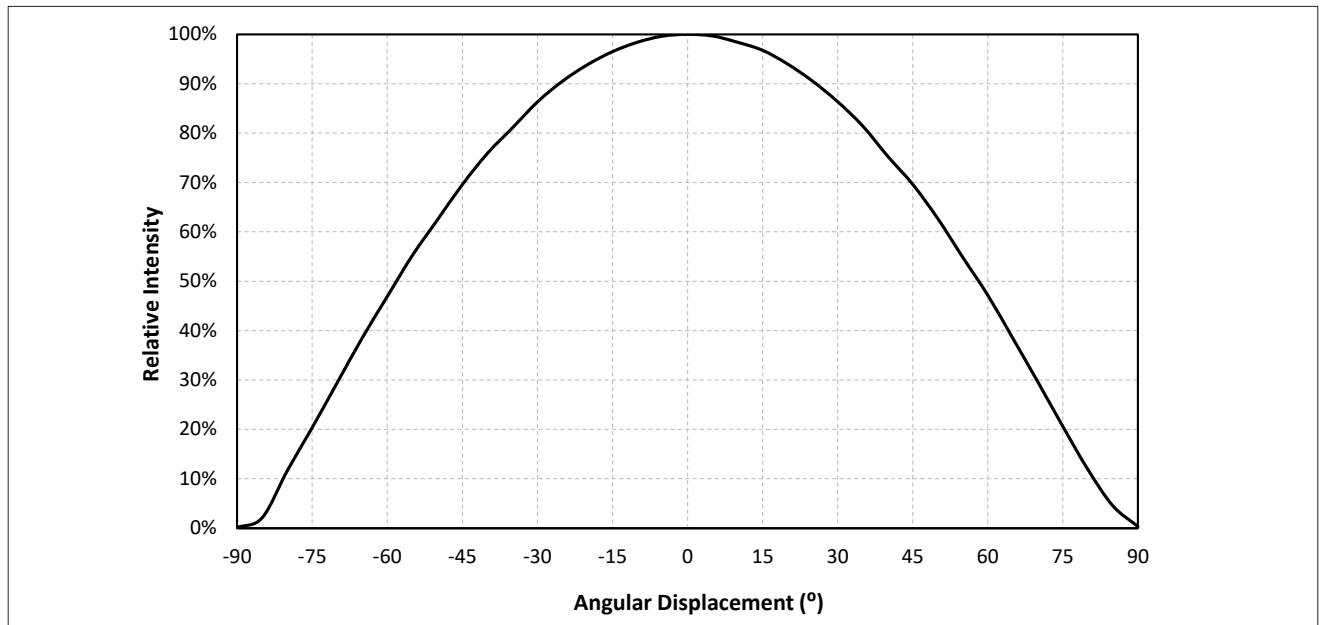

Notes for Figure 8:

1. Typical viewing angle is  $116^{\circ}$ .
2. The viewing angle is defined as the off axis angle from the centerline where luminous intensity (lv) is  $\frac{1}{2}$  of the peak value.

Figure 9: Typical Polar Radiation Pattern at 160mA,  $T_{sp} = 25^{\circ}\text{C}$

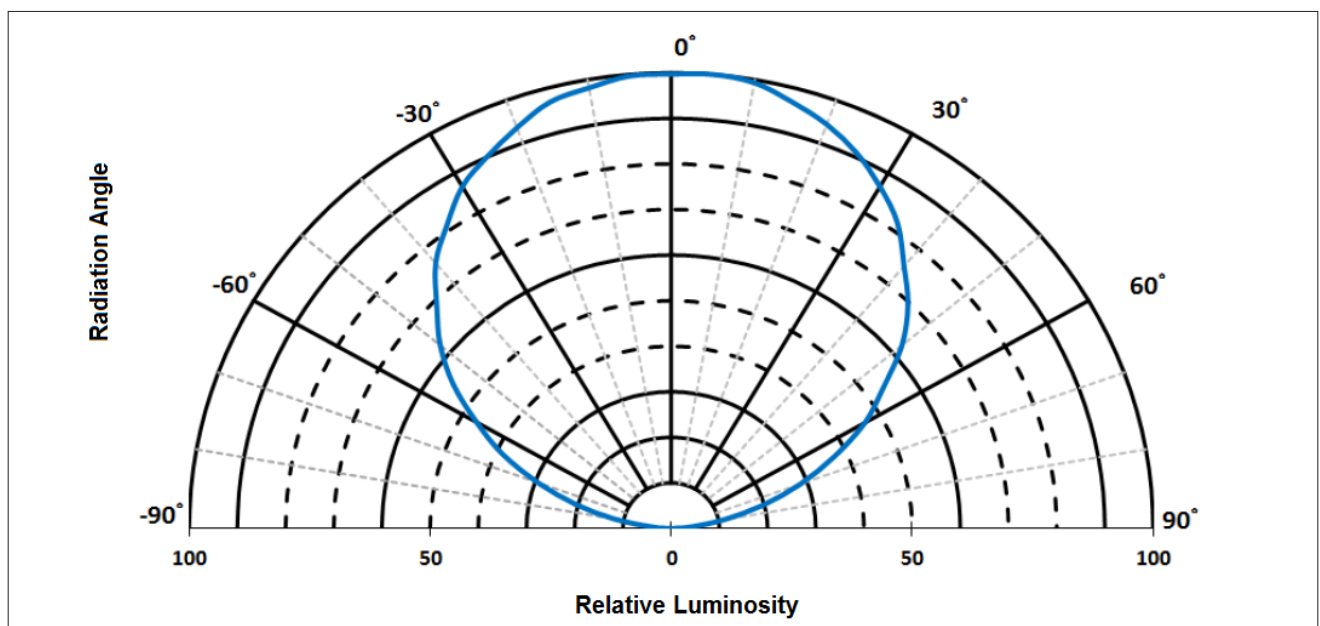

# Typical Color Spectrum

Figure 10: Typical Color Spectrum

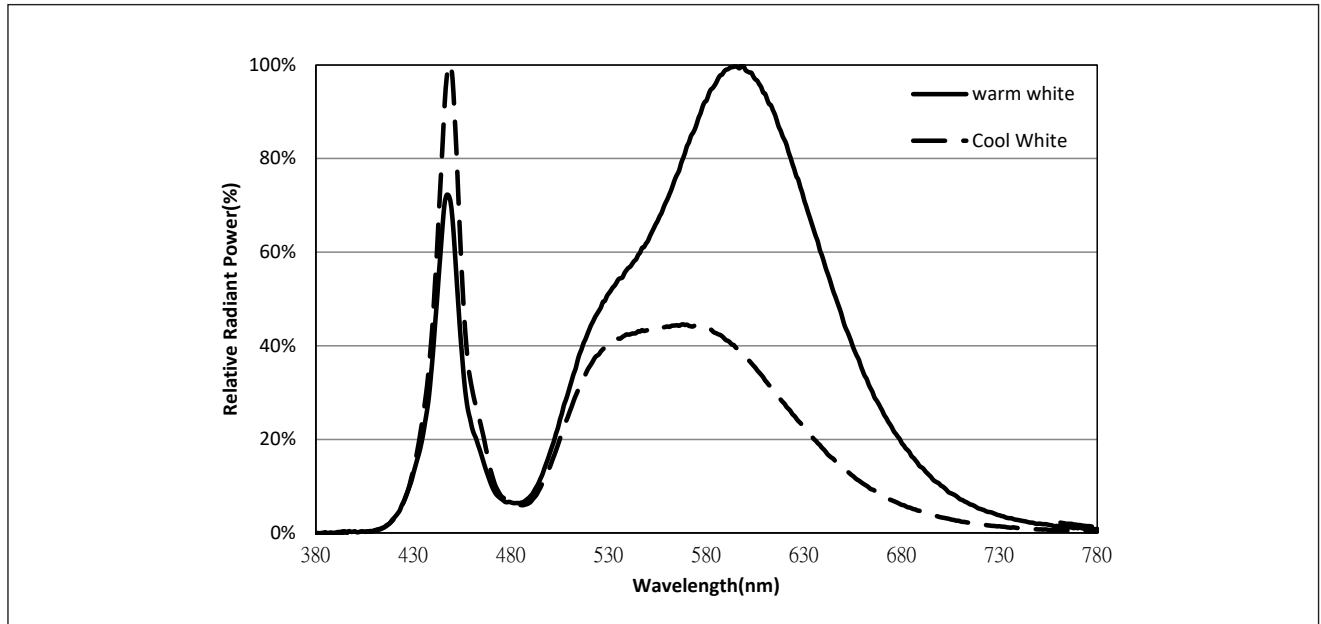

Notes for Figure 10:

1. Color spectra measured at nominal current for  $T_{sp} = 25^{\circ}\text{C}$
2. Color spectra shown for warm white is 3000K
3. Color spectra shown for cool white is 5700K

# Mechanical Dimensions

Figure 11: Drawing for SMD 5050

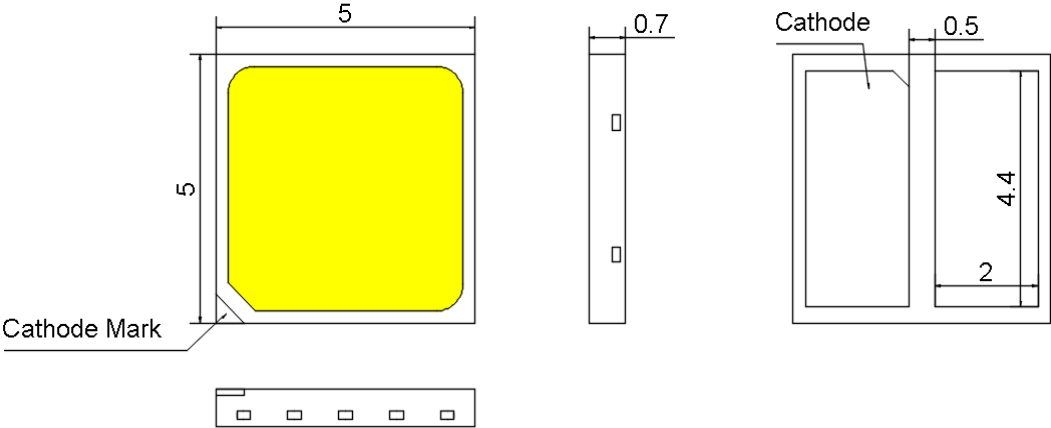

- Notes for Figure 11:
- 1. Drawings are not to scale.
  - 2. Drawing dimensions are in millimeters.
  - 3. Unless otherwise specified, tolerances are  $\pm 0.10\text{mm}$ .

### Recommended PCB Soldering Pad Pattern

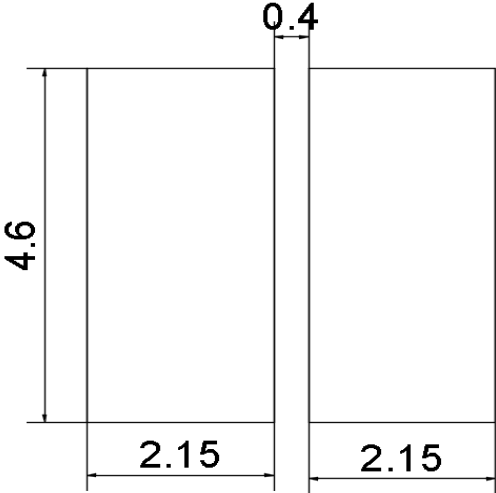

# Reliability

**Table 9:** Reliability Test Items and Conditions

No .	Items	Reference Standard	Test Conditions	Drive Current	Test Duration	Units Failed/ Tested
1	Moisture/Reflow Sensitivity	J-STD-020E	$T_{\text{slid}} = 260^{\circ}\text{C}$ , 10sec, Precondition: $60^{\circ}\text{C}$ , 60%RH, 168hr	-	3 reflows	0/22
2	Low Temperature Storage	JESD22-A119	$T_{\text{a}} = -40^{\circ}\text{C}$	-	1000 hours	0/22
3	High Temperature Storage	JESD22-A103D	$T_{\text{a}} = 105^{\circ}\text{C}$	-	1000 hours	0/22
4	Low Temperature Operating Life	JESD22-A108D	$T_{\text{a}} = -40^{\circ}\text{C}$	160mA	1000 hours	0/22
5	Temperature Humidity Operating Life	JESD22-A101C	$T_{\text{sp}} = 85^{\circ}\text{C}$ , RH=85%	160mA	1000 hours	0/22
6	High Temperature Operating Life	JESD22-A108D	$T_{\text{sp}} = 105^{\circ}\text{C}$	240mA	1000 hours	0/22
7	Power switching	IEC62717:2014	$T_{\text{sp}} = 105^{\circ}\text{C}$ 30 sec on, 30 sec off	240mA	30000 cycles	0/22
8	Thermal Shock	JESD22-A106B	$T_{\text{a}} = -40^{\circ}\text{C} \sim 100^{\circ}\text{C}$ ; Dwell : 15min; Transfer: 10sec	-	200 cycles	0/22
9	Temperature Cycle	JESD22-A104E	$T_{\text{a}} = -40^{\circ}\text{C} \sim 100^{\circ}\text{C}$ ; Dwell at extreme temperature: 15min; Ramp rate < $105^{\circ}\text{C}/\text{min}$	-	200 cycles	0/22
10	Electrostatic Discharge	JS-001-2012	HBM, 2kV, 15k $\Omega$ , 100pF, Alternately positive or negative	-	-	0/22

## Passing Criteria

Item	Symbol	Test Condition	Passing Criteria
Forward Voltage	Vf	160mA	$\Delta V_f < 10\%$
Luminous Flux	Fv	160mA	$\Delta F_v < 30\%$
Chromaticity Coordinates	(x, y)	160mA	$\Delta u'v' < 0.007$

Notes for Table 9:

- Measurements are performed after allowing the LEDs to return to room temperature
- $T_{\text{slid}}$  : reflow soldering temperature;  $T_{\text{a}}$  : ambient temperature

# Reflow Characteristics

Figure 12 : Reflow Profile

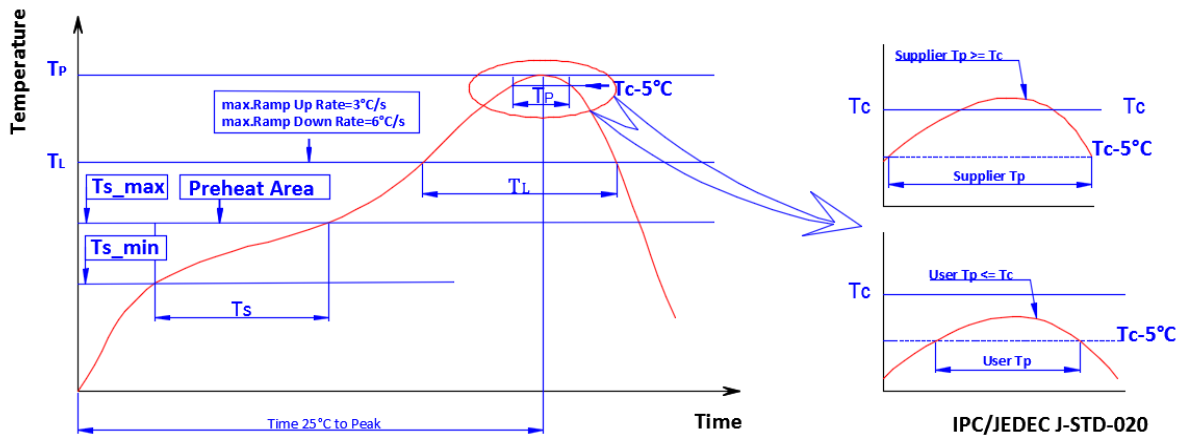

Profile Feature	Lead Free Assembly
Temperature Min. (Ts_min)	160°C
Temperature Max. (Ts_max)	205°C
Time (ts) from Ts_min to Ts_max	60-150 seconds
Ramp-Up Rate (TL to Tp)	3 °C/second
Liquidus Temperature (TL)	220 °C
Time (TL) Maintained Above TL	60-150 seconds
Peak Temp( Tp)	260 °C max.
Time (Tp) Within 5 °C of the Specified Classification Temperature (Tc)	25 seconds max.
Ramp-Down Rate (Tp to TL)	5 °C/second max.
Time 25 °C to Peak Temperature	10 minutes max.

Figure 13: Pick and Place

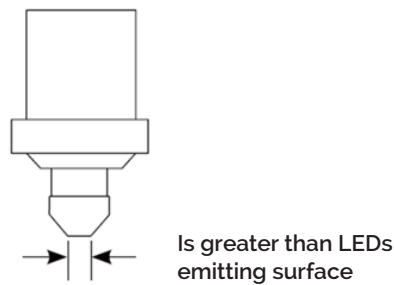

Note for Figure 13:

1. When using a pick and place machine, choose a nozzle that has a larger diameter than the LED's emitting surface. Using a Pick-and-Place nozzle with a smaller diameter than the size of the LEDs emitting surface will cause damage and may also cause the LED to not illuminate.

# Packaging

**Figure 14: Emitter Reel Drawings**

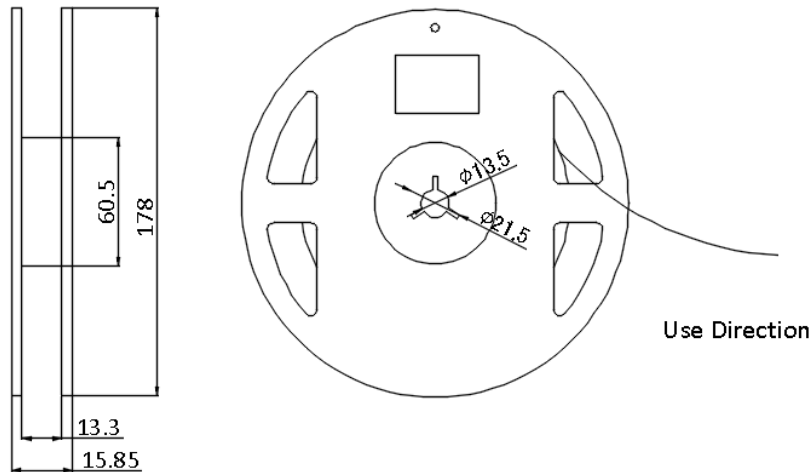

Note for Figure 14:

1. Drawings are not to scale. Drawing dimensions are in millimeters.

**Figure 15: Emitter Tape Drawings**

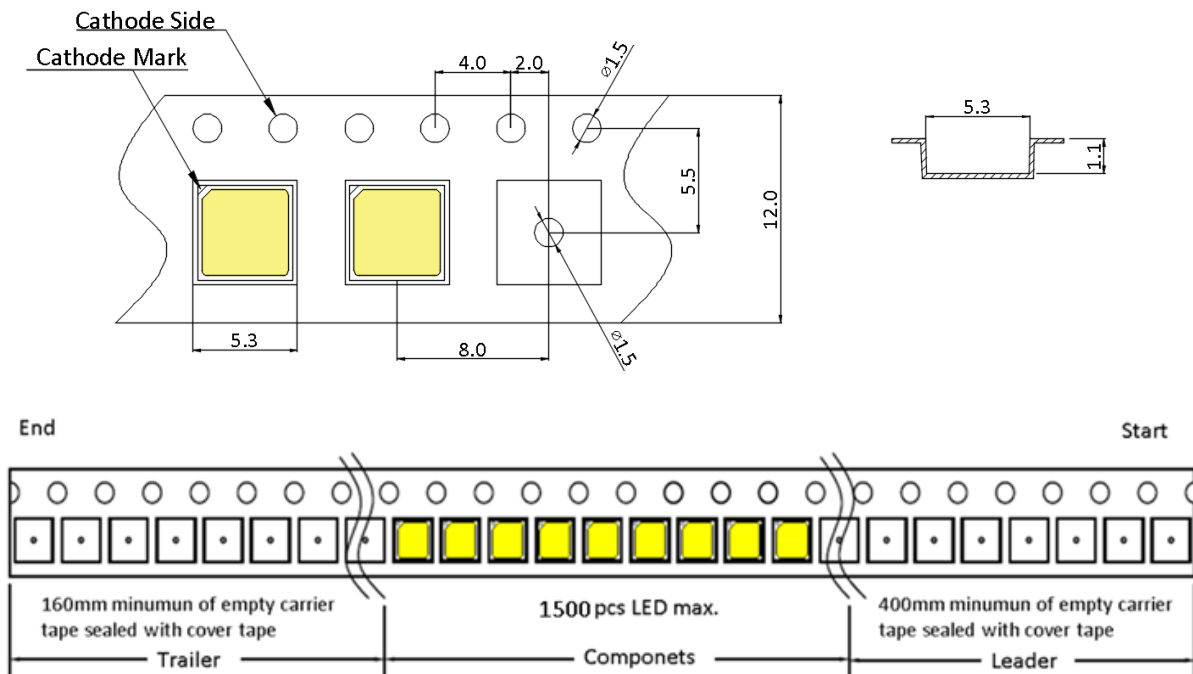

Note for Figure 15:

1. Drawings are not to scale. Drawing dimensions are in millimeters.

# Packaging

Figure 16: Emitter Reel Packaging Drawings

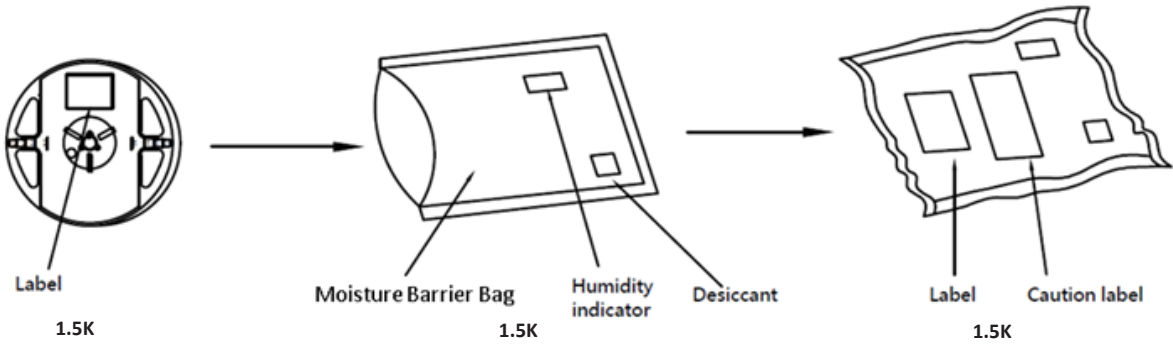

Note for Figure 16:  
1. Drawings are not to scale.

# Design Resources

Please contact your Bridgelux sales representative for assistance.

## Precautions

### **CAUTION: CHEMICAL EXPOSURE HAZARD**

Exposure to some chemicals commonly used in luminaire manufacturing and assembly can cause damage to the LED emitter. Please consult Bridgelux Application Note AN51 for additional information.

### **CAUTION: EYE SAFETY**

Eye safety classification for the use of Bridgelux SMD LED emitter is in accordance with IEC specification EN62471: Photobiological Safety of Lamps and Lamp Systems. SMD LED emitters are classified as Risk Group 2 when operated at or below the maximum drive current. Please use appropriate precautions. It is important that employees working with LEDs are trained to use them safely.

### **CAUTION: RISK OF BURN**

Do not touch the SMD LED emitter during operation. Allow the emitter to cool for a sufficient period of time before handling. The SMD LED emitter may reach elevated temperatures such that could burn skin when touched.

## CAUTION

### **CONTACT WITH LIGHT EMITTING SURFACE (LES)**

Avoid any contact with the LES. Do not touch the LES of the emitter or apply stress to the LES (yellow phosphor resin area). Contact may cause damage to the emitter

Optics and reflectors must not be mounted in contact with the LES (yellow phosphor resin area).

## Disclaimers

### **MINOR PRODUCT CHANGE POLICY**

The rigorous qualification testing on products offered by Bridgelux provides performance assurance. Slight cosmetic changes that do not affect form, fit, or function may occur as Bridgelux continues product optimization.

### **STANDARD TEST CONDITIONS**

Unless otherwise stated, LED emitter testing is performed at the nominal drive current.



# About Bridgelux: Bridging Light and Life™

At Bridgelux, we help companies, industries and people experience the power and possibility of light. Since 2002, we've designed LED solutions that are high performing, energy efficient, cost effective and easy to integrate. Our focus is on light's impact on human behavior, delivering products that create better environments, experiences and returns—both experiential and financial. And our patented technology drives new platforms for commercial and industrial luminaires.

**For more information about the company, please visit**  
**bridgelux.com**  
**twitter.com/Bridgelux**  
**facebook.com/Bridgelux**  
**youtube.com/user/Bridgelux**  
**https://www.linkedin.com/company/bridgelux-inc-\_2**  
**WeChat ID: BridgeluxInChina**



46410 Fremont Boulevard  
Fremont, CA 94538, USA  
Tel (925) 583-8400  
**www.bridgelux.com**

© 2023 Bridgelux, Inc. All rights reserved 2023. Product specifications are subject to change without notice. Bridgelux and the Bridgelux stylized logo design are registered trademarks of Bridgelux, Inc. All other trademarks are the property of their respective owners.