

700V 7A N-Channel Super Junction Power MOSFET

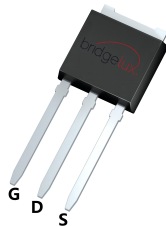
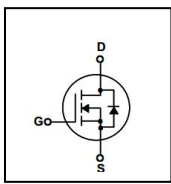
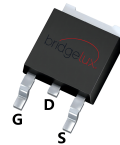
FEATURES

- $R_{DS(ON)} \leq 0.65 \Omega$ @ $V_{GS}=10V, I_D=3.5A$
- Excellent $R_{DS(ON)}$ and Low Gate Charge
- Fast switching capability
- Lead free product is acquired

Applications

- Switch Mode Power Supply (SMPS)
- Uninterruptible Power Supply (UPS)
- Power Factor Correction (PFC)

SYMBOL


TO-251L

TO-252

TO-220F

ASSEMBLY MESSAGE

Product Name	Package	Packaging
BXC70R650U	TO-251L	Tube
BXC70R650D	TO-252	Tube/Reel
BXC70R650F	TO-220F	Tube

ABSOLUTE MAXIMUM RATINGS ($T_C=25^\circ\text{C}$ unless otherwise noted)

Parameter		Symbol	Rating		Unit
			BXC70R650U/D	BXC70R650F	
Drain-Source Voltage		V_{DSS}	700		V
Drain Current	Continuous ($T_C = 25^\circ\text{C}$)	I_D	7		A
	Continuous ($T_C = 100^\circ\text{C}$)		5.6		A
Drain Current	Pulsed (Note1)	I_{DM}	28		A
Gate-Source Voltage		V_{GSS}	± 30		V
Avalanche Energy	Single Pulse (Note2)	E_{AS}	120		mJ
Avalanche Current (Note1)		I_{AR}	1.2		A
Power Dissipation (Note 2)	$T_C = 25^\circ\text{C}$	P_D	62.5	31.25	W
	Derate above 25°C		0.5	0.25	W/ $^\circ\text{C}$
Maximum Junction Temperature		T_J	150		$^\circ\text{C}$
Storage Temperature Range		T_{STG}	-55 to 150		$^\circ\text{C}$

Note: 1. Limited by maximum junction temperature, maximum duty cycle is 0.75
 2. $L=3\text{mH}$, $V_{DD}=50\text{V}$, $R_G=25 \Omega$, Starting $T_J = 25^\circ\text{C}$

THERMAL CHARACTERISTICS

Parameter	Symbol	Max.		Unit
		BXC70R650U/D	BXC70R650F	
Thermal Resistance, Junction-to-Case	$R_{\theta JC}$	2	4	°C / W
Thermal Resistance, Junction-to-Ambient	$R_{\theta JA}$	62	68	°C / W

ELECTRICAL CHARACTERISTICS ($T_J=25^{\circ}\text{C}$, unless otherwise Noted)

Parameter	Symbol	Test Condition	Min.	Typ.	Max.	Unit
OFF CHARACTERISTICS						
Drain-Source Breakdown Voltage	BV_{DSS}	$V_{GS}=0V, I_D=250\mu A$	700			V
Zero Gate Voltage Drain Current	I_{DSS}	$V_{DS}=700V, V_{GS}=0V$			1	μA
		$V_{DS}=560V, T_C = 125^{\circ}\text{C}$		10		μA
Gate-Body Leakage Current, Forward	I_{GSS}	$V_{GS}=30V$			100	nA
Gate-Body Leakage Current, Reverse		$V_{GS}=-30V$			-100	nA
ON CHARACTERISTICS						
Gate Threshold Voltage	$V_{GS(TH)}$	$V_{DS}=V_{GS}, I_D=250\mu A$	2.5		4.0	V
Drain-Source On-State Resistance	$R_{DS(ON)}$	$V_{GS}=10V, I_D=3.5A$		0.56	0.65	Ω
DYNAMIC PARAMETERS						
Input Capacitance	C_{ISS}	$V_{DS}=100V, V_{GS}=0V,$ $f=1.0\text{MHz}$		498		pF
Output Capacitance	C_{OSS}			23		pF
Reverse Transfer Capacitance	C_{RSS}			1.6		pF
SWITCHING PARAMETERS						
Turn-ON Delay Time	$t_{D(ON)}$	$V_{DD}=400V, I_D=3.5A, V_{GS}$ $= 10V, R_G=25\Omega$		12		ns
Turn-ON Rise Time	t_R			22		ns
Turn-OFF Delay Time	$t_{D(OFF)}$			50		ns
Turn-OFF Fall-Time	t_F			37		ns
Total Gate Charge(Note5)	Q_G	$V_{DD} = 560V, V_{GS} = 10V, I_D$ $= 3.5A$		13		nC
Gate Source Charge	Q_{GS}			3		nC
Gate Drain Charge	Q_{GD}			5		nC
SOURCE- DRAIN DIODE RATINGS AND CHARACTERISTICS						
Drain-Source Diode Forward Voltage	V_{SD}	$I_F=3.5A, V_{GS}=0V$		0.85		V
Diode Continuous Forward Current	I_S				7	A
Pulsed Drain-Source Current	I_{SM}				28	A
Reverse Recovery Time	t_{RR}	$V_R = 400 V, I_F = 3.5A$ $di/dt=100 A/\mu s$		200		ns
Reverse Recovery Charge	Q_{RR}			1.3		μC

TYPICAL CHARACTERISTICS

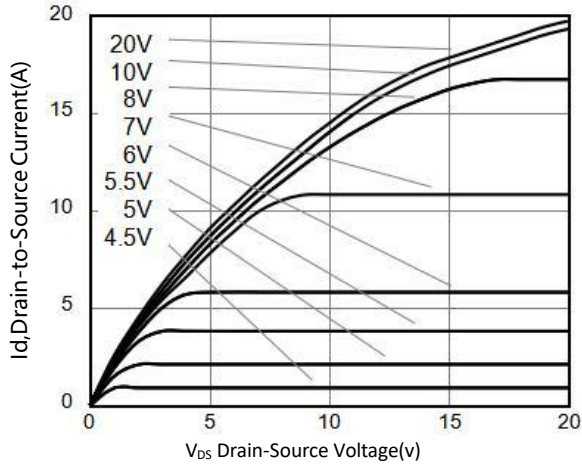


Figure1. Typical Output Characteristics

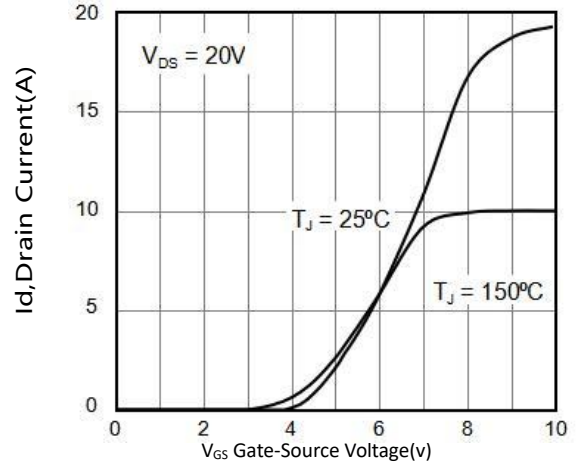


Figure2. Typical Transfer Characteristics

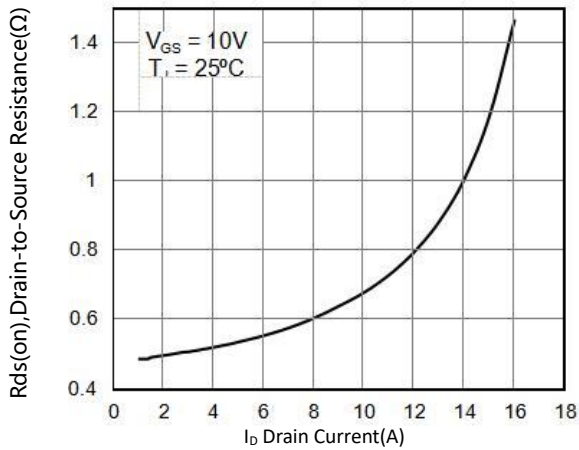


Figure3. On-Resistance versus Drain Current

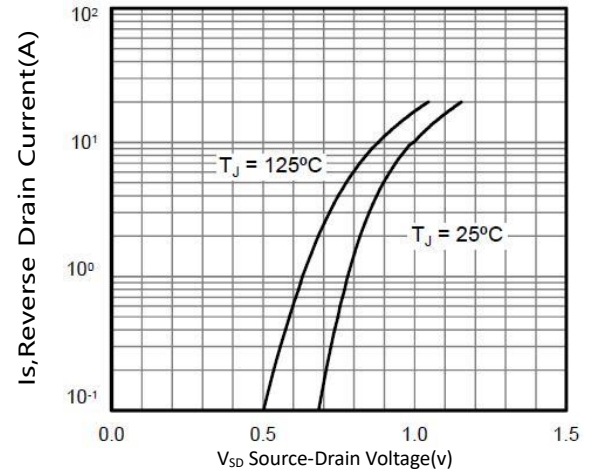


Figure4. Diode forward voltage versus Current

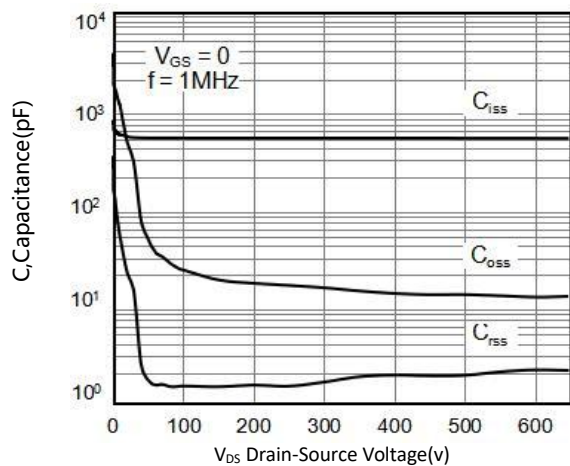


Figure5. Typical Capacitance versus VDS

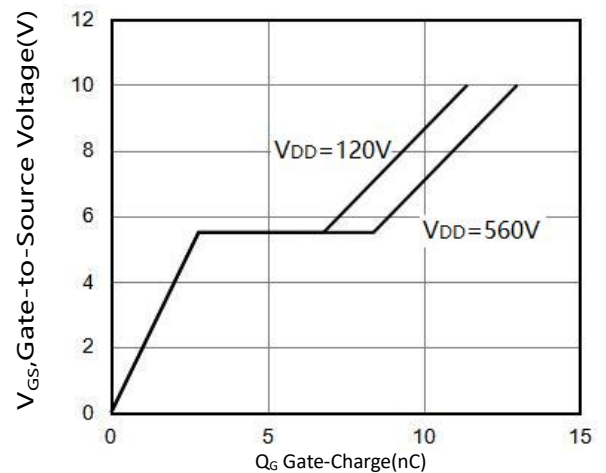


Figure6. Typical Gate Charge versus VGS

TYPICAL CHARACTERISTICS(Cont.)

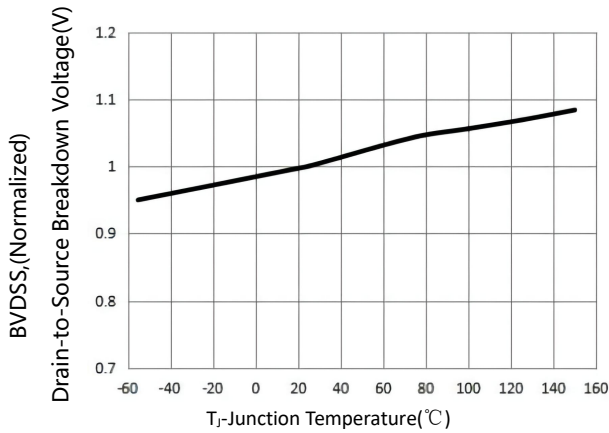


Figure7. BV_{DSS} Variation with Temperature

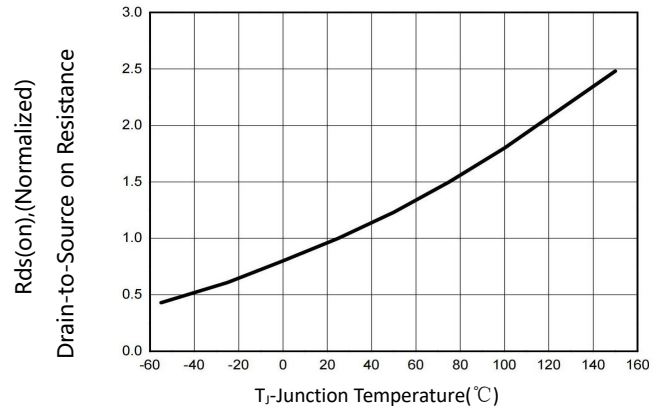
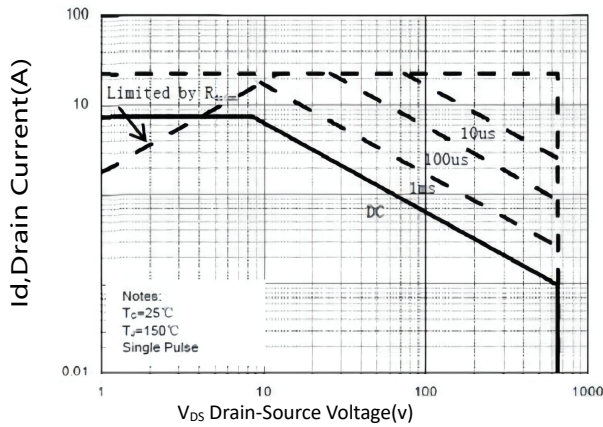
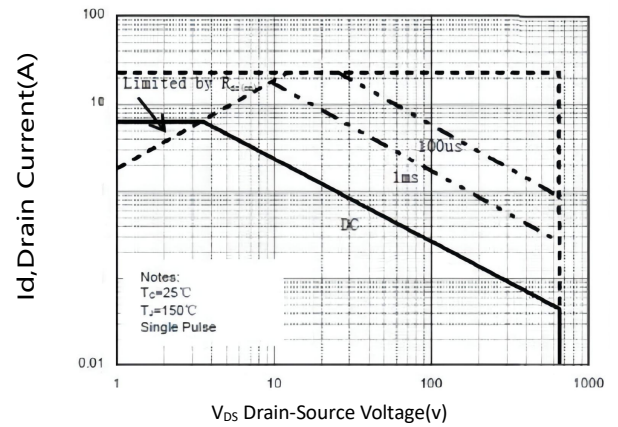


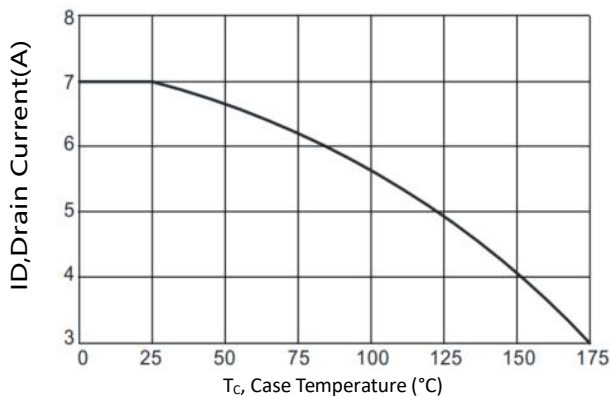
Figure8. On-Resistance Variation with Temperature



**Figure9. Maximum Safe Operating Area
BXC70R650U/D**

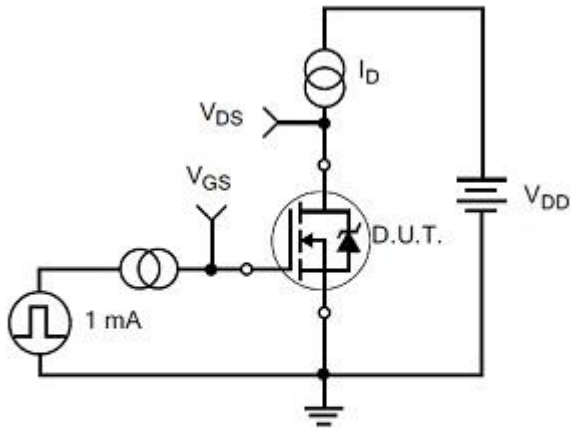


**Figure9. Maximum Safe Operating Area
BXC70R650F**

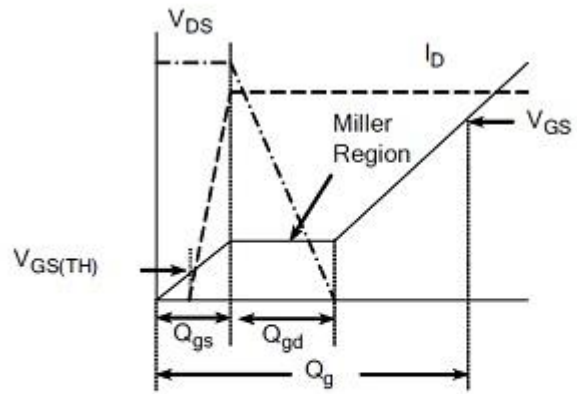


**Figure10. Maximum Continuous Drain Current
versus Case Temperature**

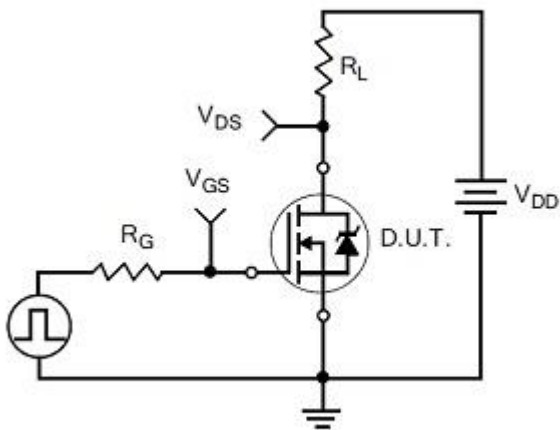
TEST CIRCUITS AND WAVEFORMS



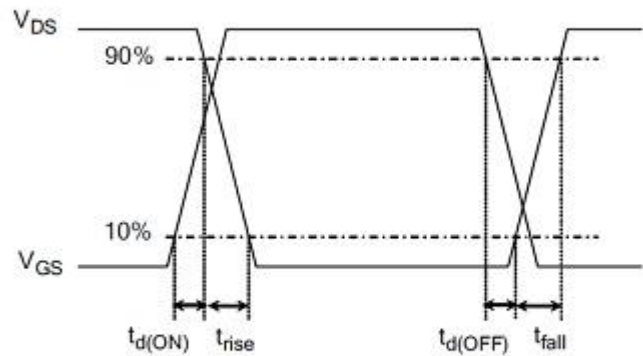
Gate Charge Test Circuit



Gate Charge Waveform

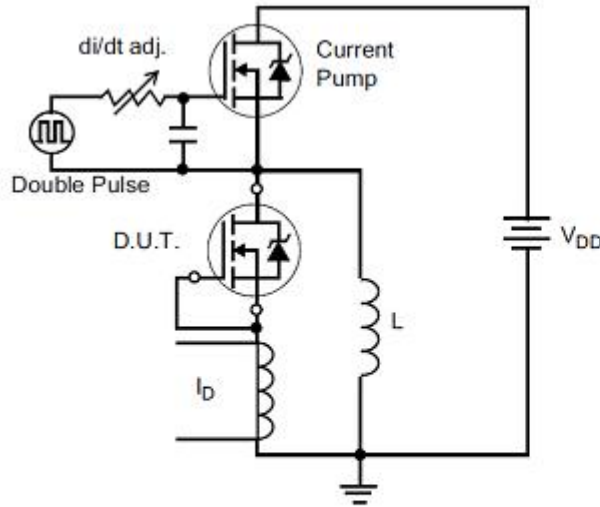


Resistive Switching Test Circuit

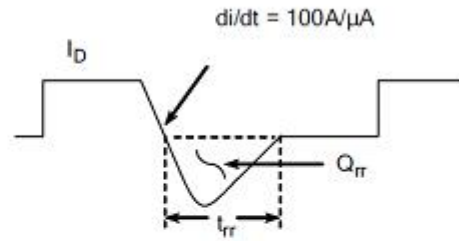


Resistive Switching Waveforms

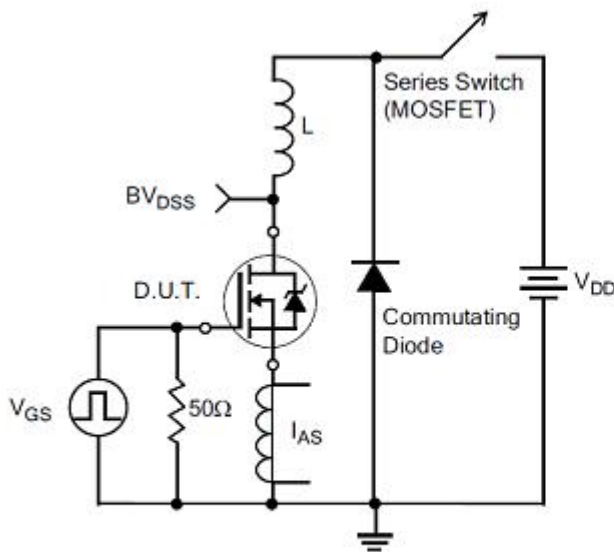
TEST CIRCUITS AND WAVEFORMS(Cont.)



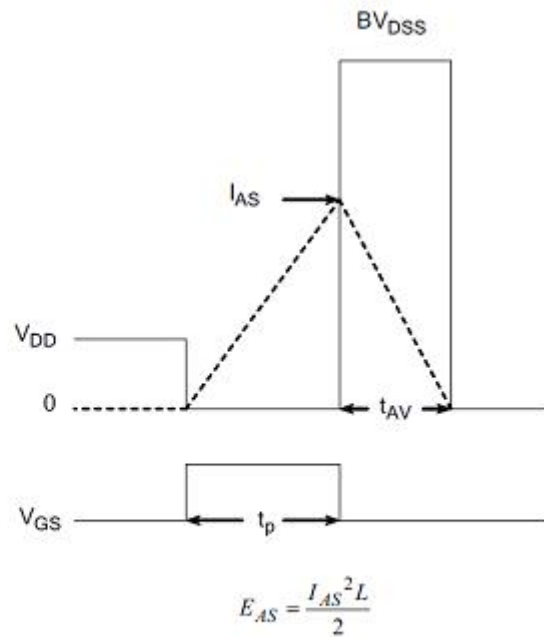
Diode Reverse Recovery Test Circuit



Diode Reverse Recovery Waveform



Unclamped Inductive Switching Test Circuit



Unclamped Inductive Switching Waveforms

Revision history

Document revision history

Date	Revision	Changes
20-Sep-2021	1.0	First release

Disclaimers:

Bridgelux WuXi has made reasonable commercial efforts to ensure that the information given in this data sheet is correct. However, it must clearly be understood that such information is for guidance only and does not constitute any representation or form part of any offer or contract.

For documents and material available from this data sheet, Bridgelux WuXi does not warrant or assume any legal liability or responsibility for the accuracy, completeness, or usefulness of any information, product, technology or process disclosed hereunder.

Bridgelux WuXi reserves the rights to at its own discretion to make any changes or improvements to this data sheet. Unless said data sheet is incorporated into the formal contract, any customer should not rely on the information as any specification or product parameters duly committed by Bridgelux WuXi. Customers are hereby advised to verify that the information contained herein is current and complete before the entering of any contract or acknowledgement of any purchase order. Accordingly, all products specified hereunder shall be sold subject to Bridgelux WuXi's terms and conditions supplied at the time of order acknowledgement. Except where agreed upon by contractual agreement, testing of all parameters of each product is not necessarily performed.

Bridgelux WuXi does not warrant or convey any license either expressed or implied under its patent rights, nor the rights of others. Reproduction of information contained herein shall be only permissible if such reproduction is without any modification or alteration. Reproduction of this information with any alteration is an unfair and deceptive business practice. Bridgelux WuXi is not responsible or liable for such altered documentation.

Resale of Bridgelux WuXi's products with statements different from or beyond the parameters stated by Bridgelux WuXi for that product or service voids all express or implied warranties for the associated Bridgelux WuXi's product or service and is unfair and deceptive business practice. Bridgelux WuXi is not responsible or liable for any such statements.

Bridgelux WuXi's products are not authorized for use as critical components in life support devices or systems without the express written approval of Bridgelux WuXi. As used herein:

1. Life support devices or systems are devices or systems which, (a) are intended for surgical implant into the body, or (b) support or sustain life, and whose failure to perform, when properly used in accordance with instructions for use provided in the labeling, can be reasonably expected to result in a significant injury to the user.
2. A critical component is any component of a life support device or system whose failure to perform can be reasonably expected to cause the failure of the life support device or system, or to affect its safety or effectiveness.