

Application Note AN36

Optical Considerations for Bridgelux Vero Series LED Arrays

May 28, 2013

Introduction

The Bridgelux family of Vero Array products delivers high performance, compact, and cost-effective solid-state lighting solutions to serve the general lighting market. These products combine the higher efficiency, lifetime, and reliability benefits of LEDs with the light output levels of many conventional lighting sources.

Optimizing performance and reliability of a lighting system using Bridgelux Vero Series LED Arrays requires careful consideration of thermal management solutions, handling and assembly, selection of electronic drivers and selection of secondary optics. Application Notes AN30, AN31, AN32 and AN36 respectively deal with each of these topics in depth. To achieve optimal performance of the LED Arrays, proper thermal management must be selected or designed.

Bridgelux Vero Arrays have been uniquely designed to produce a wide and smooth Lambertian light emission pattern suitable for a wide variety of lighting applications. Some applications, however, may require a different distribution of light. Secondary optics components such as lenses, reflectors or collimators can be used to create a wide variety of optical effects in order to meet specific lamp and luminaire design requirements.

The purpose of this application note is to provide a general understanding of basic optical concepts that can be used to modify the spatial light distribution produced by Bridgelux Vero Arrays and guidance as to how to change the light distribution to meet application driven requirements. Included in this note is an overview of geometric optics, a description of Bridgelux Vero Array optical performance, guidelines for specifying optical performance requirements, and information regarding commercially available secondary optics for use with Bridgelux Vero Arrays. A list of companies specializing in the development and manufacturing of custom optics is also included to assist customers with needs for unique optical solutions.



Table of Contents

Page

Geometric Optics and Light Propagation	3
Bridgelux Vero Array Optical Performance	11
Specifying Optical Performance	14
Optics Design and Selection Considerations	17
Commercially Available Optics for Bridgelux Vero Arrays	20
Custom Optics	21
Design Resources	22

Geometric Optics and Light Propagation

The science of optics is the study of the properties and behavior of light. Although visible light is an electromagnetic wave with both wave-like and particle-like properties, simplified models can be used to describe the general properties of light. One such model is that of geometric optics, which describes light as rays that travel in straight lines (Figure 1) and bend as they pass through or reflect from surfaces in their path. In this model variability which may be caused by the wavelength of the light is considered negligible compared to the dimensions of the optical components comprising the system.

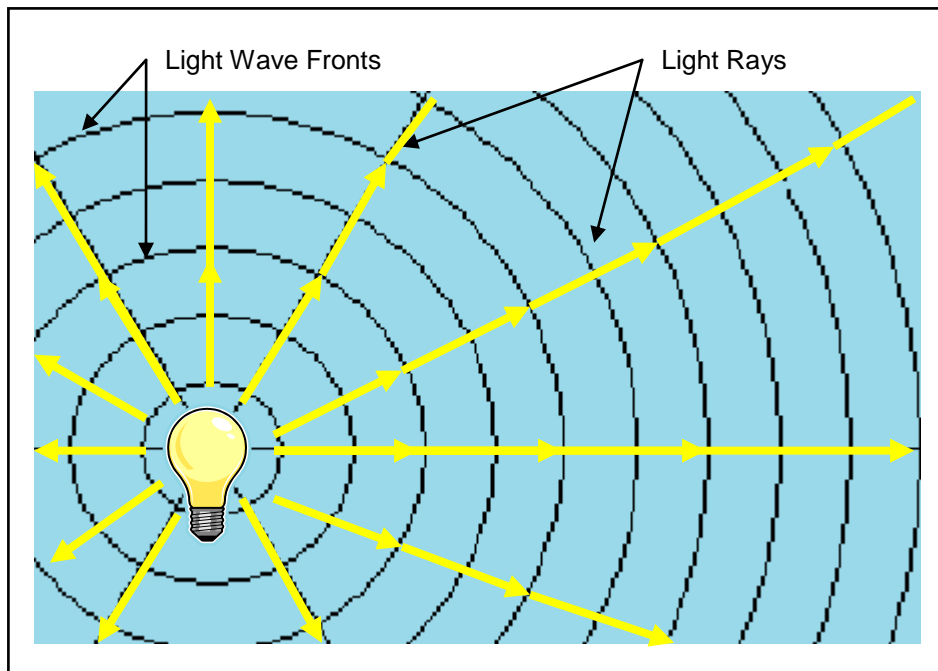

Figure 1: Light source, light rays and light wave fronts

Some of the basic concepts used to describe light propagation in geometric optics are reflection, refraction, absorption, and transmission. These concepts are illustrated in Figure 2.

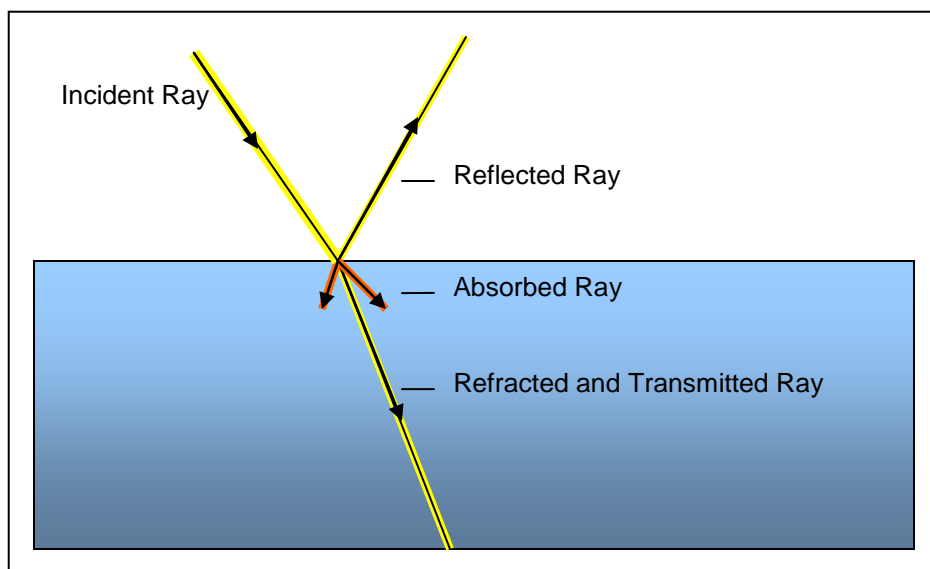

Figure 2: A ray of light moving between mediums may be reflected, refracted and transmitted, or absorbed

Reflection

Reflection occurs when a ray of light impacts a surface, changing the direction of light travel. The law of reflection states that the direction of the incident ray and the angle of the reflected ray with respect to the normal are the same (Figure 3). The normal is a line perpendicular to the surface at the location of impact of the light ray.

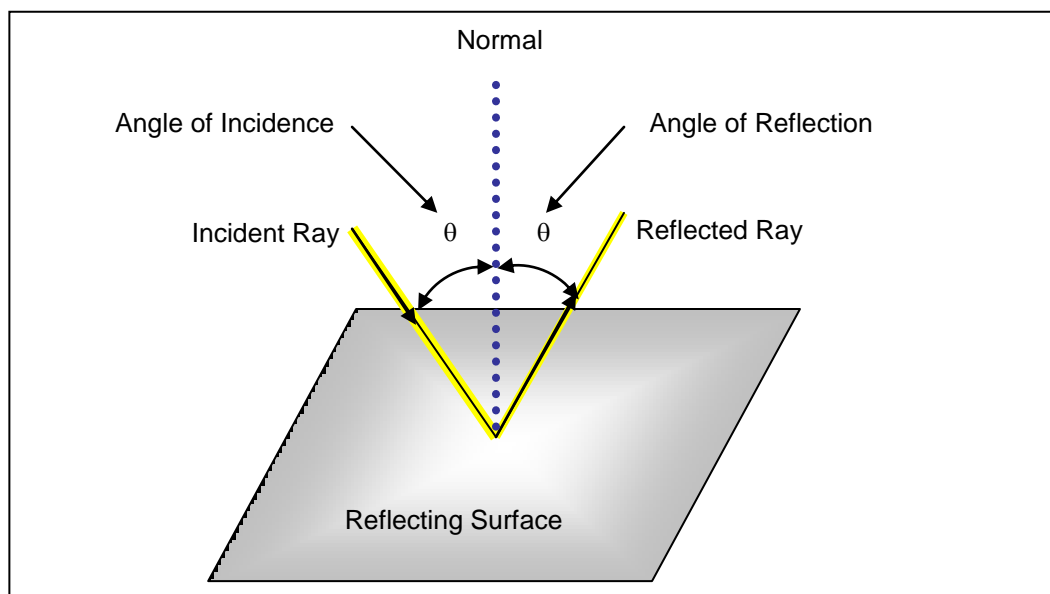

Figure 3: Graphical depiction of the law of reflection

Commonly recognized reflective surfaces are mirrors, which are specular or polished. However not all reflective surfaces have specular finishes; spread reflectors have rough surfaces and diffuse reflectors have matte surfaces. Figure 4 shows a close-up of a diffuse or scattering reflective surface, illustrating the variability of the path of reflection based on variability in the reflecting surface. Diffuse or scattering reflectors can be very efficient at reflecting light (high efficiency) but effectively mix the reflected rays to provide a smooth appearance. A diffuse reflector will not produce a hot spot in the beam pattern but may deliver very high beam uniformity and light quality, avoiding color separation which may occur with a specular reflector.

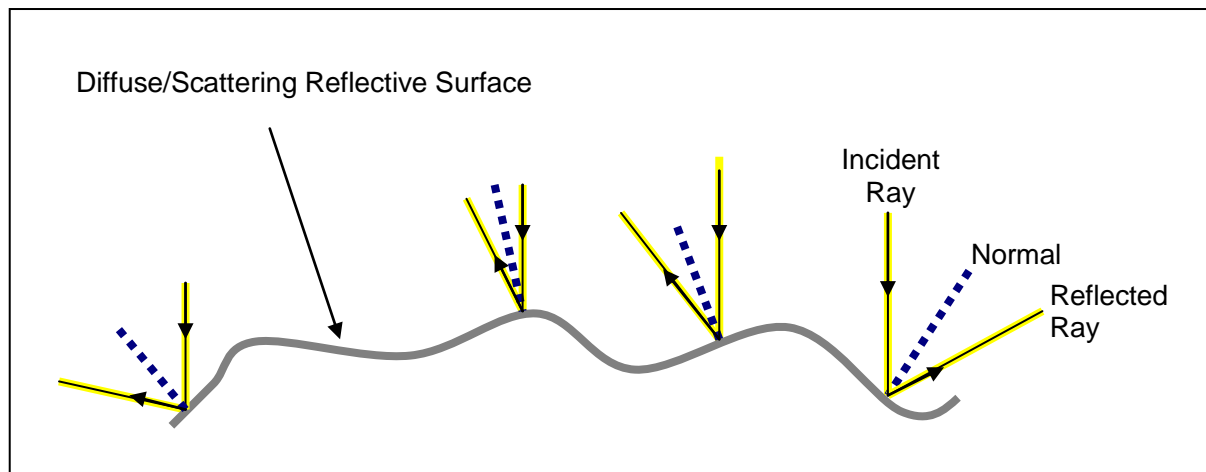

Figure 4: Diffuse reflective surfaces scatters light rays in multiple directions

Reflectivity of materials can vary significantly. When designing an optical system that includes reflective components (such as using a reflector), select materials with high reflectivity in the visible spectrum. Table 1 indicates the variability in various reflective materials, both total reflectivity and diffuse reflectivity.

Reflective Material	Minimum Total Reflectivity (%)	Diffuse Reflectivity (%)
Anolux Stucco Miro 9	95	94
Labsphere 6080 Coating (white)	98	98
Dull Aluminum Foil	80	-
Bright Aluminum Foil	88	-
White Household Paint	60 to 85	60 to 85
White97 F23A Film	97	97

Table 1: Reflectivity of various materials

Reflection is responsible for narrowing or tightening of the light distribution. Reflectors with polished and continuous surfaces tend to have imaging effects, while reflectors with faceted surfaces break up the image and soften the light distribution.

Reflection is also responsible for some of the optical losses observed when a clear cover is placed over a light source, such as an exterior cover on a lamp or luminaire. Even with a highly transparent material losses on the order of 5% per surface are common, due primarily to reflection. A typical cover will cause the light to travel through two surfaces resulting in a 10% loss of light.

Refraction

Refraction describes the bending (or changing direction) of light as it moves from one medium to another, such as a beam entering a lens from air. Refraction is caused by differences in material properties between the two mediums that cause a change to the speed of the light wave. Snell's Law is used to describe refraction, stating that the angle of incidence is related to the angle of refraction by the following equation:

$$\frac{\sin \theta_1}{\sin \theta_2} = \frac{v_1}{v_2} = \frac{n_2}{n_1}$$

Where:

v_1 and v_2 are the wave velocities through the respective media

θ_1 and θ_2 are the angles between the normal (to the interface) plane and the incident waves respectively

n_1 and n_2 are the refractive indices of the respective media

Equation 1: Snell's Law

All angles shown are relative to the normal, a line perpendicular to the interface surface, indicated by a dashed line in Figure 5.

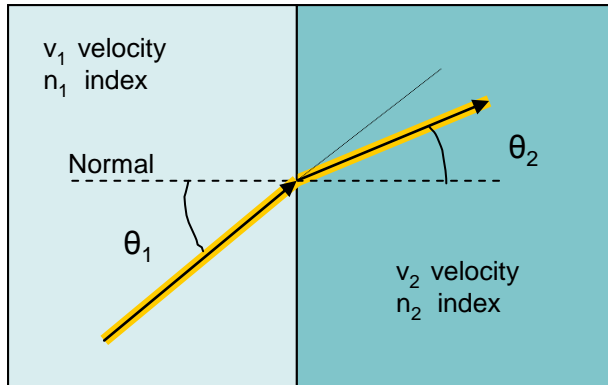

Figure 5: Illustration of refraction

The severity to which the light ray bends depends on the difference in index of refraction between the two mediums through which the light travels. Table 2 includes the index of refraction values of several common optical materials.

Material	Index of Refraction
Air	1.00028
Crown Glass	1.50 – 1.62
PMMA	1.489
Water	1.33

Table 2: Index of refraction of various materials

Refraction is responsible for the image formation that occurs when a lens is used. Figure 6 shows examples of two common lenses and their optical effects.

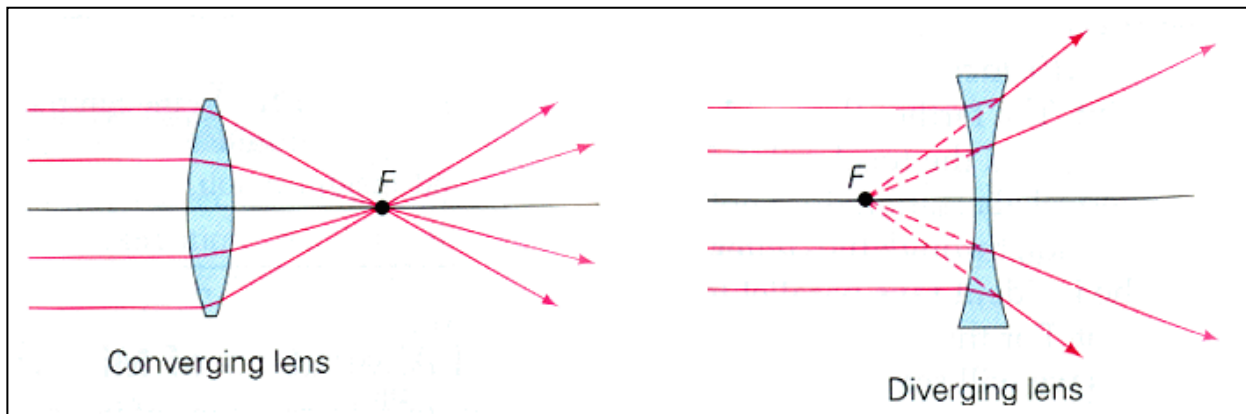

Figure 6: Examples of common lenses: a converging lens focuses parallel rays to a focal point (F), a diverging lens has the opposite effect

The lens examples in Figure 6 either magnify or shrink the image. These types of optics are referred to as imaging optics. In general it is not recommended to use imaging optics with Bridgelux Vero Arrays. An imaging optic requires extremely precise design and positioning of the optic as there is only one focal point for the lens at which a good image will be maintained. At any distance other than the focal distance the light will be distorted which may result in a non-uniform image, causing undesired optical effects.

Total Internal Reflection

As mentioned previously, when a light ray strikes a surface the light may be reflected, refracted, absorbed, or a combination of these three effects. Depending on the angle of incidence, however, it is possible for a light ray striking a medium with a lower index of refraction to be totally reflected, an effect known as Total Internal Reflection (TIR).

When a ray of light moves from a material with a higher index of refraction to a material with a lower index of refraction, the ray bends away from the normal. Using Snell's law we may calculate the incident angle which will result in the light ray bending to 90 degrees from the normal, resulting in a light ray traveling along the surface of the interface of the two mediums. This incident angle is referred to as the critical angle, θ_c . Light which is incident at any angle less than the critical angle may be partially reflected within the first medium and partially refracted and transmitted to the second medium. Light which is incident at any angle greater than θ_c is totally reflected within the first medium. Figure 7 illustrates this effect. The principle of TIR is used for fiber optics systems where the light reflects (TIRs) off the side wall of the fiber allowing it to transmit through the length of the fiber rather than exiting at the circumference.

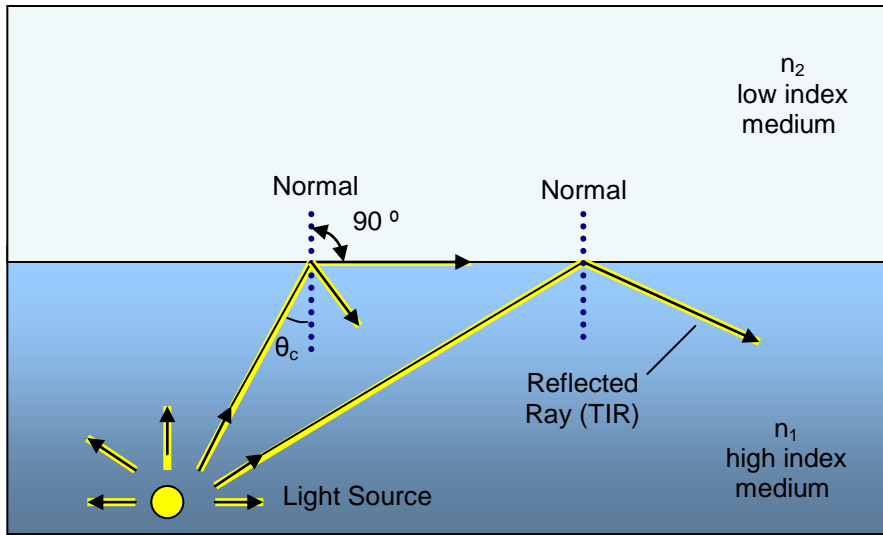

Figure 7: Critical angle and internal reflection

This concept of TIR is commonly used in designing optics, such as collimators, for LEDs (Figure 8). Collimators are typically molded from transparent materials and condense broad light distributions into tighter collimated beams. The side walls of the collimator redirect light upward using TIR, in a manner similar to a reflector.

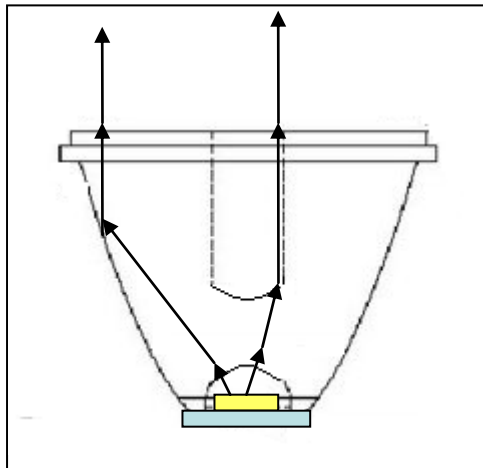

Figure 8: Illustration of a TIR collimating optic

Collimators for larger optical source sizes, such as that of some of the Bridgelux Vero Arrays, can become quite large to capture and redirect the light with a high degree of efficiency. As these are optically molded components, this can result in long cycle times and high costs. Therefore typically reflectors rather than collimators are used for optical management of Bridgelux Vero Arrays.

Absorption

Rays of light passing through a medium attenuate. One reason for this is that light may be absorbed and transformed into other forms of energy, such as heat. The degree of absorption is described by the law of absorption, shown in Equation 2.

$$d\Phi = -\alpha\Phi_0 dx$$

Where:

dx is the distance through the material that the light travels
 $d\Phi$ is the change of power of the light when it exits the material
 Φ_0 is the power of the light entering the material
 α is the absorption coefficient

Equation 2: Law of Absorption

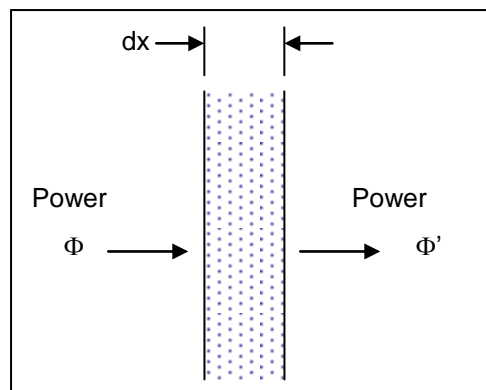

Figure 9: Illustration of the variables effecting absorption

When designing or selecting an optical system, select materials that have low levels of visible light absorption. Minimizing the distance (dx) that the light travels through light absorbing materials will also reduce absorption.

Bridgelux Vero Array Optical Performance

The light distribution emitted from Bridgelux Vero Arrays may be described in different ways. Using geometric optics the light may be described using rays. Rays of light near the Vero Array are referred to as near field. Rays in the near field may cross, resulting in changing patterns of light in this region. Rays of light at a distance far from the source are referred to as far field. Figure 10 illustrates both near field and far field.

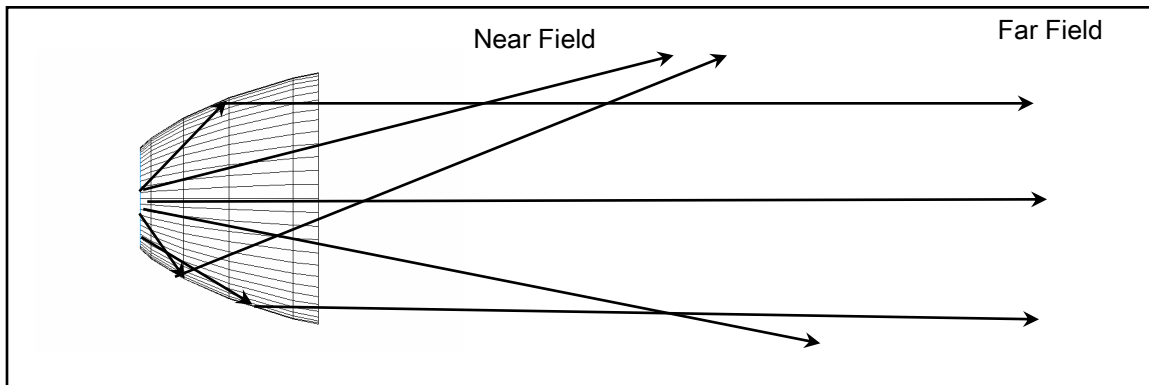

Figure 10: Near field and far field rays

Near Field

The near field is located in the area close to the emitting surface of the light source. Typically the near field is described as a distance that is less than ten times the source or aperture size. Near field light rays may cross other light rays. In contrast, far field light rays diverge and never cross one another. For Bridgelux Vero Arrays, the source size is the diameter of the resin portion of the Vero Array. If optical elements (such as a reflector or other optical component) are used to change the trajectory of the light rays, then the source size becomes the aperture of the optical element from which the rays exit. Figures 11a and 11b illustrate the source size of Bridgelux Vero Arrays with and without secondary optics.

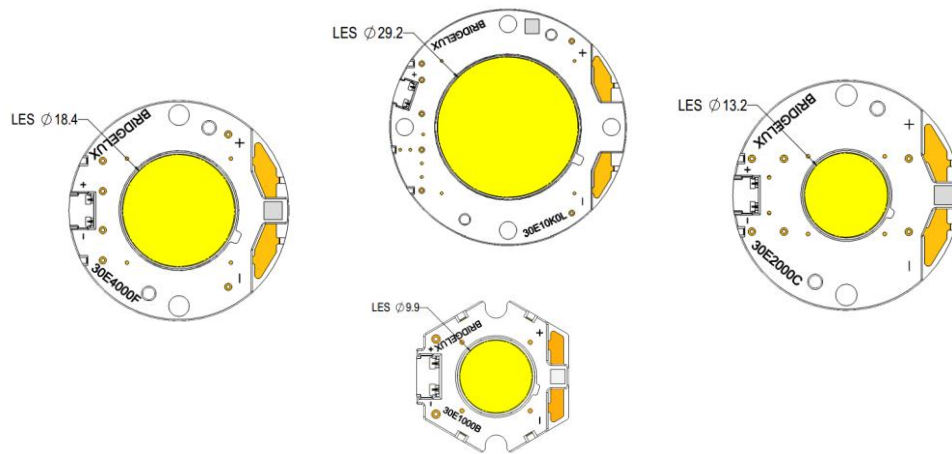

Figure 11a: Source size or light emitting surface (LES) of Bridgelux Vero Array without optics

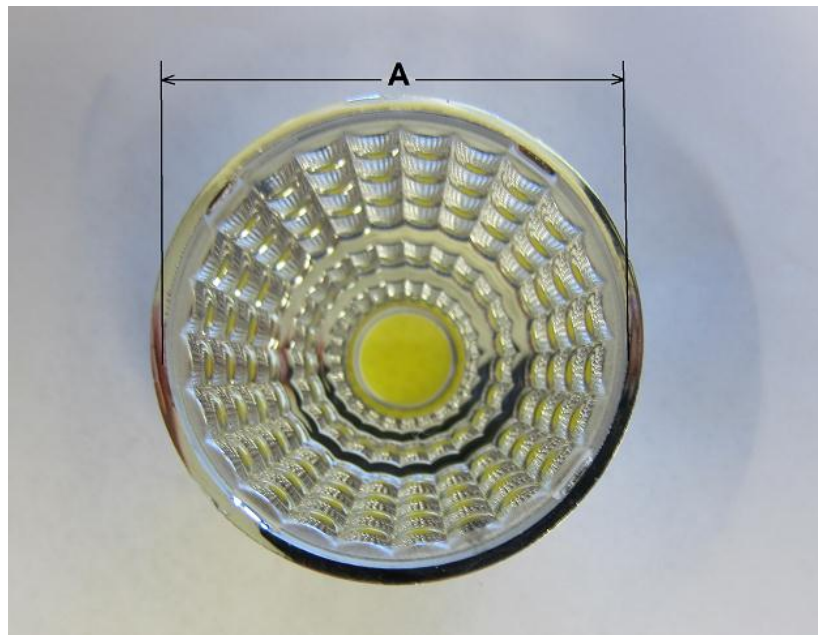

Figure 11b: Source size of a Bridgelux Vero Array with optic (diameter A)

Bridgelux Vero Arrays are not point sources. Light is emitted from the resin area of the Vero Array. Radiant Imaging Source files and raysets describe the near field light emission of Bridgelux Vero Arrays, and may be used to design optical systems. These files may be acquired from the Bridgelux website under the Design Resources section, Optical Models. Multiple formats are available for use with many commonly used optical design software programs. Bridgelux recommends using near field ray sets containing a minimum of one million rays for optical modeling and design.

Please note that the Radiant Imaging Source files generated for Bridgelux Vero arrays contain spatial color data. Many optical modeling software programs accept near field files with color information for modeling of the arrays. With the implementation of standards that require that luminaire achieve certain color angular uniformity performance criteria, use of color ray set files when optically modeling Bridgelux Vero arrays is encouraged in relevant markets.

When physically evaluating the light distribution of the Vero Array or optical system it is important to ensure that the distance at which the light pattern is evaluated is identical to that of the final use distance. For example if evaluating the performance of a street light, evaluating the light a few centimeters from the Vero Array (in the near field) would not be relevant to the actual use condition.

Far Field

The far field describes rays far from the source, at a distance described as approximately fifteen times or greater that of the source size. Rays in the far field do not cross and have stable patterns. Figure 12 shows the far field spatial distribution light produced by the Bridgelux Vero Arrays.

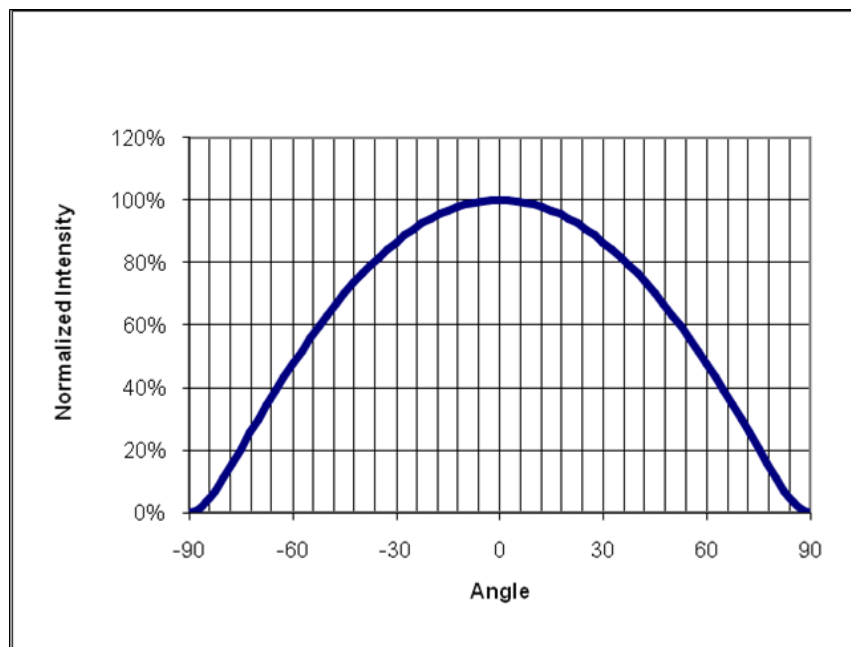

Figure 12: Typical spatial radiation pattern for Bridgelux Vero Arrays

Specifying Optical Performance

When integrating Bridgelux Vero Arrays into a lighting solution it is important to define the light distribution requirements for their application. Once the desired optical performance is defined, the need for additional optical components can be determined. If additional optical components are required, designers may first wish to evaluate off-the-shelf components to see if these available options achieve the required performance. If not, a custom optical system or component may be required.

Specifying or selection an optic for use with Bridgelux Vero Arrays first requires careful consideration as to the requirements of the optic. Defining optical performance requirements should include answering the following questions:

- What is the size of the area being illuminated?
- What is the distance between the light source and the area being illuminated?
- What level of illumination is required in the area being illuminated?
- What degree of uniformity is required in the area being illuminated?
- How much light is allowed outside of the area that is targeted to be illuminated?
- Should the transition from the illuminated area to the non illuminated area be gradual or sharp?
- What degree of color uniformity is required over the area being illuminated?

A basic familiarity with common photometric measurements is useful in describing light or light distribution requirements. Table 3 lists common photometric measurements and Figures 13a and 13b illustrate how these measurements may be used to specify lighting systems.





Photometric Measurement	Unit	Illustration
<p>Luminous Flux</p> <p>Luminous flux is the rate of flow of visible light energy</p>	<p>lumen (lm)</p>	 <p>Luminous Flux Total Power (lumen) "Light Power"</p>
<p>Luminous Intensity</p> <p>Luminous intensity is the power of a light source, or illuminated surface, to emit light in a particular direction. Luminous intensity is flux per unit solid angle.</p>	<p>candela (cd)</p> <p>1 cd = 1 lumen per solid angle (in steradian)</p>	 <p>Luminous Intensity Total Power (lumen) / Solid Angle "Candle Power"</p>
<p>Illuminance</p> <p>Illuminance is the density of luminous flux reaching a surface, or the lumens per unit area.</p>	<p>lux (lx) or foot-candle</p> <p>1 lux = 1 lumen/m²</p> <p>1 foot-candle = 1 lumen/ft²</p>	 <p>Illuminance Total Power/Unit Area "Illumination"</p>
<p>Luminance</p> <p>Also known as photometric brightness, luminance is a measure of the flux emitted from, or reflected by, a relatively flat and uniform surface. Luminance may be thought of as luminous intensity per unit area.</p>	<p>candela per square meter (cd/m²), or nit</p>	 <p>Luminance Total Power/Solid Angle/ Projected Area "Brightness"</p>

Table 3: Common photometric measurements used to specify optical performance

Flux = 8175 Lumens

Beam Angle: 115 degrees

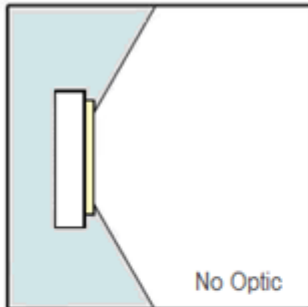

Illuminance at a Distance		
	Center Beam LUX	Beam Width
4.0M	172.59 LUX	12.8 M
8.0M	43.15 LUX	25.6 M
12.0M	19.18 LUX	38.5 M
16.0M	10.79 LUX	51.3 M
20.0M	6.90 LUX	64.1 M

Beam Angle: 30 degrees

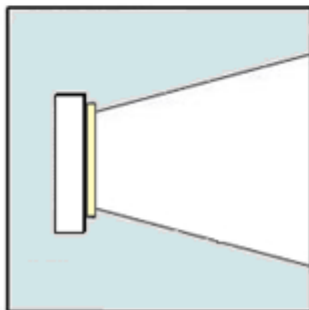

Illuminance at a Distance		
	Center Beam LUX	Beam Width
4.0M	1,061.5 LUX	2.3 M
8.0M	265.4 LUX	4.6 M
12.0M	117.9 LUX	6.9 M
16.0M	66.3 LUX	9.2 M
20.0M	42.5 LUX	11.5 M

Figure 13a: Example of a light fixture specification. Center beam illuminance values at various distances are specified. Note how the 115° and 30° beam angles generate different effected diameters and different illuminance values.

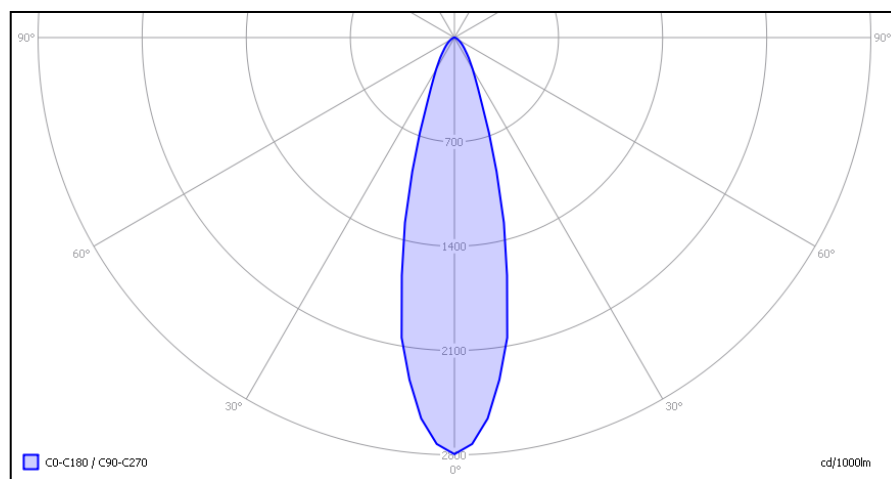

Figure 13b: Example of spatial luminous intensity performance of a luminaire.

Optic Design and Selection Considerations

Bridgelux recommends considering the following elements when selecting or designing an optic for use with Bridgelux Vero Arrays.

Efficiency

The goal of an optical component is to take light whose trajectory is away from a targeted area and redirect that light to a desired location. The optic should collect as much of the misdirected light as possible while minimizing losses that result from redirecting the light. In other words, the system optical efficiency should be maximized by minimizing optical losses. This may be achieved by both minimizing losses when light is touched by optical elements and by minimizing the number of times the light is touched or redirected.

When selecting commercially available optics it is important to understand the optical efficiency of the optical component. This efficiency may be calculated by measuring the flux from the Vero Array both with and without the optical system and comparing these values. The ratio of the light output with the optic to the light output without the optic is the efficiency of the optic. An efficient optical system should range from 85 to 95%, or higher.

Imaging vs. Non-Imaging Optics

Bridgelux recommends using optical components that do not image the light source. Imaging optics may result in undesired effects.

Optical Center

Optics should be designed to be centered relative to the optical center of the Vero Array. The optical center for the Bridgelux Vero Arrays is defined as the geometric center of the Vero Array. The dimensions and tolerances to locate the mechanical and optical center of the respective Vero Arrays relative to the mounting screw holes and other mechanical features can be found in the mechanical drawings section of the Product Data Sheets. Specific mechanical features (alignment holes), to help ensure proper centering of optics, have been provided on Vero 13, Vero 18 and Vero 29 for optics and are shown in Figure 14. These features are best suited for molded optics or optics holders and are designed to have pins inserted through them. These features should be used whenever possible to ensure correct alignment of optics.

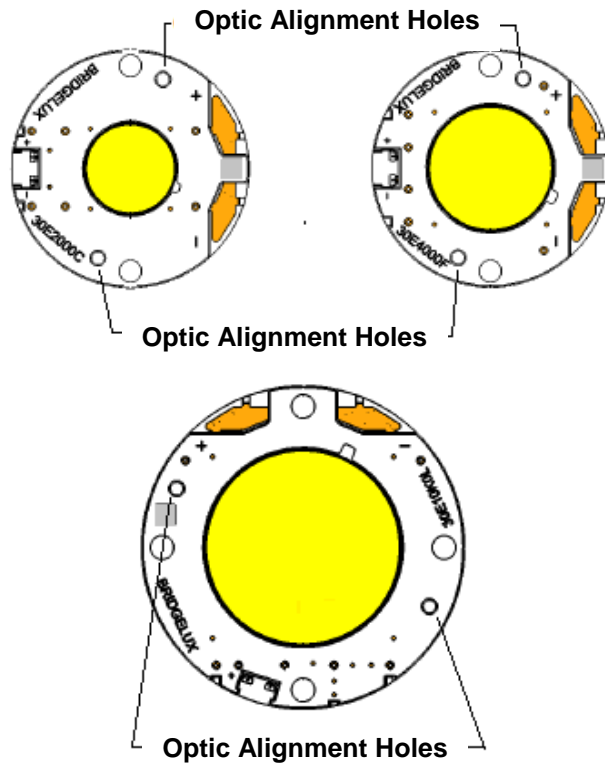

Figure 14: Optical Alignment Holes on Vero

Optic Maximum Wall Thickness at Base

Table 4 below shows the maximum space between the outer resin of the array and the mounting screw head. The wall thickness of the optic near the mounting screw head should stay below these values in order to avoid mechanical interference. Please note that the optical maximum wall thickness will vary from the value which is listed in Table 4 if the mounting screw head diameter is different than that which is listed in the table.

Table 4: Optical maximum wall thickness

Vero Array	Mounting Screw Size	Mounting Screw Head Diameter (mm)	Optical Maximum Wall Thickness (mm)
Vero10	M2.5	4.5	1.35
Vero13	M2.5	4.5	5.70
Vero18	M2.5	4.5	3.10
Vero29	M3	5.6	3.14

Mechanical Attachment of Optic

Proper placement and alignment of optical components is necessary to achieve optimal and consistent performance. Tilt of an optic or not centering the optic properly can lead to undesired lighting effects. To prevent this from occurring, ensure that the attachment of the selected optic meets manufacturer specified placement tolerances in the x, y, and z directions.

There are many ways to attach optical components to Bridgelux Vero Arrays. Some secondary optics require the use of a plastic holder or features in the optic that hold the optic in place. Optic holders may include an adhesive tape on the bottom of the holder to fix the holder in place. Mounting pins may also be included as part of the plastic optic or optic holder and these pins may be used to mechanically fix the optic/holder. These pins provide a tight and secure fit through the holes on the Vero 13, Vero 18, and Vero 29 products thereby securing the holder and optic in position.

Reflectors may be attached directly to the Vero Array without the need for a secondary holder using similar techniques. Reflectors can also be more permanently and rigidly fixed by clamping them in place using other mechanical components that comprise the lamp or luminaire assembly.

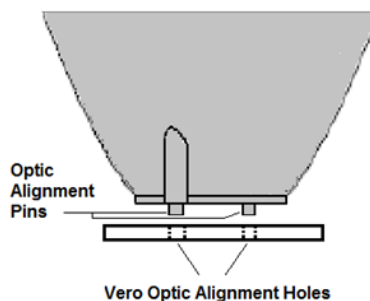

Figure 15: Mechanical attachment of an optic (or optic holder) using pins with tight fit through the two alignment holes on the Vero 13 or 18 Array

Mechanical Clearance Features

When designing or selecting an optic for Bridgelux Vero Arrays ensure that the physical dimensions of the optic or optic holder allow clearance for mounting screw heads and solder joints. Figures 16a and 16b illustrate options for providing additional clearance for the solder pads and mounting screws.



Figure 16a: Recesses on the outer wall of the reflector provide clearance for soldered wires above the Vero Array solder pad



Figure 16b: Recesses on the outer wall of the reflector provide clearance for mounting screws

Size

The physical dimensions of an optic may dramatically impact its performance. For example, larger and taller reflectors may have higher collection efficiencies and may produce patterns of light with more refined features than smaller and shorter reflectors. The size of the luminaire and the size of the Vero Array, including source size, dictate the size of the optic.

Commercially Available Optics for Bridgelux Vero Arrays

Designers have options when it comes to selecting commercially available optics. Many manufacturers produce optics that work well with Bridgelux Vero Arrays to enable rapid system design. Optics available from these manufacturers are too numerous to list here and are constantly being updated. For a current list of commercially available “off-the-shelf” optics which are suitable for use with Bridgelux Vero Arrays, please contact a Bridgelux sales representative or visit our website. You can check directly with the optics supplier for the latest information regarding product specifications and availability. Any optic selected must be thoroughly evaluated to ensure that all application requirements are met.

Custom Optics

Depending on application requirements, designing a custom optic may have advantages for a given lighting system. Table 5 provides a partial list of companies who specialize in the design and manufacturing of custom optics for LED lighting sources. Some of these companies have the capability to both design and manufacture optics, where others offer only design services. Designers with manufacturing capabilities are noted.

Company	Website	Manufacturing Capability
Polymer Optics	www.polymer-optics.co.uk	YES
Carclo	www.carclo-optics.com	YES
Alux Luxar	www.alux-luxar.de	YES
Gaggione	www.lednlight.com	YES
Jordan Reflektoren	www.jordan-reflektoren.de	YES
DBM Reflex	www.dbmreflex.com	YES
LTI	www.ltioptics.com	NO
Song Yih	www.songyih.biz	YES
Almecco	www.almecogroup.com	YES
Arcco	www.arccoinc.com	YES
Ledil	www.ledil.fi	YES
LPI	www.lpi-llc.com	NO
Nata	www.nata.cn	YES
Widegerm	www.widegerm.com.hk	YES
WhiteOptics	ww.whiteoptics.com	YES
OptoSource	www.opto-source.net	YES
Aether Systems	www.aether-systems.com	YES
ACL Reflektoren	www.reflektor.de	YES
Khatod	www.khatod.com	YES
Fraen	www.fraen.com	YES
Bicom Optics	www.biocomoptics.com	YES
Enplas Corp	http://www.enplas.co.jp	YES

Table 5: Partial list of companies specializing in custom optics design and manufacturing

Design Resources

Photopics Overview

www.konicaminolta.ro/measuring-instruments/color-light-knowledge/the-language-of-light/2concepts/23-photometry/23-photometry-2.html#c18336

General Light Theory

www.hyperphysics.phy-astr.gsu.edu/hbase/hph.html

Joseph W. Goodman, *Introduction to Fourier Optics*, McGraw-Hill, 1996

Disclaimer

This applications note has been prepared to provide guidance on the application of Bridgelux Vero Arrays in customer applications. Bridgelux provides this information in good faith, but does not assume any responsibility or liability for design deficiencies that might exist in a customer design.

BRIDGELUX MAKES NO REPRESENTATION OR WARRANTY WITH RESPECT TO THE ACCURACY, APPLICABILITY, FITNESS, OR COMPLETENESS OF THE CONTENTS OF THIS APPLICATIONS NOTE. BRIDGELUX DISCLAIMS ANY WARRANTIES (EXPRESS OR IMPLIED), MERCHANTABILITY, OR FITNESS FOR ANY PARTICULAR PURPOSE. BRIDGELUX SHALL IN NO EVENT BE HELD LIABLE TO ANY PARTY FOR ANY DIRECT, INDIRECT, PUNITIVE, SPECIAL, INCIDENTAL OR OTHER CONSEQUENTIAL DAMAGES ARISING DIRECTLY OR INDIRECTLY FROM ANY USE OF THIS TECHNICAL REPORT, WHICH IS PROVIDED "AS IS."

It is the responsibility of the customer to ensure that the design meets all necessary requirements and safety certifications for its intended use.

About Bridgelux

Bridgelux is a leading developer and manufacturer of technologies and solutions transforming the \$40 billion global lighting industry into a \$100 billion market opportunity. Based in Livermore, California, Bridgelux is a pioneer in solid state lighting (SSL), expanding the market for light emitting diode (LED) technologies by driving down the cost of LED lighting systems. Bridgelux's patented light source technology replaces traditional technologies (such as incandescent, halogen, fluorescent and high intensity discharge lighting) with integrated, solid state lighting solutions that enable lamp and luminaire manufacturers to provide high performance and energy efficient white light for the rapidly growing interior and exterior lighting markets, including street lights, commercial lighting and consumer applications. With more than 550 patent applications filed or granted worldwide, Bridgelux is the only vertically integrated LED manufacturer and developer of solid state light sources that designs its solutions specifically for the lighting industry.

For more information about the company, please visit www.bridgelux.com



© 2013 Bridgelux, Inc. All rights reserved. Product specifications are subject to change without notice