

# Bridgelux® SMD 2835 1W 9V Gen 2

Product Data Sheet DS58

# Introduction

SMD 2835



The Bridgelux SMD 2835 low power LED is hot-color targeted, which ensures that the LEDs fall within their specified color bin at the typical application conditions of 85°C. With its broad lumen coverage and wide range of CCT options, the SMD 2835 provides unparalleled design-in flexibility for indoor and outdoor lighting applications. The SMD 2835 is ideal as a drop-in replacement for emitters with an industry standard 2.8mm x 3.5mm footprint.

## Features

- Industry-standard 2835 footprint
- 9 bin color control enables tight color control
- Hot-color targeting ensures that color is within the ANSI bin at the typical application conditions of 85°C
- Enables 3- and 5-step MacAdam ellipse custom binning kits
- RoHS compliant and lead free
- Multiple CCT configurations for a wide range of lighting applications

## Benefits

- Lower operating and manufacturing cost
- Ease of design and rapid go-to-market
- Uniform consistent white light
- Reliable and constant white point
- Environmentally friendly, complies with standards
- Design flexibility

# Contents

Product Feature Map	2
Product Nomenclature	2
Product Test Conditions	2
Product Selection Guide	3
Performance at Commonly Used Drive Currents	4
Electrical Characteristics	6
Absolute Maximum Ratings	7
Product Bin Definitions	8
Performance Curves	11
Typical Radiation Pattern	14
Typical Color Spectrum	15
Mechanical Dimensions	16
Reliability	17
Reflowing Characteristics	18
Packaging	19
Design Resources	21
Precautions	21
Disclaimers	21
About Bridgelux	22

# Product Feature Map

Bridgelux SMD LED products come in industry standard package sizes and follow ANSI binning standards. These LEDs are optimized for cost and performance, helping to ensure highly competitive system lumen per dollar performance while addressing the stringent efficacy and reliability standards required for modern lighting applications.

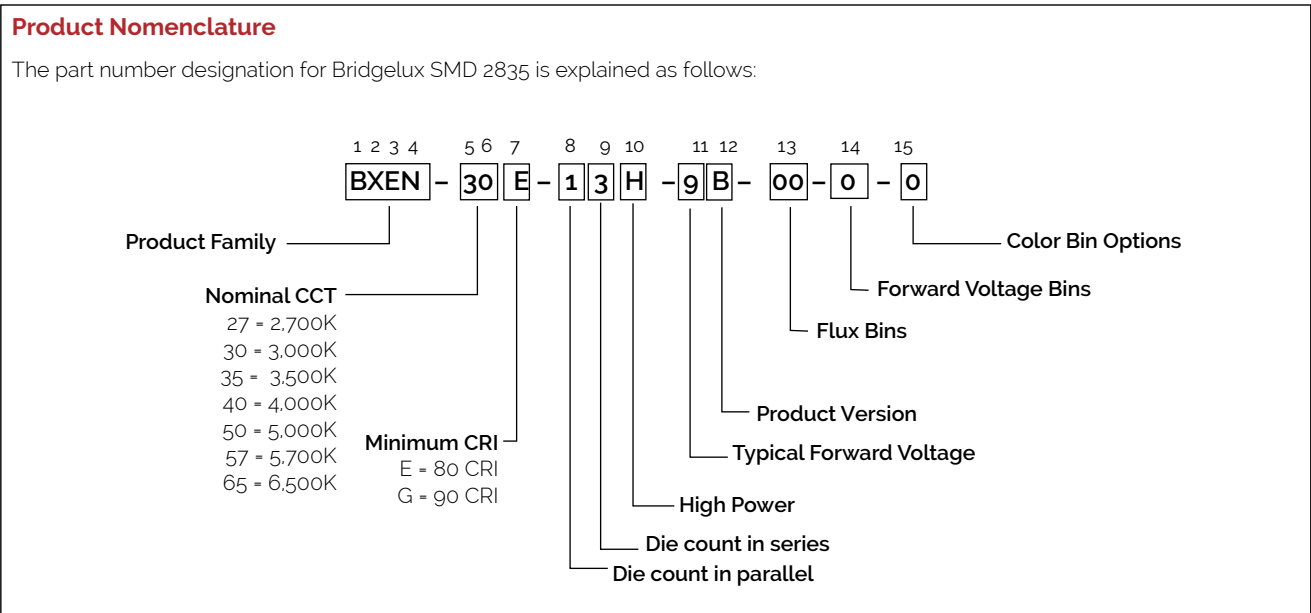
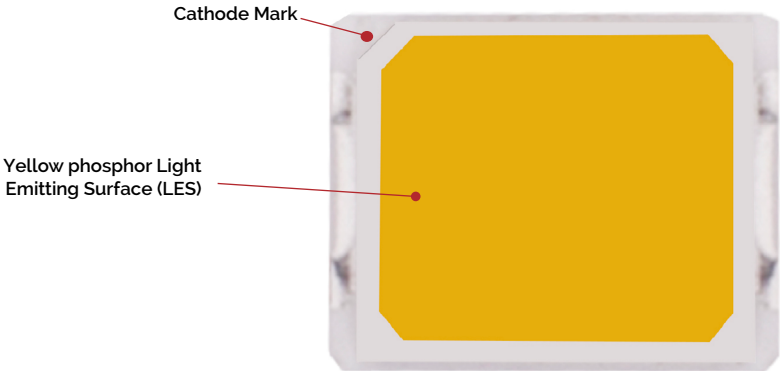

**Product Test Conditions**

Bridgelux SMD 2835 LEDs are tested and binned with a 10ms pulse of 100mA at  $T_j$  (junction temperature) =  $T_{sp}$  (solder point temperature) = 25°C. Forward voltage and luminous flux are binned at a  $T_j = T_{sp} = 25^\circ\text{C}$ , while color is hot targeted at a  $T_{sp}$  of 85°C.

# Product Selection Guide

The following product configurations are available:

**Table 1:** Selection Guide, Pulsed Measurement Data at 100mA ( $T_j = T_{sp} = 25^\circ\text{C}$ )

Part Number <sup>1,6</sup>	Nominal CCT <sup>2</sup> (K)	CRI <sup>3,5</sup>	Nominal Drive Current (mA)	Forward Voltage <sup>4,5</sup> (V)			Typical Pulsed Flux (lm) <sup>4,5</sup>	Typical Power (W)	Typical Efficacy (lm/W)
				Min	Typical	Max			
BXEN-27E-13H-9B-00-0-0	2700	80	100	8.8	9.5	9.6	115	1.0	121
BXEN-27G-13H-9B-00-0-0	2700	90	100	8.8	9.5	9.6	100	1.0	105
BXEN-30E-13H-9B-00-0-0	3000	80	100	8.8	9.5	9.6	120	1.0	126
BXEN-30G-13H-9B-00-0-0	3000	90	100	8.8	9.5	9.6	100	1.0	105
BXEN-35E-13H-9B-00-0-0	3500	80	100	8.8	9.5	9.6	123	1.0	129
BXEN-35G-13H-9B-00-0-0	3500	90	100	8.8	9.5	9.6	102	1.0	107
BXEN-40E-13H-9B-00-0-0	4000	80	100	8.8	9.5	9.6	127	1.0	134
BXEN-40G-13H-9B-00-0-0	4000	90	100	8.8	9.5	9.6	105	1.0	111
BXEN-50E-13H-9B-00-0-0	5000	80	100	8.8	9.5	9.6	127	1.0	134
BXEN-50G-13H-9B-00-0-0	5000	90	100	8.8	9.5	9.6	105	1.0	111
BXEN-57E-13H-9B-00-0-0	5700	80	100	8.8	9.5	9.6	127	1.0	134
BXEN-57G-13H-9B-00-0-0	5700	90	100	8.8	9.5	9.6	105	1.0	111
BXEN-65E-13H-9B-00-0-0	6500	80	100	8.8	9.5	9.6	125	1.0	132

**Table 2:** Selection Guide, Stabilized DC Performance ( $T_{sp} = 85^\circ\text{C}$ )<sup>7,8</sup>

Part Number <sup>1,6</sup>	Nominal CCT <sup>2</sup> (K)	CRI <sup>3,5</sup>	Nominal Drive Current (mA)	Forward Voltage <sup>5</sup> (V)			Typical DC Flux (lm) <sup>4,5</sup>	Typical Power (W)	Typical Efficacy (lm/W)
				Min	Typical	Max			
BXEN-27E-13H-9B-00-0-0	2700	80	100	8.5	9.2	9.3	101	0.9	110
BXEN-27G-13H-9B-00-0-0	2700	90	100	8.5	9.2	9.3	88	0.9	96
BXEN-30E-13H-9B-00-0-0	3000	80	100	8.5	9.2	9.3	106	0.9	115
BXEN-30G-13H-9B-00-0-0	3000	90	100	8.5	9.2	9.3	88	0.9	96
BXEN-35E-13H-9B-00-0-0	3500	80	100	8.5	9.2	9.3	108	0.9	118
BXEN-35G-13H-9B-00-0-0	3500	90	100	8.5	9.2	9.3	90	0.9	98
BXEN-40E-13H-9B-00-0-0	4000	80	100	8.5	9.2	9.3	112	0.9	122
BXEN-40G-13H-9B-00-0-0	4000	90	100	8.5	9.2	9.3	92	0.9	101
BXEN-50E-13H-9B-00-0-0	5000	80	100	8.5	9.2	9.3	112	0.9	122
BXEN-50G-13H-9B-00-0-0	5000	90	100	8.5	9.2	9.3	92	0.9	101
BXEN-57E-13H-9B-00-0-0	5700	80	100	8.5	9.2	9.3	112	0.9	122
BXEN-57G-13H-9B-00-0-0	5700	90	100	8.5	9.2	9.3	92	0.9	101
BXEN-65E-13H-9B-00-0-0	6500	80	100	8.5	9.2	9.3	110	0.9	120

Notes for Table 1 & 2:

- The last 6 characters (including hyphens '-') refer to flux bins, forward voltage bins, and color bin options, respectively. "00-0-0" denotes the full distribution of flux, forward voltage, and 7 SDCM color.  
Example: BXEN-30E-13H-9B-00-0-0 refers to the full distribution of flux, forward voltage, and color within a 3000K 7-step ANSI standard chromaticity region with a minimum of 80CRI, 1x3 die configuration, high power, 9.5V typical forward voltage at  $T_{sp} = 25^\circ\text{C}$
- Product CCT is hot targeted at  $T_{sp} = 85^\circ\text{C}$ . Nominal CCT as defined by ANSI C78.377-2011.
- Listed CRIs are minimum values and include test tolerance.
- Products tested under pulsed condition (10ms pulse width) at nominal drive current where  $T_j - T_{sp} = 25^\circ\text{C}$ .
- Bridgelux maintains a  $\pm 7.5\%$  tolerance on luminous flux measurements,  $\pm 0.1\text{V}$  tolerance on forward voltage measurements, and  $\pm 2$  tolerance on CRI measurements for the SMD 2835.
- Refer to Table 6 and Table 7 for Bridgelux SMD 2835 Luminous Flux Binning and Forward Voltage Binning information.
- Typical DC (direct current) test performance values are provided as reference only and are not a guarantee of performance.
- Typical performance is estimated based on operation under DC current with LED emitter mounted onto a heat sink with thermal interface material and the solder point temperature maintained at  $85^\circ\text{C}$ . Based on Bridgelux test setup, values may vary depending on the thermal design of the luminaire and/or the exposed environment to which the product is subjected.

# Performance at Commonly Used Drive Currents

SMD 2835 LEDs are tested to the specifications shown using the nominal drive currents in Table 1. SMD 2835 may also be driven at other drive currents dependent on specific application design requirements. The performance at any drive current can be derived from the current vs. voltage characteristics shown in Figure 2 and the relative luminous flux vs. current characteristics shown in Figure 3. The performance at commonly used drive currents is summarized in Table 3.

**Table 3:** Performance at Commonly Used Drive Currents

Part Number	CRI	Drive Current <sup>1</sup> (mA)	Typical $V_f$ $T_{sp} = 25^\circ\text{C}$ (V)	Typical Power $T_{sp} = 25^\circ\text{C}$ (W)	Typical Pulsed Flux <sup>2</sup> $T_{sp} = 25^\circ\text{C}$ (lm)	Typical DC Flux <sup>3</sup> $T_{sp} = 85^\circ\text{C}$ (lm)	Typical Efficacy $T_{sp} = 25^\circ\text{C}$ (lm/W)
BXEN-27E-13H-9B-00-0-0	80	30	8.2	0.2	41	36	165
		60	8.8	0.5	75	65	142
		80	9.2	0.7	96	82	131
		<b>100</b>	<b>9.5</b>	<b>1.0</b>	<b>115</b>	<b>101</b>	<b>121</b>
		120	9.8	1.2	132	111	113
BXEN-27G-13H-9B-00-0-0	90	30	8.2	0.2	35	31	144
		60	8.8	0.5	65	57	124
		80	9.2	0.7	83	71	114
		<b>100</b>	<b>9.5</b>	<b>1.0</b>	<b>100</b>	<b>88</b>	<b>105</b>
		120	9.8	1.2	115	96	98
BXEN-30E-13H-9B-00-0-0	80	30	8.2	0.2	42	37	172
		60	8.8	0.5	79	68	149
		80	9.2	0.7	100	86	136
		<b>100</b>	<b>9.5</b>	<b>1.0</b>	<b>120</b>	<b>106</b>	<b>126</b>
		120	9.8	1.2	138	116	117
BXEN-30G-13H-9B-00-0-0	90	30	8.2	0.2	35	31	144
		60	8.8	0.5	65	57	124
		80	9.2	0.7	83	71	114
		<b>100</b>	<b>9.5</b>	<b>1.0</b>	<b>100</b>	<b>88</b>	<b>105</b>
		120	9.8	1.2	115	96	98
BXEN-35E-13H-9B-00-0-0	80	30	8.2	0.2	43	38	177
		60	8.8	0.5	80	70	152
		80	9.2	0.7	103	88	140
		<b>100</b>	<b>9.5</b>	<b>1.0</b>	<b>123</b>	<b>108</b>	<b>129</b>
		120	9.8	1.2	142	118	120
BXEN-35G-13H-9B-00-0-0	90	30	8.2	0.2	36	32	146
		60	8.8	0.5	67	58	126
		80	9.2	0.7	85	73	116
		<b>100</b>	<b>9.5</b>	<b>1.0</b>	<b>102</b>	<b>90</b>	<b>107</b>
		120	9.8	1.2	118	98	100
BXEN-40E-13H-9B-00-0-0	80	30	8.2	0.2	45	39	182
		60	8.8	0.5	83	72	157
		80	9.2	0.7	106	91	144
		<b>100</b>	<b>9.5</b>	<b>1.0</b>	<b>127</b>	<b>112</b>	<b>134</b>
		120	9.8	1.2	146	122	124

Notes for Table 3:

1. Alternate drive currents in Table 3 are provided for reference only and are not a guarantee of performance.
2. Bridgelux maintains a  $\pm 7.5\%$  tolerance on flux measurements.
3. Typical stabilized DC performance values are provided as reference only and are not a guarantee of performance.

# Performance at Commonly Used Drive Currents

**Table 3:** Performance at Commonly Used Drive Currents (Continued)

Part Number	CRI	Drive Current <sup>1</sup> (mA)	Typical $V_f$ $T_{sp} = 25^\circ\text{C}$ (V)	Typical Power $T_{sp} = 25^\circ\text{C}$ (W)	Typical Pulsed Flux <sup>2</sup> $T_{sp} = 25^\circ\text{C}$ (lm)	Typical DC Flux <sup>3</sup> $T_{sp} = 85^\circ\text{C}$ (lm)	Typical Efficacy $T_{sp} = 25^\circ\text{C}$ (lm/W)
BXEN-40G-13H-9B-00-0-0	90	30	8.2	0.2	37	33	151
		60	8.8	0.5	69	59	130
		80	9.2	0.7	88	75	119
		<b>100</b>	<b>9.5</b>	<b>1.0</b>	<b>105</b>	<b>92</b>	<b>111</b>
		120	9.8	1.2	121	101	103
BXEN-50E-13H-9B-00-0-0	80	30	8.2	0.2	45	39	182
		60	8.8	0.5	83	72	157
		80	9.2	0.7	106	91	144
		<b>100</b>	<b>9.5</b>	<b>1.0</b>	<b>127</b>	<b>112</b>	<b>134</b>
		120	9.8	1.2	146	122	124
BXEN-50G-13H-9B-00-0-0	90	30	8.2	0.2	37	33	151
		60	8.8	0.5	69	59	130
		80	9.2	0.7	88	75	119
		<b>100</b>	<b>9.5</b>	<b>1.0</b>	<b>105</b>	<b>92</b>	<b>111</b>
		120	9.8	1.2	121	101	103
BXEN-57E-13H-9B-00-0-0	80	30	8.2	0.2	45	39	182
		60	8.8	0.5	83	72	157
		80	9.2	0.7	106	91	144
		<b>100</b>	<b>9.5</b>	<b>1.0</b>	<b>127</b>	<b>112</b>	<b>134</b>
		120	9.8	1.2	146	122	124
BXEN-57G-13H-9B-00-0-0	90	30	8.2	0.2	37	33	151
		60	8.8	0.5	69	59	130
		80	9.2	0.7	88	75	119
		<b>100</b>	<b>9.5</b>	<b>1.0</b>	<b>105</b>	<b>92</b>	<b>111</b>
		120	9.8	1.2	121	101	103
BXEN-65E-13H-9B-00-0-0	80	30	8.2	0.2	44	39	179
		60	8.8	0.5	82	71	155
		80	9.2	0.7	104	89	142
		<b>100</b>	<b>9.5</b>	<b>1.0</b>	<b>125</b>	<b>110</b>	<b>132</b>
		120	9.8	1.2	144	120	122

Notes for Table 3:

1. Alternate drive currents in Table 3 are provided for reference only and are not a guarantee of performance.
2. Bridgelux maintains a  $\pm 7.5\%$  tolerance on flux measurements.
3. Typical stabilized DC performance values are provided as reference only and are not a guarantee of performance.

# Electrical Characteristics

**Table 4:** Electrical Characteristics

Part Number <sup>1</sup>	Drive Current (mA)	Forward Voltage (V) <sup>2,3</sup>			Typical Temperature Coefficient of Forward Voltage $\Delta V_f / \Delta T$ (mV/°C)	Typical Thermal Resistance Junction to Solder Point <sup>4</sup> $R_{j-sp}$ (°C/W)
		Minimum	Typical	Maximum		
BXEN-xxE-13H-9B-00-0-0	100	8.8	9.5	9.6	-5.18	10

Notes for Table 4:

- The last 6 characters (including hyphens '-') refer to flux bins, forward voltage bins, and color bin options, respectively. "00-0-00" denotes the full distribution of flux, forward voltage, and 7 SDCM color.  
Example: BXEN-30E-13H-9B-00-0-0 refers to the full distribution of flux, forward voltage, and color within a 3000K 7-step ANSI standard chromaticity region with a minimum of 80CRI, 1x3 die configuration, high power, 9.5V typical forward voltage at  $T_{sp} = 25^\circ\text{C}$
- Bridgelux maintains a tolerance of  $\pm 0.1\text{V}$  on forward voltage measurements. Voltage minimum and maximum values at the nominal drive current are guaranteed by 100% test.
- Products tested under pulsed condition (10ms pulse width) at nominal drive current where  $T_{sp} = 25^\circ\text{C}$ .
- Thermal resistance value was calculated using total electrical input power; optical power was not subtracted from input power.



# Absolute Maximum Ratings

**Table 5:** Maximum Ratings

Parameter	Maximum Rating
LED Junction Temperature ( $T_j$ )	125°C
Storage Temperature	-40°C to +100°C
Operating Solder Point Temperature ( $T_{sp}$ )	-40°C to +105°C
Soldering Temperature	260°C or lower for a maximum of 10 seconds
Maximum Drive Current	120mA
Maximum Peak Pulsed Forward Current <sup>1</sup>	240mA
Reverse Voltage	See Note 2
Moisture Sensitivity Rating	MSL 3
Electrostatic Discharge	2kV HBM. JEDEC-JS-001-HBM and JEDEC-JS-001-2012

Notes for Table 5:

1. Bridgelux recommends a maximum duty cycle of 10% and pulse width of 10 ms when operating LED SMD at maximum peak pulsed current specified. Maximum peak pulsed current indicate values where LED SMD can be driven without catastrophic failures.
2. Light emitting diodes are not designed to be driven in reverse voltage and will not produce light under this condition.

# Product Bin Definitions

Table 6 lists the standard photometric luminous flux bins for Bridgelux SMD 2835 LEDs. Although several bins are listed, product availability in a particular bin varies by production run and by product performance. Not all bins are available in all CCTs.

**Table 6:** Luminous Flux Bin Definitions at 100mA,  $T_{sp}=25^{\circ}\text{C}$

Bin Code	Minimum	Maximum	Unit	Condition
5A	90	95	lm	$I_F=100\text{mA}$
5B	95	100		
5C	100	105		
5D	105	110		
5E	110	115		
5F	115	120		
5G	120	125		
5H	125	130		
5J	130	135		
5K	135	140		

Note for Table 6:

1. Bridgelux maintains a tolerance of  $\pm 7.5\%$  on luminous flux measurements.

**Table 7:** Forward Voltage Bin Definition at 100mA,  $T_{sp}=25^{\circ}\text{C}$

Bin Code	Minimum	Maximum	Unit	Condition
S	8.4	8.6	V	$I_F=100\text{mA}$
T	8.6	8.8		
U	8.8	9.0		
V	9.0	9.2		
W	9.2	9.4		
X	9.4	9.6		
Y	9.6	9.8		
Z	9.8	10.0		

Note for Table 7:

1. Bridgelux maintains a tolerance of  $\pm 0.1\text{V}$  on forward voltage measurements.

# Product Bin Definitions

**Table 8:** 3- and 5-step MacAdam Ellipse Color Bin Definitions

CCT	Color Space	Center Point		Major Axis	Minor Axis	Ellipse Rotation Angle	Color Bin
		X	Y				
2700K	3 SDCM	0.4578	0.4101	0.00810	0.00420	53.70	1
	5 SDCM	0.4578	0.4101	0.01350	0.00700	53.70	1/A/B/C/D
3000K	3 SDCM	0.4338	0.4030	0.00834	0.00408	53.22	1
	5 SDCM	0.4338	0.4030	0.01390	0.00680	53.22	1/A/B/C/D
3500K	3 SDCM	0.4073	0.3917	0.00927	0.00414	54.00	1
	5 SDCM	0.4073	0.3917	0.01545	0.00690	54.00	1/A/B/C/D
4000K	3 SDCM	0.3818	0.3797	0.00939	0.00402	53.72	1
	5 SDCM	0.3818	0.3797	0.01565	0.00670	53.72	1/A/B/C/D
5000K	3 SDCM	0.3447	0.3553	0.00822	0.00354	59.62	1
	5 SDCM	0.3447	0.3553	0.01370	0.00590	59.62	1/A/B/C/D
5700K	3 SDCM	0.3287	0.3417	0.00746	0.00320	59.09	1
	5 SDCM	0.3287	0.3417	0.01243	0.00533	59.09	1/A/B/C/D
6500K	3 SDCM	0.3123	0.3282	0.00669	0.00285	58.57	1
	5 SDCM	0.3123	0.3282	0.01115	0.00475	58.57	1/A/B/C/D

Notes for Table 8:

1. Color binning at  $T_{sp} = 85^{\circ}\text{C}$
2. Bridgelux maintains a tolerance of  $\pm 0.007$  on x and y color coordinates in the CIE 1931 color space.

# Product Bin Definitions

Figure 1: C.I.E. 1931 Chromaticity Diagram (g Color Bin Structure, hot-color targeted at  $T_{sp} = 85^{\circ}\text{C}$ )

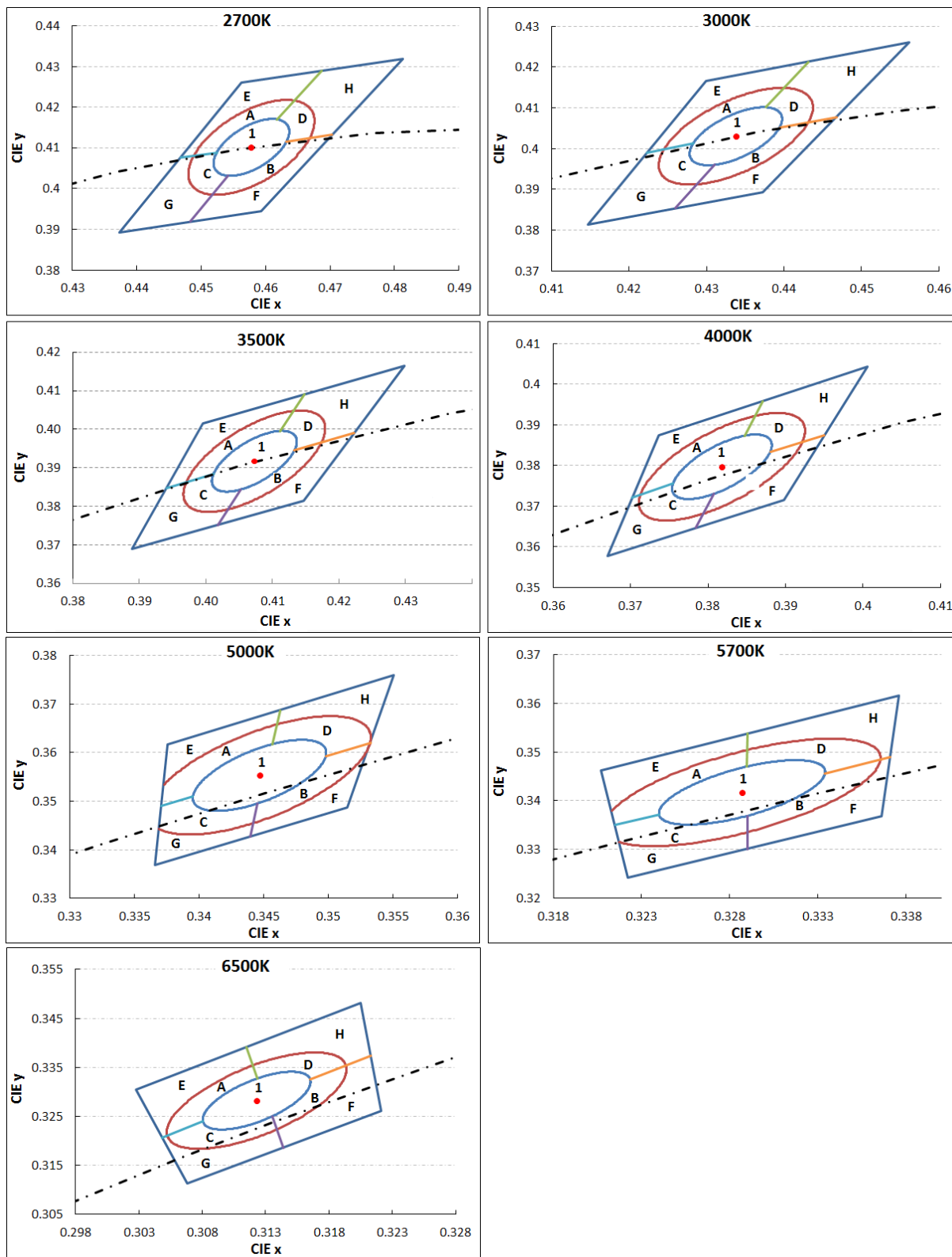

# Performance Curves

**Figure 2: Drive Current vs. Voltage ( $T_{sp}=25^{\circ}\text{C}$ )**

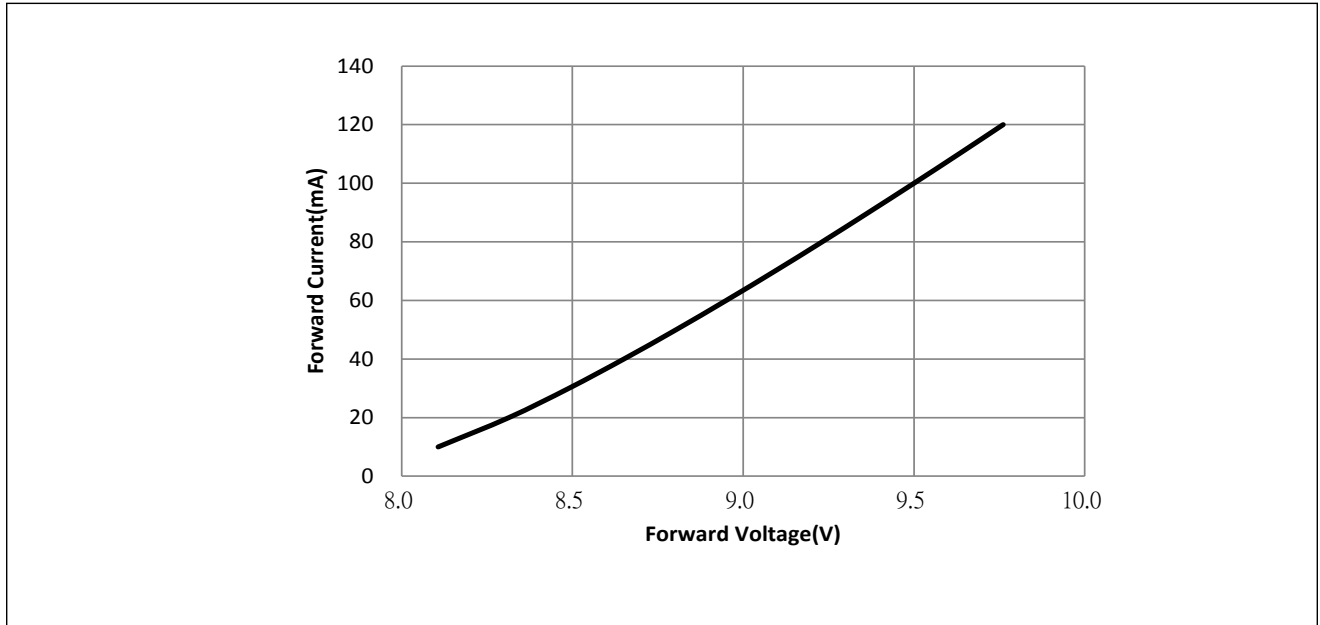

**Figure 3: Typical Relative Luminous Flux vs. Drive Current ( $T_{sp}=25^{\circ}\text{C}$ )**

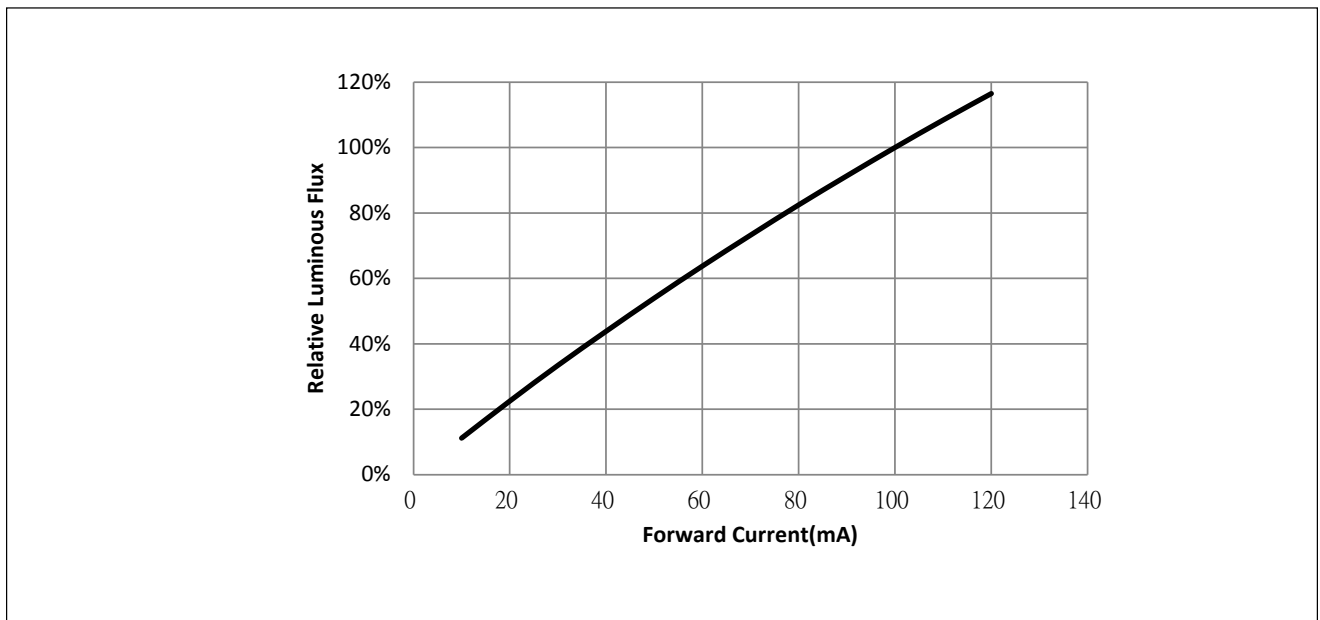

Note for Figure 3:

1. Bridgelux does not recommend driving high power LEDs at low currents. Doing so may produce unpredictable results. Pulse width modulation (PWM) is recommended for dimming effects.

# Performance Curves

**Figure 4: Typical Relative Flux vs. Solder Point Temperature**

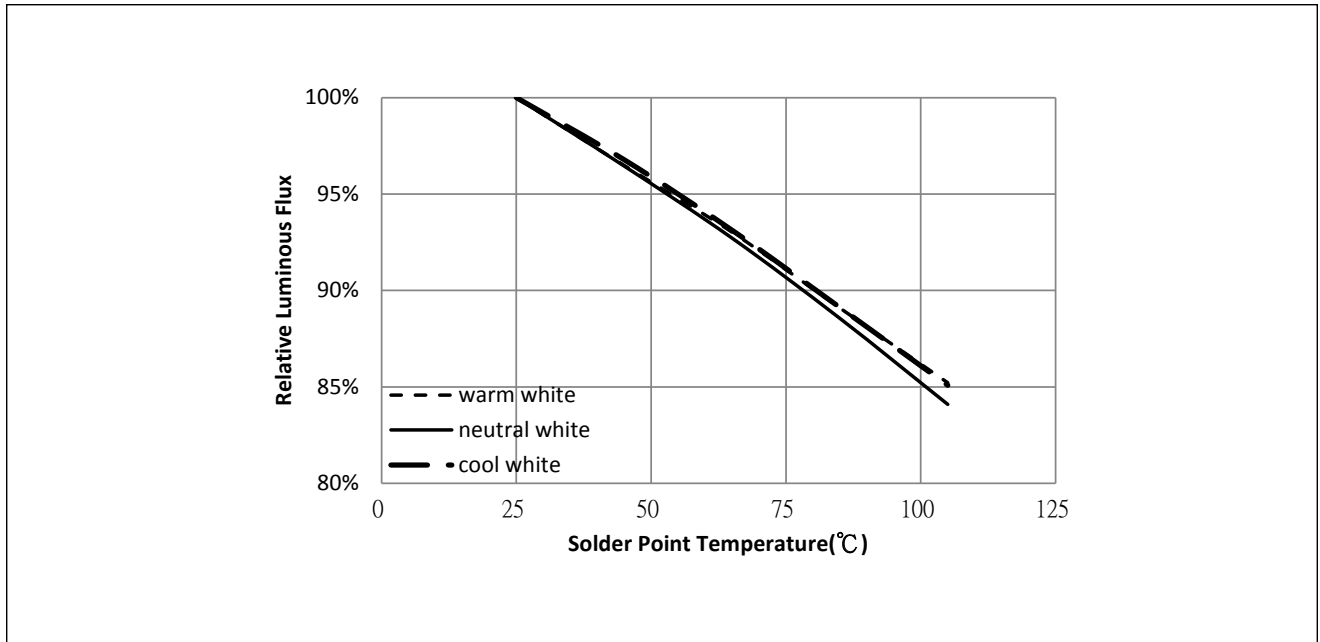

**Figure 5: Typical ccx Shift vs. Solder Point Temperature**

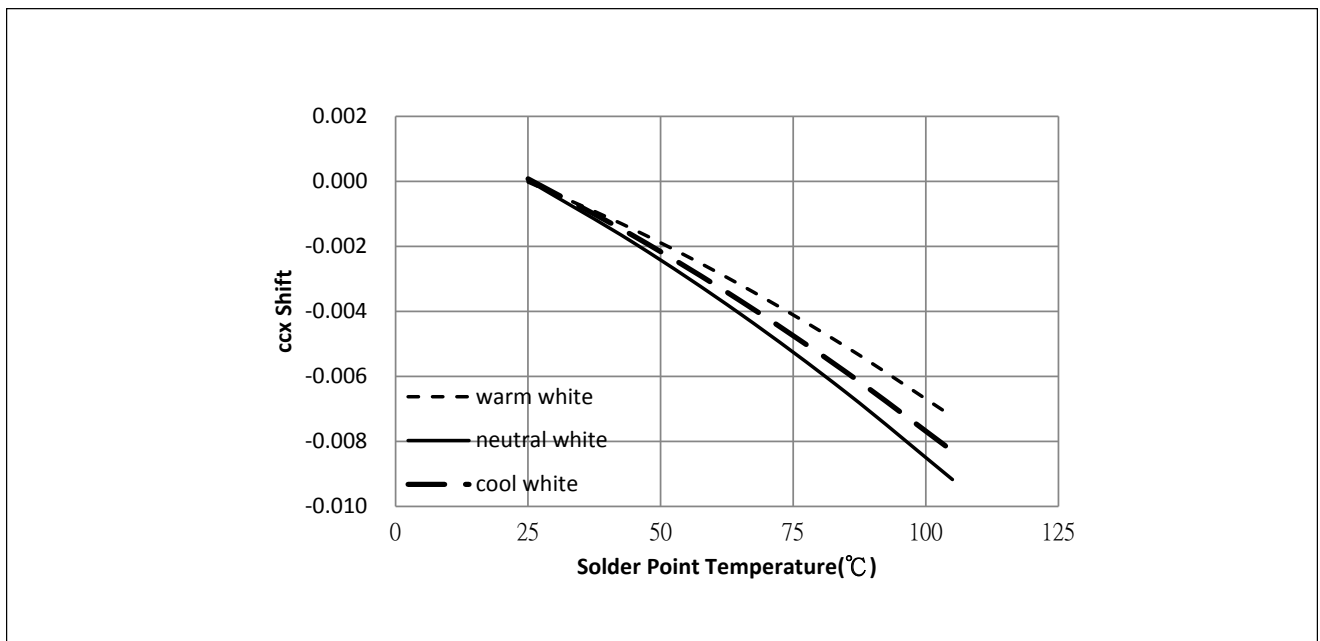

Notes for Figures 4 & 5:

1. Characteristics shown for warm white based on 3000K and 80 CRI.
2. Characteristics shown for neutral white based on 4000K and 80 CRI.
3. Characteristics shown for cool white based on 5000K and 80 CRI.
4. For other color SKUs, the shift in color will vary. Please contact your Bridgelux Sales Representative for more information.

# Performance Curves

**Figure 6: Typical ccy Shift vs.Solder Point Temperature**

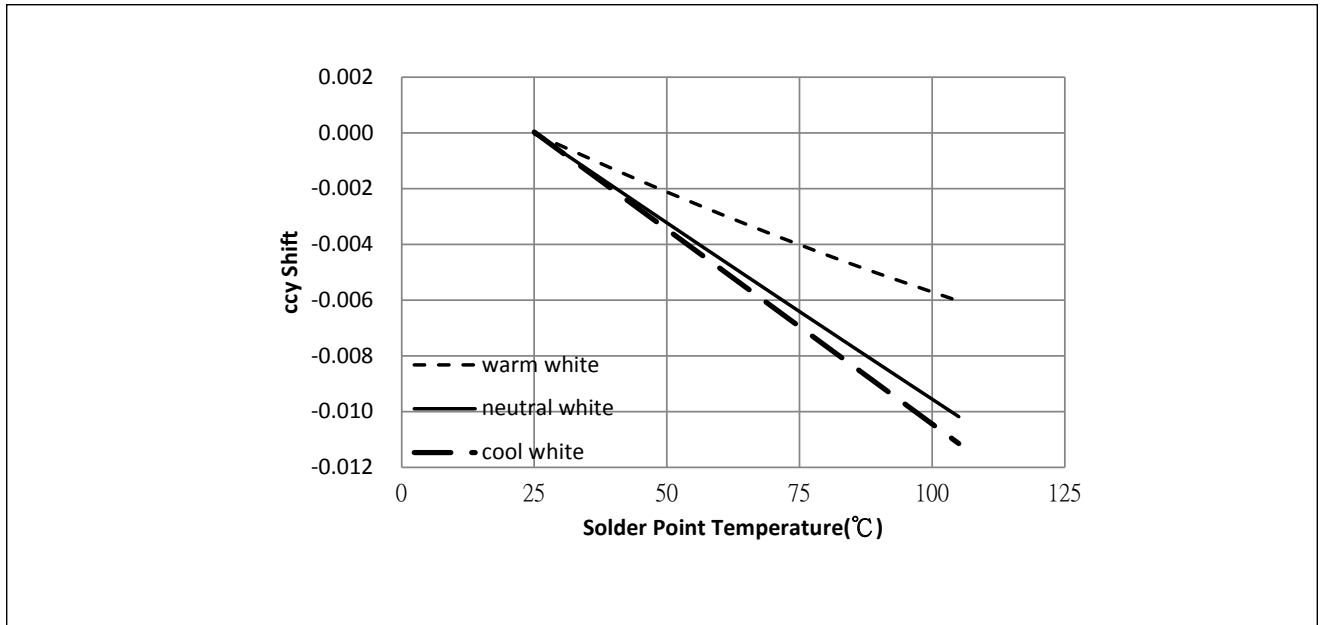

Notes for Figure 6:

1. Characteristics shown for warm white based on 3000K and 80 CRI.
2. Characteristics shown for neutral white based on 4000K and 80 CRI.
3. Characteristics shown for cool white based on 5000K and 80 CRI.
4. For other color SKUs, the shift in color will vary. Please contact your Bridgelux Sales Representative for more information.

# Typical Radiation Pattern

**Figure 7: Typical Spatial Radiation Pattern at 100mA,  $T_{sp} = 25^{\circ}\text{C}$**

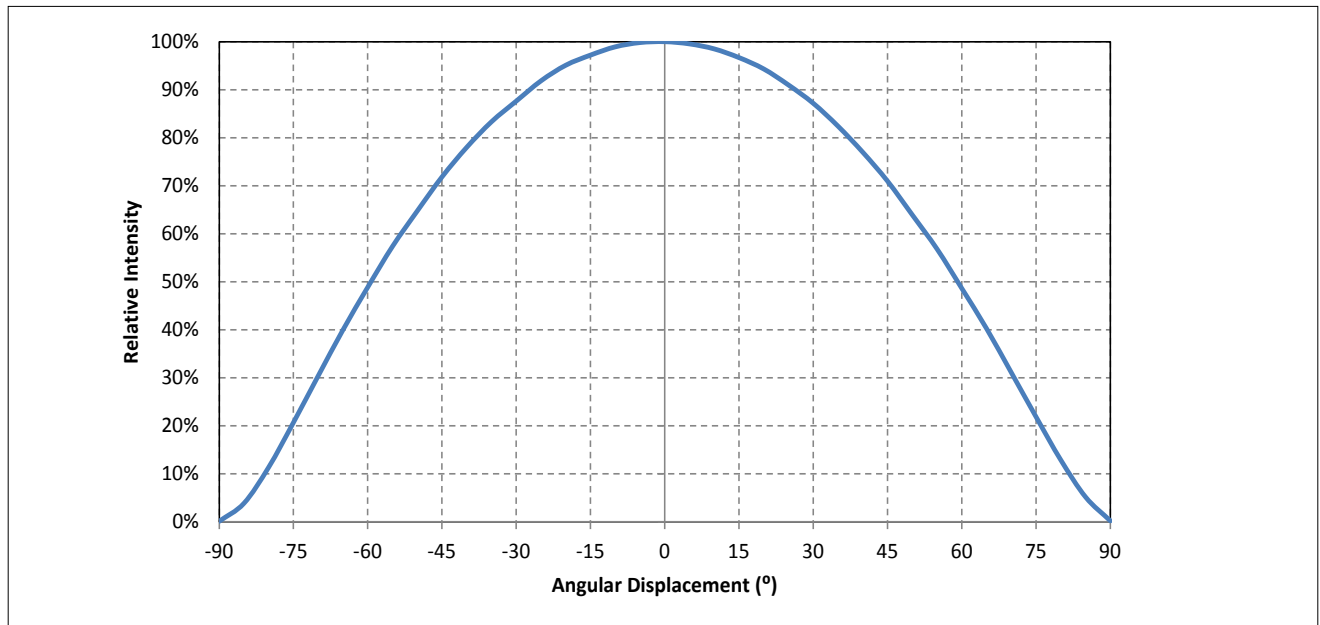

Notes for Figure 7:

1. Typical viewing angle is  $116^{\circ}$ .
2. The viewing angle is defined as the off axis angle from the centerline where luminous intensity (lv) is  $\frac{1}{2}$  of the peak value.

**Figure 8: Typical Polar Radiation Pattern at 100mA,  $T_{sp} = 25^{\circ}\text{C}$**

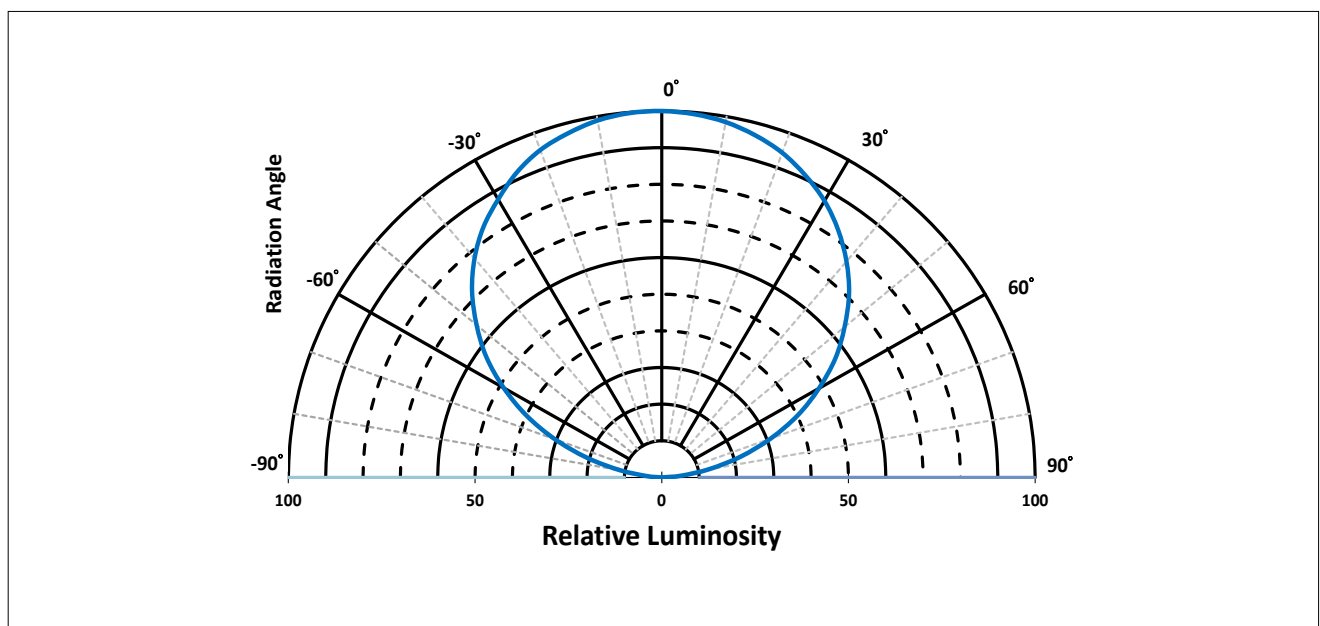



# Typical Color Spectrum

Figure 9: Typical Color Spectrum

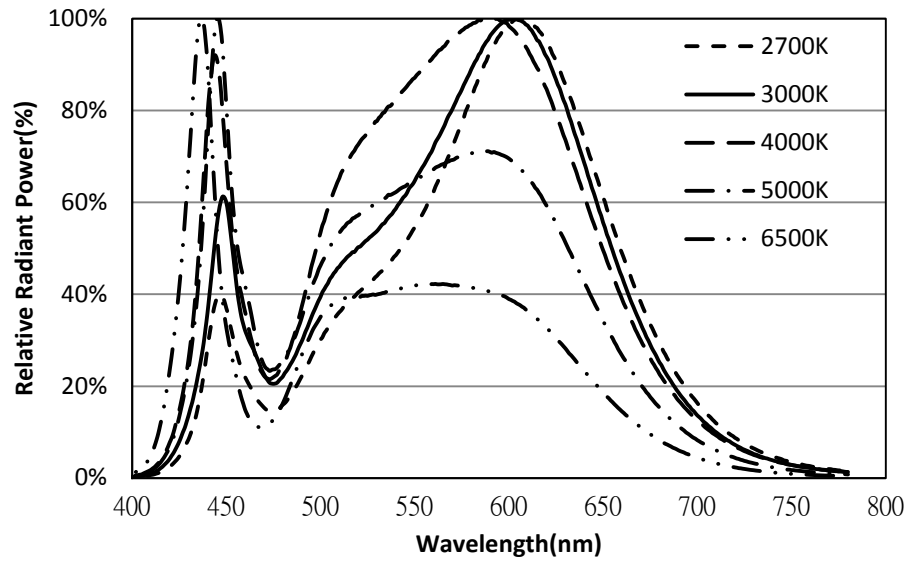

Notes for Figure 9:

1. Color spectra measured at nominal current for  $T_{sp} = 25^{\circ}\text{C}$
2. Color spectra shown for warm white is 2700K and 80 CRI.
3. Color spectra shown for warm white is 3000K and 80 CRI.
4. Color spectra shown for neutral white is 4000K and 80 CRI.
5. Color spectra shown for cool white is 5000K and 80 CRI.
6. Color spectra shown for cool white is 6500K and 80 CRI.

# Mechanical Dimensions

**Figure 10: Drawing for SMD 2835**

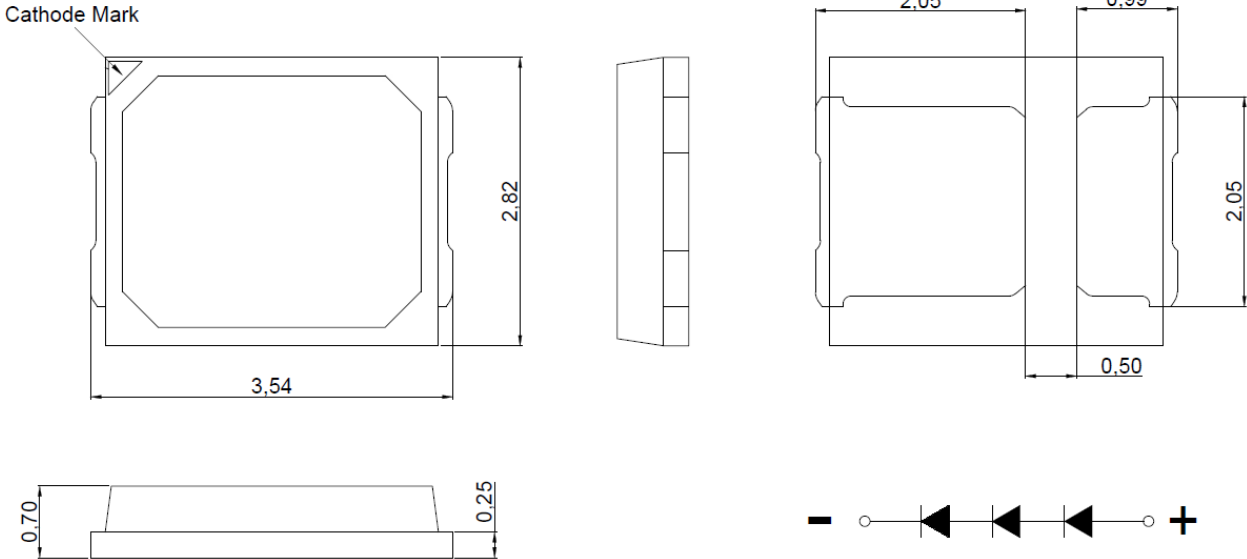

- Notes for Figure 10:
1. Drawings are not to scale.
  2. Drawing dimensions are in millimeters.
  3. Unless otherwise specified, tolerances are  $\pm 0.10\text{mm}$ .

## Recommended PCB Soldering Pad Pattern

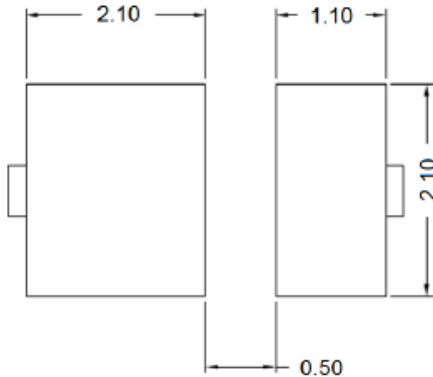

# Reliability

**Table 9: Reliability Test Items and Conditions**

No.	Items	Reference Standard	Test Conditions	Drive Current	Test Duration	Units Failed/Tested
1	Moisture/Reflow Sensitivity	J-STD-020E	$T_{\text{slid}} = 260^{\circ}\text{C}$ , 10sec. Precondition: $60^{\circ}\text{C}$ , 60%RH, 168hr	-	3 reflows	0/22
2	Low Temperature Storage	JESD22-A119	$T_{\text{a}} = -40^{\circ}\text{C}$	-	1000 hours	0/22
3	High Temperature Storage	JESD22-A103D	$T_{\text{a}} = 100^{\circ}\text{C}$	-	1000 hours	0/22
4	Low Temperature Operating Life	JESD22-A108D	$T_{\text{a}} = -40^{\circ}\text{C}$	100mA	1000 hours	0/22
5	Temperature Humidity Operating Life	JESD22-A101C	$T_{\text{sp}} = 85^{\circ}\text{C}$ , RH=85%	100mA	1000 hours	0/22
6	High Temperature Operating Life	JESD22-A108D	$T_{\text{sp}} = 105^{\circ}\text{C}$	120mA	1000 hours	0/22
7	Power switching	IEC62717:2014	$T_{\text{sp}} = 105^{\circ}\text{C}$ 30 sec on, 30 sec off	120mA	30000 cycles	0/22
8	Thermal Shock	JESD22-A106B	$T_{\text{a}} = -40^{\circ}\text{C} \sim 100^{\circ}\text{C}$ ; Dwell: 15min; Transfer: 10sec	-	200 cycles	0/22
9	Temperature Cycle	JESD22-A104E	$T_{\text{a}} = -40^{\circ}\text{C} \sim 100^{\circ}\text{C}$ ; Dwell at extreme temperature: 15min; Ramp rate $< 105^{\circ}\text{C}/\text{min}$	-	200 cycles	0/22
10	Electrostatic Discharge	JS-001-2012	HBM, 2kV, 15k $\Omega$ , 100pF, Alternately positive or negative	-	-	0/22

## Passing Criteria

Item	Symbol	Test Condition	Passing Criteria
Forward Voltage	Vf	100mA	$\Delta V_f < 10\%$
Luminous Flux	Fv	100mA	$\Delta F_v < 30\%$
Chromaticity Coordinates	(x, y)	100mA	$\Delta u'v' < 0.007$

Notes for Table 9:

- Measurements are performed after allowing the LEDs to return to room temperature
- $T_{\text{slid}}$ : reflow soldering temperature;  $T_{\text{a}}$ : ambient temperature

# Reflowing Characteristics

**Figure 11 : Reflow Profile**

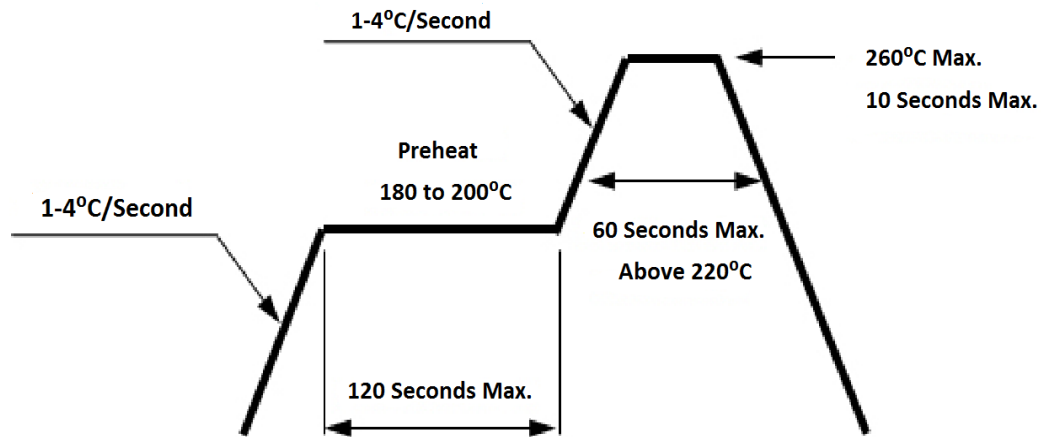

Profile Feature	Lead Free Assembly
Preheat: Temperature Range	180°C – 200°C
Preheat: Time (Maximum)	120 seconds
Peak Temperature	260°C
Soldering Time (Maximum)	10 seconds
Allowable Reflow Cycles	2

**Figure 12 : Pick and Place**

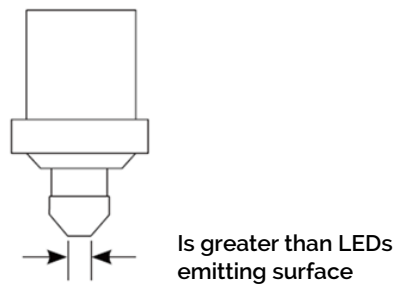

Note for Figure 12:

- When using a pick and place machine, choose a nozzle that has a larger diameter than the LED's emitting surface. Using a Pick-and-Place nozzle with a smaller diameter than the size of the LEDs emitting surface will cause damage and may also cause the LED to not illuminate.

# Packaging

**Figure 13: Emitter Reel Drawings**

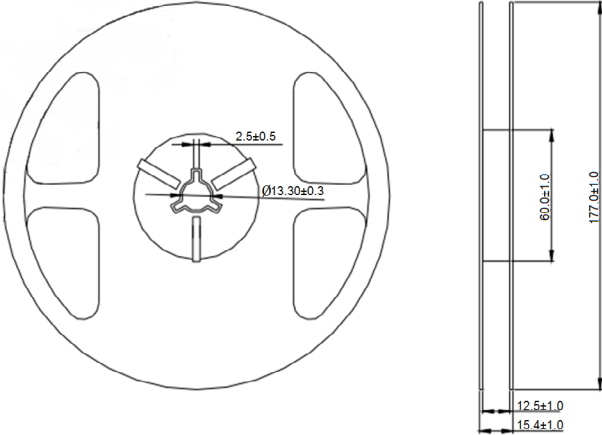

Note for Figure 13:  
 1. Drawings are not to scale. Drawing dimensions are in millimeters.

**Figure 14: Emitter Tape Drawings**

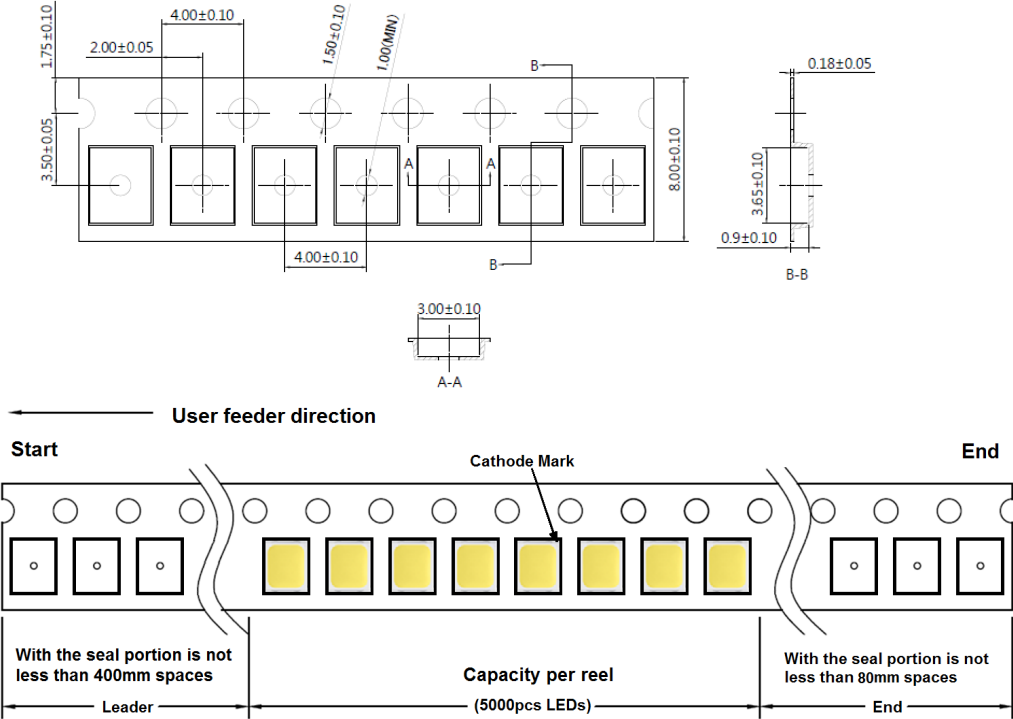

Note for Figure 14:  
 1. Drawings are not to scale. Drawing dimensions are in millimeters.

# Packaging

Figure 15: Emitter Reel Packaging Drawings

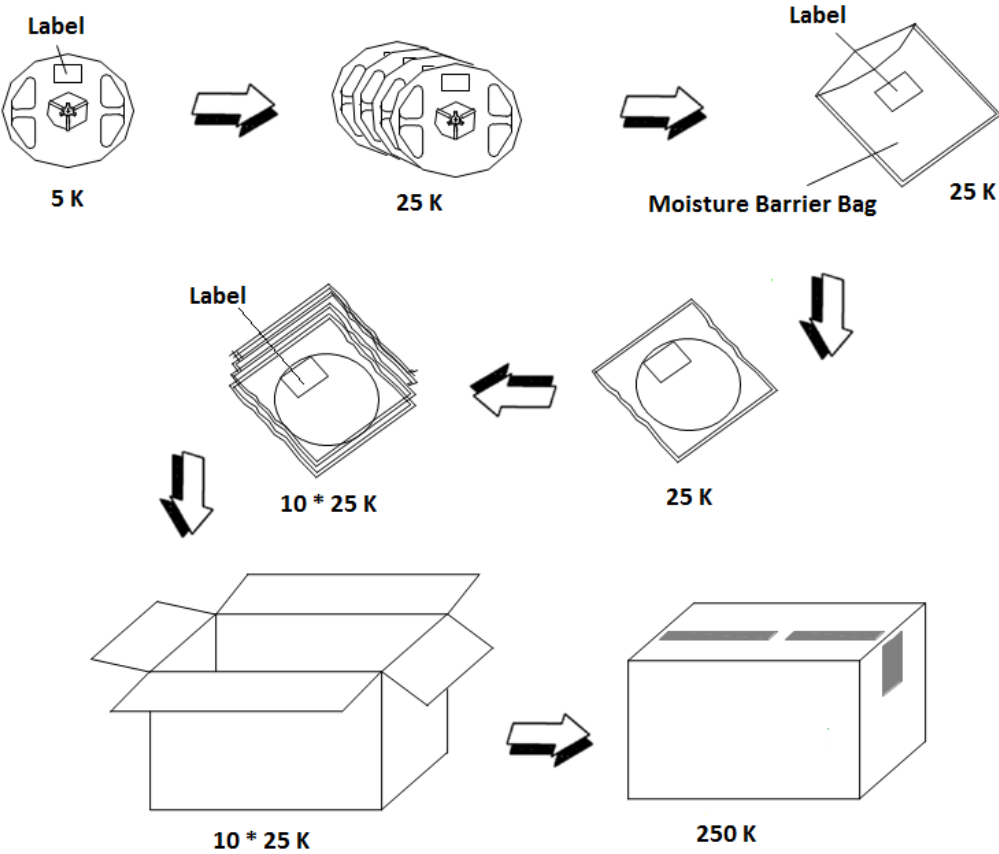

Note for Figure 15:  
1. Drawings are not to scale.

# Design Resources

Please contact your Bridgelux sales representative for assistance.

## Precautions

### **CAUTION: CHEMICAL EXPOSURE HAZARD**

Exposure to some chemicals commonly used in luminaire manufacturing and assembly can cause damage to the LED emitter. Please consult Bridgelux Application Note AN51 for additional information.

### **CAUTION: EYE SAFETY**

Eye safety classification for the use of Bridgelux SMD LED emitter is in accordance with IEC specification EN62471: Photobiological Safety of Lamps and Lamp Systems. SMD LED emitters are classified as Risk Group 1 when operated at or below the maximum drive current. Please use appropriate precautions. It is important that employees working with LEDs are trained to use them safely.

### **CAUTION: RISK OF BURN**

Do not touch the SMD LED emitter during operation. Allow the emitter to cool for a sufficient period of time before handling. The SMD LED emitter may reach elevated temperatures such that could burn skin when touched.

## CAUTION

### **CONTACT WITH LIGHT EMITTING SURFACE (LES)**

Avoid any contact with the LES. Do not touch the LES of the emitter or apply stress to the LES (yellow phosphor resin area). Contact may cause damage to the emitter

Optics and reflectors must not be mounted in contact with the LES (yellow phosphor resin area).

## Disclaimers

### **MINOR PRODUCT CHANGE POLICY**

The rigorous qualification testing on products offered by Bridgelux provides performance assurance. Slight cosmetic changes that do not affect form, fit, or function may occur as Bridgelux continues product optimization.

### **STANDARD TEST CONDITIONS**

Unless otherwise stated, LED emitter testing is performed at the nominal drive current.

# About Bridgelux: We Build Light That Transforms

At Bridgelux, we help companies, industries and people experience the power and possibility of light. Since 2002, we've designed LED solutions that are high performing, energy efficient, cost effective and easy to integrate. Our focus is on light's impact on human behavior, delivering products that create better environments, experiences and returns—both experiential and financial. And our patented technology drives new platforms for commercial and industrial luminaires.

**For more information about the company, please visit**  
**bridgelux.com**  
**twitter.com/Bridgelux**  
**facebook.com/Bridgelux**  
**youtube.com/user/Bridgelux**  
**WeChat ID: BridgeluxInChina**



46430 Fremont Boulevard  
Fremont, CA 94538 USA  
Tel (925) 583-8400  
**www.bridgelux.com**

© 2017 Bridgelux, Inc. All rights reserved 2017. Product specifications are subject to change without notice. Bridgelux and the Bridgelux stylized logo design are registered trademarks of Bridgelux, Inc. All other trademarks are the property of their respective owners.