

Bridgelux® V22 F90 TS Array Series

Product Data Sheet DS1322



Introduction

V Series



The V Series™ LED Array products deliver high quality light in a compact and cost-effective solid-state lighting package. These chip on board (CoB) arrays can be efficiently driven up to two times the nominal drive current, enabling design flexibility not previously possible. These high flux density light sources are designed to support a wide range of high quality, low cost directional luminaires and replacement lamps for both interior and exterior commercial and residential applications.

The F90 V Series COB is a high efficacy product that uses narrow band red phosphor to significantly improve the spectrum efficacy. The improved spectrum efficacy results in the 90 CRI product of the F90 Series delivering better or equivalent efficacy as that of our traditional 80 CRI V Series product.

The V22 LED Array is available in a variety of electrical, CCT, and CRI combinations providing substantial design flexibility and energy efficiency advantages.

Lighting system designs incorporating these LED arrays deliver increased system level efficacy and a longer service life. Typical applications include replacement lamps and task, accent, spot, track, wide area, security, wall packs and down lights.

Features

- Efficacy of 171 lm/W typical, 3000K 90 CRI
- Wide selection of CCT options (2700K-4000K) with minimum 90 CRI options
- Uniform high-quality illumination
- 2 and 3 SDCM binning options (2700K – 4000K)
- Forward voltage bin codes and backside marking
- Instant light with unlimited dimming
- 5-Year warranty

Benefits

- Enables high efficiency lighting systems and lower operating costs
- Supports the trend toward luminaire miniaturization and delivers enhanced optical control
- Design flexibility for a broad range of lighting applications
- Clean white light without pixelation
- Uniform consistent white light
- Design flexibility for multi-source applications
- Easy to use with daylight and motion sensors to increase energy savings
- Design with confidence



Contents

Product Feature Map	2
Product Nomenclature	2
Product Selection Guide	3
European Product Registry for Energy Labeling	5
Performance at Commonly Used Drive Currents	6
Electrical Characteristics	8
Eye Safety	9
Absolute Maximum Ratings	10
Performance Curves	12
Typical Radiation Pattern	14
Typical Color Spectrum	15
Mechanical Dimensions	16
Color Binning Information	17
Packaging and Labeling	18
Design Resources	20
Precautions	20
Disclaimers	20
About Bridgelux	21

Product Feature Map

Bridgelux arrays are fully engineered devices that provide consistent thermal and optical performance on an engineered mechanical platform. The V Series arrays are the most compact CoB devices across all of Bridgelux's LED Array products.

The arrays incorporate several features to simplify design integration and assembly. Please visit www.bridgelux.com for more information on the V Series family of products.

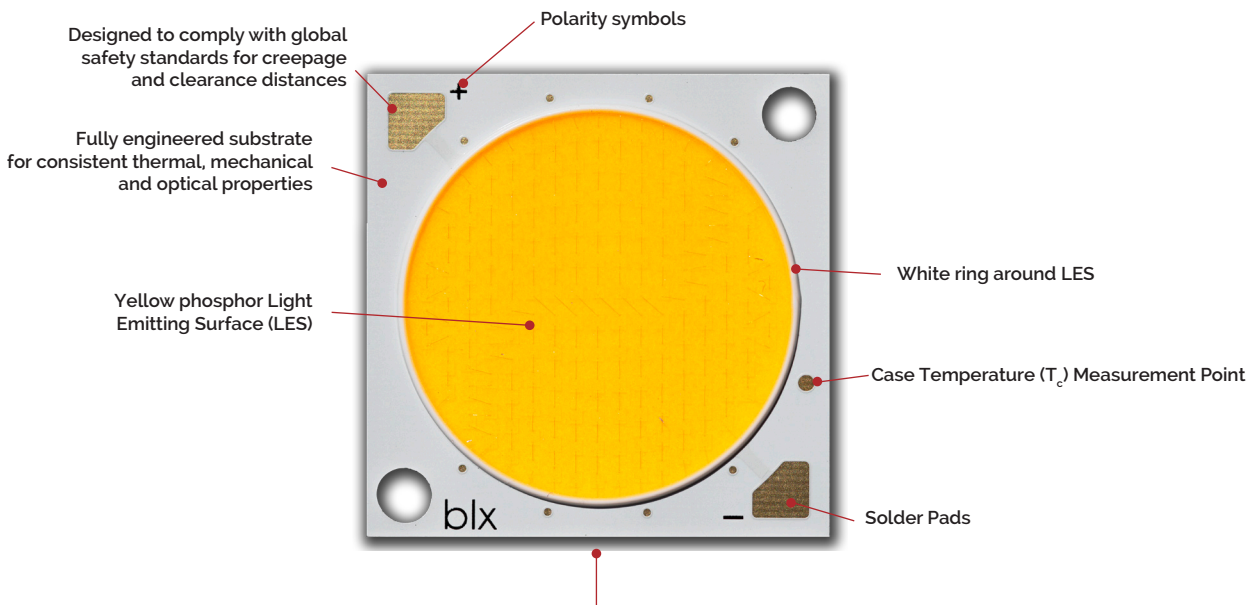

Note: Part number and lot codes are scribed on back of array

Product Nomenclature

The part number designation for Bridgelux V Series LED arrays is explained as follows:

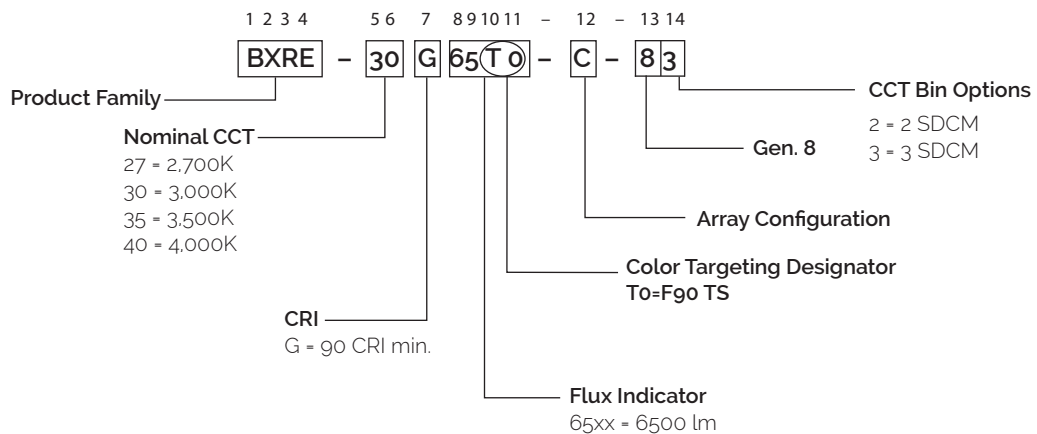

Product Selection Guide

The following product configurations are available:

Table 1: Selection Guide, Pulsed Measurement Data ($T_j = T_c = 25^\circ\text{C}$)

Part Number	Nominal CCT ¹ (K)	CRI ²	Nominal Drive Current ³ (mA)	Typical Pulsed Flux ^{4,5,6} $T_c = 25^\circ\text{C}$ (lm)	Minimum Pulsed Flux ^{6,7} $T_c = 25^\circ\text{C}$ (lm)	Typical V_f (V)	Typical Power (W)	Typical Efficacy (lm/W)
BXRE-27G65To-B-8x	2700	90	950	8050	7245	51.6	49.0	164
BXRE-27G65To-C-8x	2700	90	1200	10150	9135	52.0	62.4	163
BXRE-27G65To-D-8x	2700	90	1050	5950	5355	34.5	36.2	164
BXRE-30G65To-B-8x	3000	90	950	8350	7515	51.6	49.0	170
BXRE-30G65To-C-8x	3000	90	1200	10500	9450	52.0	62.4	168
BXRE-30G65To-D-8x	3000	90	1050	6200	5580	34.5	36.2	171
BXRE-35G65To-B-8x	3500	90	950	8430	7587	51.6	49.0	172
BXRE-35G65To-C-8x	3500	90	1200	10600	9540	52.0	62.4	170
BXRE-35G65To-D-8x	3500	90	1050	6250	5625	34.5	36.2	173
BXRE-40G65To-B-8x	4000	90	950	8650	7785	51.6	49.0	176
BXRE-40G65To-C-8x	4000	90	1200	10850	9765	52.0	62.4	174
BXRE-40G65To-D-8x	4000	90	1050	6400	5760	34.5	36.2	177

Notes for Table 1:

- Nominal CCT as defined by ANSI C78.377-2011.
- CRI values are minimums and tested at $T_j = T_c = 85^\circ\text{C}$. Minimum R_g value for 90 CRI products is 50. Bridgelux maintains a ± 3 tolerance on CRI and R_g values.
- Drive current is referred to as nominal drive current.
- Products tested under pulsed condition (10ms pulse width) at nominal drive current where T_j (junction temperature) - T_c (case temperature) = 25°C .
- Typical performance values are provided as a reference only and are not a guarantee of performance.
- Bridgelux maintains a $\pm 7\%$ tolerance on flux measurements.
- Minimum flux values at the nominal drive current are guaranteed by 100% test.

Product Selection Guide

Table 2: Selection Guide, Stabilized DC Performance ($T_c = 85^\circ\text{C}$)^{4,5}

Part Number	Nominal CCT ¹ (K)	CRI ²	Nominal Drive Current ³ (mA)	Typical DC Flux ^{4,5} $T_c = 85^\circ\text{C}$ (lm)	Minimum DC Flux ⁶ $T_c = 85^\circ\text{C}$ (lm)	Typical V_f (V)	Typical Power (W)	Typical Efficacy (lm/W)
BXRE-27G65To-B-8x	2700	90	950	7406	6665	50.4	479	155
BXRE-27G65To-C-8x	2700	90	1200	9338	8404	50.8	61.0	153
BXRE-27G65To-D-8x	2700	90	1050	5474	4927	33.7	35.4	155
BXRE-30G65To-B-8x	3000	90	950	7682	6914	50.4	47.9	160
BXRE-30G65To-C-8x	3000	90	1200	9660	8694	50.8	61.0	158
BXRE-30G65To-D-8x	3000	90	1050	5704	5134	33.7	35.4	161
BXRE-35G65To-B-8x	3500	90	950	7756	6980	50.4	47.9	162
BXRE-35G65To-C-8x	3500	90	1200	9752	8777	50.8	61.0	160
BXRE-35G65To-D-8x	3500	90	1050	5750	5175	33.7	35.4	163
BXRE-40G65To-B-8x	4000	90	950	7958	7162	50.4	47.9	166
BXRE-40G65To-C-8x	4000	90	1200	9982	8984	50.8	61.0	164
BXRE-40G65To-D-8x	4000	90	1050	5888	5299	33.7	35.4	166

Notes for Table 2:

1. Nominal CCT as defined by ANSI C78.377-2011.
2. CRI values are minimums and tested at $T_j = T_c = 85^\circ\text{C}$. Minimum Rg value for 90 CRI products is 50.
3. Drive current is referred to as nominal drive current.
4. Typical stabilized DC performance values are provided as reference only and are not a guarantee of performance.
5. Typical performance is estimated based on operation under DC (direct current) with LED array mounted onto a heat sink with thermal interface material and the case temperature maintained at 85°C . Based on Bridgelux test setup, values may vary depending on the thermal design of the luminaire and/or the exposed environment to which the product is subjected.
6. Minimum flux values at elevated temperatures are provided for reference only and are not guaranteed by 100% production testing. Based on Bridgelux test setup, values may vary depending on the thermal design of the luminaire and/or the exposed environment to which the product is subjected.

European Product Registry for Energy Labeling

The European Product Registry for Energy Labeling (EPREL) is defined in the EU Regulation 2017/1369 to provide important energy efficiency information to consumers. Together with Energy Labeling Regulation ELR (EU) 2019/2015 which was amended by regulation (EU) 2021/340 for energy labelling of light sources, manufacturers are required to declare an energy class based on key technical specifications from each of their product and register it in an open data base managed by EPREL. It is now a legal requirement for a vendor of light sources to upload information about their products into the EPREL database before placing these products on the market in the EU.

Table 3 below provides a list of part numbers that are in compliance with ELR and are currently listed in the EPREL database.

At Bridgelux, we are fully committed to supplying products that are compliant with pertinent laws, rules, and obligation imposed by relevant government bodies including the European Energy Labeling regulation. Customers can use these products with full confidence for any projects that fall under the ELR.

Table 3: Part numbers registered in European Product Registry for Energy Labeling

PART NUMBER ¹	CCT (K)	CRI	Current ² (mA)	Vf (V)	Useful flux ³ (Φ_{use}) at 85C (lm)	Power (W)	Efficacy (lm/W)	Energy efficiency class ⁴ 	Registration No	URL to Product Information Sheet in EPREL Database
BXRE-27G65To-B-83	2700	90	2340	57.0	16491	133	124	E	1848547	https://eprelec.europa.eu/qr/1848547
BXRE-27G65To-C-83	2700	90	2700	57.0	19589	154	127	E	1848548	https://eprelec.europa.eu/qr/1848548
BXRE-27G65To-D-83	2700	90	2520	38.0	12189	96	127	E	1848549	https://eprelec.europa.eu/qr/1848549
BXRE-30G65To-B-83	3000	90	2340	57.0	17105	133	128	E	1848559	https://eprelec.europa.eu/qr/1848559
BXRE-30G65To-C-83	3000	90	2700	57.0	20264	154	132	E	1848560	https://eprelec.europa.eu/qr/1848560
BXRE-30G65To-D-83	3000	90	2520	38.0	12701	96	133	E	1848561	https://eprelec.europa.eu/qr/1848561
BXRE-35G65To-B-83	3500	90	2340	57.0	17269	133	130	E	1848571	https://eprelec.europa.eu/qr/1848571
BXRE-35G65To-C-83	3500	90	2700	57.0	20457	154	133	E	1848572	https://eprelec.europa.eu/qr/1848572
BXRE-35G65To-D-83	3500	90	2520	38.0	12803	96	134	E	1848573	https://eprelec.europa.eu/qr/1848573
BXRE-40G65To-B-83	4000	90	2340	57.0	17720	133	133	E	1848583	https://eprelec.europa.eu/qr/1848583
BXRE-40G65To-C-83	4000	90	2700	57.0	20940	154	136	E	1848584	https://eprelec.europa.eu/qr/1848584
BXRE-40G65To-D-83	4000	90	2520	38.0	13111	96	137	E	1848585	https://eprelec.europa.eu/qr/1848585

Notes for Table 3:

1. All device listed here must be disposed as e-waste upon its end of life according to local country guideline in each country.
2. For information on performance values at alternative drive conditions, please refer to the Product Selection Guide, Absolute Maximum Rating Table and Performance Curves in this data sheet.
3. For a definition of useful luminous flux (Φ_{use}), please see the ELR regulations at <https://tinyurl.com/4b6zvt4m>.
4. EPREL requires an arrow symbol containing the letter of the energy efficiency class to be displayed, on technical promotional material. Refer to this energy efficiency class column for specific energy efficiency class on each part number.

Performance at Commonly Used Drive Currents

V Series LED arrays are tested to the specifications shown using the nominal drive currents in Table 1. V Series may also be driven at other drive currents dependent on specific application design requirements. The performance at any drive current can be derived from the current vs. voltage characteristics shown in Figures 1, 2 & 3 and the flux vs. current characteristics shown in Figures 4, 5 & 6. The performance at commonly used drive currents is summarized in Table 4.

Table 4: Product Performance at Commonly Used Drive Currents

Part Number	CRI	Drive Current ¹ (mA)	Typical V _f T _c = 25°C (V)	Typical Power T _c = 25°C (W)	Typical Flux ² T _c = 25°C (lm)	Typical DC Flux ³ T _c = 85°C (lm)	Typical Efficacy T _c = 25°C (lm/W)
BXRE-27G65To-B-8x	90	475	49.4	23.4	4144	3812	177
		725	50.6	36.7	6223	5725	170
		950	51.6	49.0	8050	7406	164
		1170	52.6	61.5	9795	9012	159
		1900	55.6	105.6	15295	14072	145
		2340	57.2	133.8	17925	16491	134
BXRE-27G65To-C-8x	90	600	49.6	29.7	5234	4816	176
		900	50.8	45.7	7725	7107	169
		1200	52.0	62.4	10150	9338	163
		1440	52.9	76.2	12043	11079	158
		2400	56.2	134.9	19195	17659	142
		2700	57.2	154.3	21292	19589	138
BXRE-27G65To-D-8x	90	525	32.9	17.3	3060	2816	177
		785	33.7	26.5	4505	4145	170
		1050	34.5	36.2	5950	5474	164
		1400	35.4	49.6	7784	7161	157
		2100	37.2	78.1	11276	10374	144
		2520	38.1	96.0	13249	12189	138
BXRE-30G65To-B-8x	90	475	49.4	23.4	4298	3954	183
		725	50.6	36.7	6455	5939	176
		950	51.6	49.0	8350	7682	170
		1170	52.6	61.5	10160	9347	165
		1900	55.6	105.6	15865	14596	150
		2340	57.2	133.8	18593	17105	139
BXRE-30G65To-C-8x	90	600	49.6	29.7	5415	4982	182
		900	50.8	45.7	7991	7352	175
		1200	52.0	62.4	10500	9660	168
		1440	52.9	76.2	12458	11461	164
		2400	56.2	134.9	19857	18268	147
		2700	57.2	154.3	22026	20264	143
BXRE-30G65To-D-8x	90	525	32.9	17.3	3189	2934	184
		785	33.7	26.5	4695	4319	177
		1050	34.5	36.2	6200	5704	171
		1400	35.4	49.6	8111	7462	164
		2100	37.2	78.1	11750	10810	151
		2520	38.1	96.0	13805	12701	144

Notes for Table 4:

1. Alternate drive currents in Table 4 are provided for reference only and are not a guarantee of performance.
2. Bridgelux maintains a ± 7% tolerance on flux measurements.
3. Typical stabilized DC performance values are provided as reference only and are not a guarantee of performance.

Performance at Commonly Used Drive Currents

Table 4: Product Performance at Commonly Used Drive Currents (Continued)

Part Number	CRI	Drive Current ¹ (mA)	Typical V_f $T_c = 25^\circ\text{C}$ (V)	Typical Power $T_c = 25^\circ\text{C}$ (W)	Typical Flux ² $T_c = 25^\circ\text{C}$ (lm)	Typical DC Flux ³ $T_c = 85^\circ\text{C}$ (lm)	Typical Efficacy $T_c = 25^\circ\text{C}$ (lm/W)
BXRE-35G65To-B-8x	90	475	49.4	23.4	4339	3992	185
		725	50.6	36.7	6517	5996	178
		950	51.6	49.0	8430	7756	172
		1170	52.6	61.5	10257	9437	167
		1900	55.6	105.6	16017	14736	152
		2340	57.2	133.8	18771	17269	140
BXRE-35G65To-C-8x	90	600	49.6	29.7	5466	5029	184
		900	50.8	45.7	8067	7422	176
		1200	52.0	62.4	10600	9752	170
		1440	52.9	76.2	12577	11571	165
		2400	56.2	134.9	20046	18442	149
		2700	57.2	154.3	22236	20457	144
BXRE-35G65To-D-8x	90	525	32.9	17.3	3215	2957	186
		785	33.7	26.5	4733	4354	179
		1050	34.5	36.2	6250	5750	173
		1400	35.4	49.6	8176	7522	165
		2100	37.2	78.1	11844	10897	152
		2520	38.1	96.0	13917	12803	145
BXRE-40G65To-B-8x	90	475	49.4	23.4	4453	4097	190
		725	50.6	36.7	6687	6152	182
		950	51.6	49.0	8650	7958	176
		1170	52.6	61.5	10525	9683	171
		1900	55.6	105.6	16435	15120	156
		2340	57.2	133.8	19261	17720	144
BXRE-40G65To-C-8x	90	600	49.6	29.7	5595	5148	188
		900	50.8	45.7	8258	7597	181
		1200	52.0	62.4	10850	9982	174
		1440	52.9	76.2	12873	11844	169
		2400	56.2	134.9	20519	18877	152
		2700	57.2	154.3	22761	20940	147
BXRE-40G65To-D-8x	90	525	32.9	17.3	3292	3028	190
		785	33.7	26.5	4846	4459	183
		1050	34.5	36.2	6400	5888	177
		1400	35.4	49.6	8372	7703	169
		2100	37.2	78.1	12129	11158	155
		2520	38.1	96.0	14251	13111	148

Notes for Table 4:

1. Alternate drive currents in Table 4 are provided for reference only and are not a guarantee of performance.
2. Bridgelux maintains a $\pm 7\%$ tolerance on flux measurements.
3. Typical stabilized DC performance values are provided as reference only and are not a guarantee of performance.

Electrical Characteristics

Table 5: Electrical Characteristics

Part Number	Drive Current (mA)	Forward Voltage Pulsed, $T_c = 25^\circ\text{C}$ (V) ^{1, 2, 3, 8}			Typical Coefficient of Forward Voltage ⁴ $\Delta V_f / \Delta T_c$ (mV/ $^\circ\text{C}$)	Typical Thermal Resistance Junction to Case ^{5,6} R_{j-c} ($^\circ\text{C}/\text{W}$)	Driver Selection Voltages ⁷ (V)	
		Minimum	Typical	Maximum			V_f Min. Hot $T_c = 105^\circ\text{C}$ (V)	V_f Max. Cold $T_c = -40^\circ\text{C}$ (V)
BXRE-xxx65Tx-B-8x	950	48.5	51.6	54.7	-17	0.07	47.3	55.8
	2340	53.7	57.2	60.6	-19	0.13	52.4	61.8
BXRE-xxx65Tx-C-8x	1200	48.9	52.0	55.1	-17	0.08	47.7	56.2
	2700	53.7	57.2	60.6	-19	0.15	52.4	61.8
BXRE-xxx65Tx-D-8x	1050	32.4	34.5	36.5	-11	0.08	31.6	37.3
	2520	35.8	38.1	40.4	-13	0.14	34.9	41.2

Notes for Table 5:

- Parts are tested in pulsed conditions. $T_c = 25^\circ\text{C}$. Pulse width is 10ms.
- Voltage minimum and maximum are provided for reference only and are not a guarantee of performance.
- Bridgelux maintains a tester tolerance of $\pm 0.10\text{V}$ on forward voltage measurements.
- Typical coefficient of forward voltage tolerance is $\pm 0.1\text{mV}$ for nominal current.
- Thermal resistance values are based from test data of a 3000K 90 CRI product.
- Thermal resistance value was calculated using total electrical input power; optical power was not subtracted from input power. The thermal interface material used during testing is not included in the thermal resistance value.
- V_f min hot and max cold values are provided as reference only and are not guaranteed by test. These values are provided to aid in driver design and selection over the operating range of the product.
- This product has been designed and manufactured per IEC 62031:2018. This product has passed dielectric withstand voltage testing at 1140 V. The working voltage designated for the insulation is 70V d.c. The maximum allowable voltage across the array must be determined in the end product application.

Eye Safety

Table 6: Eye Safety Risk Group (RG) Classifications

Part Number	Drive Current (mA)	CCT ³	
		2700K/3000K	3500-4000K ²
BXRE-xxx65Tx-B-8x	1485	RG1	RG1
	2340	RG1	RG2
BXRE-xxx65Tx-C-8x	1515	RG1	RG1
	2500	RG1	RG2
	2700	RG2	RG2
BXRE-xxx65Tx-D-8x	2160	RG1	RG1
	2520	RG1	RG2

Notes for Table 6:

1. Eye safety classification for the use of Bridgelux V Series LED arrays is in accordance with specification IEC/TR 62778: Application of IEC 62471 for the assessment of blue light hazard to light sources and luminaires.
2. For products classified as RG2 at 4000K, Ethr= 1980 lx.
3. Please contact your Bridgelux sales representative for Ethr values at specific drive currents and CCTs not listed.

Absolute Maximum Ratings

Table 7: Maximum Ratings

Parameter	Maximum Rating		
LED Junction Temperature (T _J)	150°C		
Storage Temperature ¹	-40°C to +105°C		
Operating Case Temperature ² (T _C)	105°C ⁷		
Soldering Temperature ³	350°C or lower for a maximum of 6 seconds		
	BXRE-xxx65Tx-B-8x	BXRE-xxx65Tx-C-8x	BXRE-xxx65Tx-D-8x
Maximum Drive Current ⁴	2340 mA at ≤85°C 1560 mA at 105°C	2700 mA at ≤85°C 1800 mA at 105°C	2520 mA at ≤85°C 1680 mA at 105°C
Maximum Peak Pulsed Drive Current ⁵	3350 mA	3870 mA	3610mA
Maximum Reverse Voltage ⁶	-90V	-90V	-50V

Notes for Table 7:

1. The F90 product is robust enough to pass our internal humidity test but it is still more sensitive compared to regular LED array product. The product needs to be stored in a dry environment. It is not recommended to use the product in a damp environment that directly exposes it to moisture.
2. For IEC 62717 requirement, please consult your Bridgelux sales representative.
3. Refer to Bridgelux Application Note AN101: Handling and Assembly of Bridgelux V Series LED Arrays
4. Arrays may be driven at higher currents however lumen maintenance may be reduced and warranty will not apply.
5. Bridgelux recommends a maximum duty cycle of 10% and pulse width of 20 ms when operating LED Arrays at maximum peak pulsed current specified. Maximum peak pulsed currents indicate values where LED Arrays can be driven without catastrophic failures.
6. Light emitting diodes are not designed to be driven in reverse voltage and will not produce light under this condition. Maximum rating provided for reference only.
7. For good thermal management and to achieve optimal LED lifetime, please ensure that your thermal design accounts for the temperature of the light emitting surface (LES) to not exceed 140 deg C.

Performance Curves

Figure 1: V22B Drive Current vs. Voltage

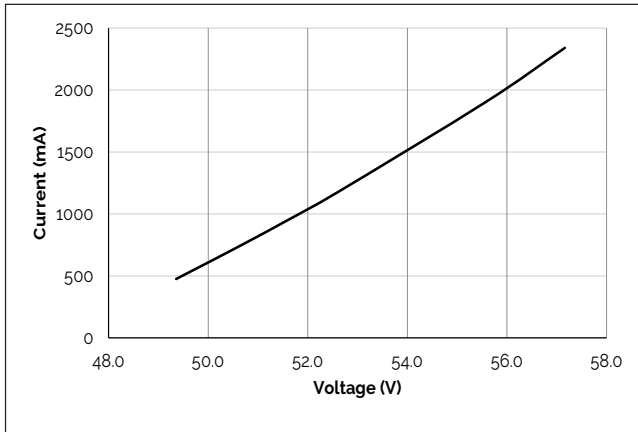

Figure 2: V22C Drive Current vs. Voltage

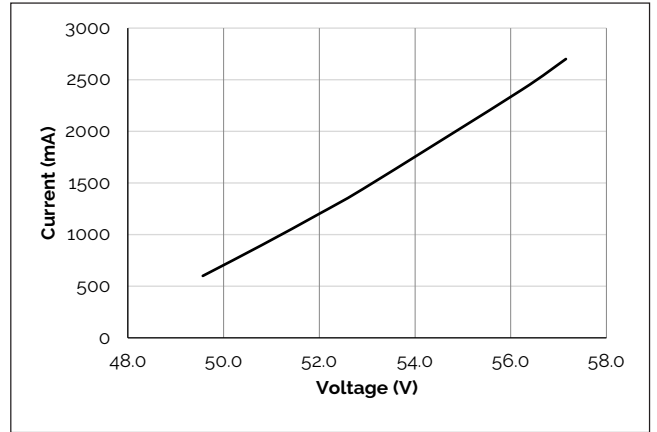

Figure 3: V22D Drive Current vs. Voltage

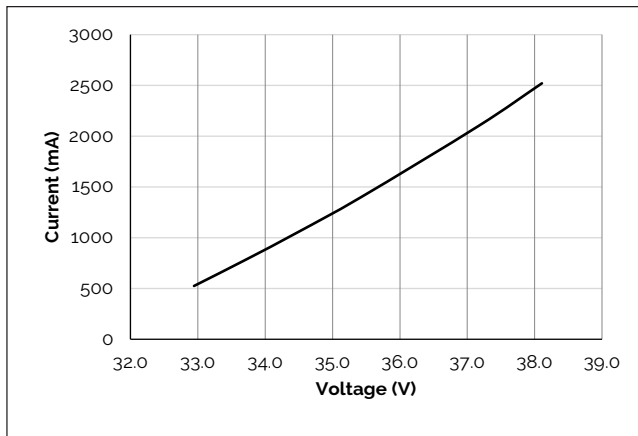

Figure 4: V22B Typical Relative Flux vs. Current

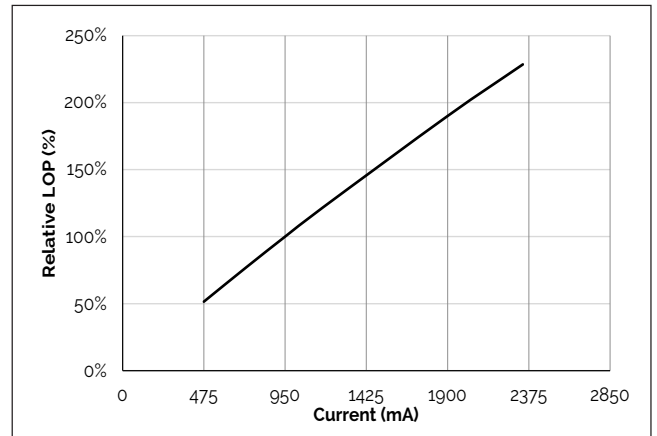

Figure 5: V22C Typical Relative Flux vs. Current

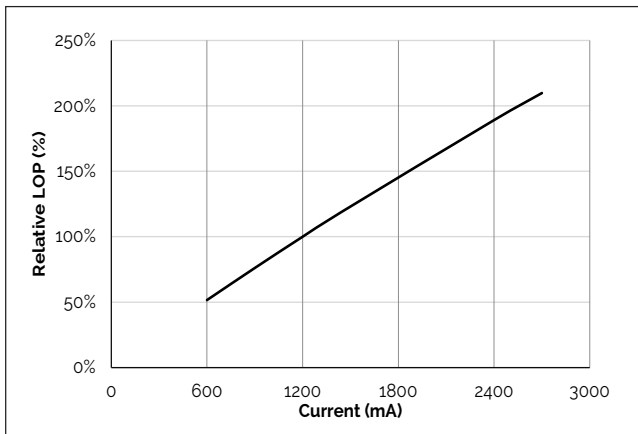
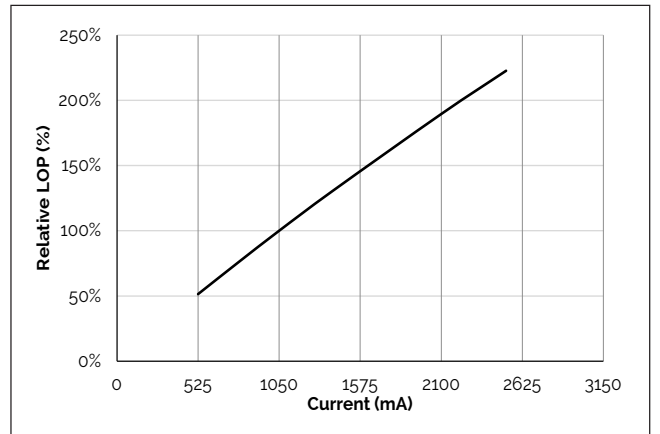

Figure 6: V22D Typical Relative Flux vs. Current



Notes for Figures 1-6:

1. Bridgelux does not recommend driving high power LEDs at low currents. Doing so may produce unpredictable results. Pulse width modulation (PWM) is recommended for dimming effects.
2. Products tested under pulsed condition (10ms pulse width) at nominal drive current where T_j (junction temperature) = T_c (case temperature) = 25°C.

Performance Curves

Figure 7: Typical DC Flux vs. Case Temperature

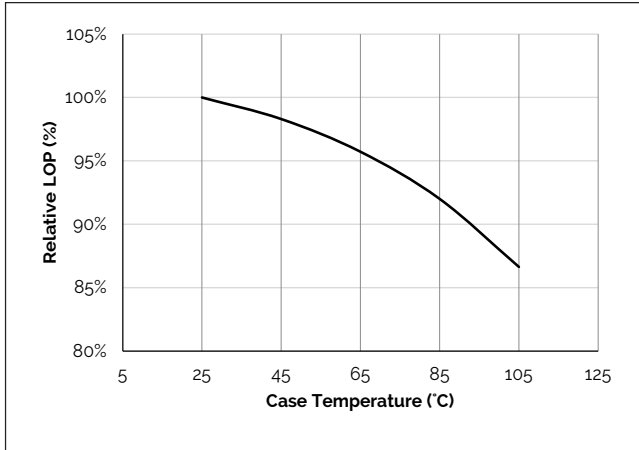

Figure 8: Typical DC ccx Shift vs. Case Temperature

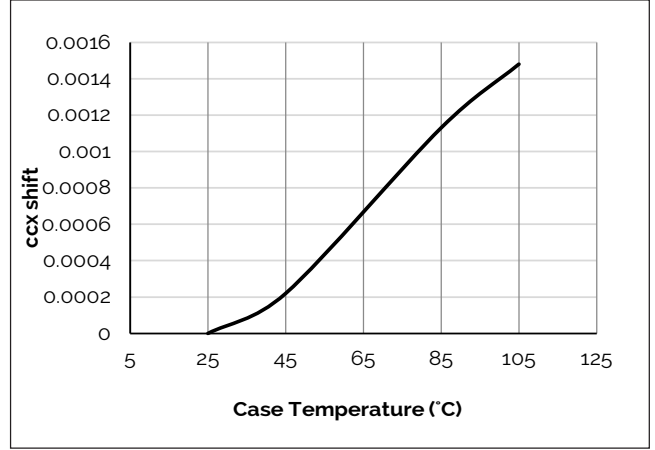

Figure 9: Typical DC ccy Shift vs. Case Temperature

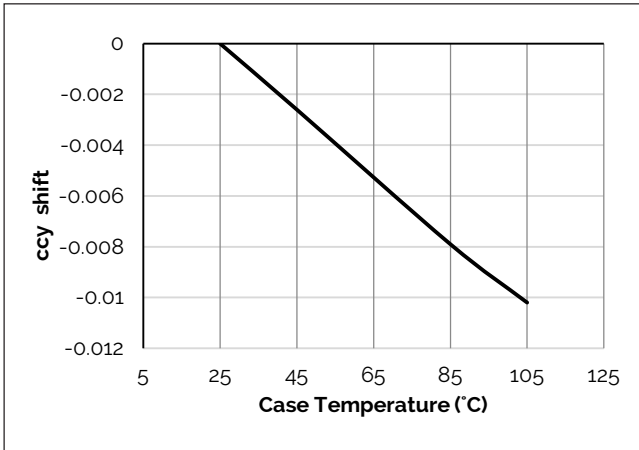

Figure 10: V22B Drive Current vs. ccx Shift

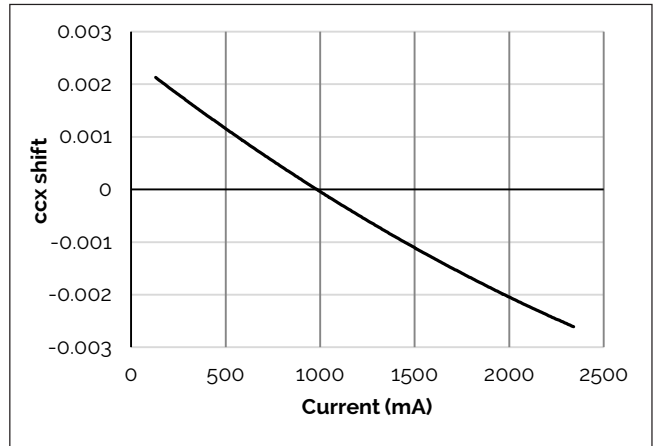

Figure 11: V22B Drive Current vs. ccy Shift

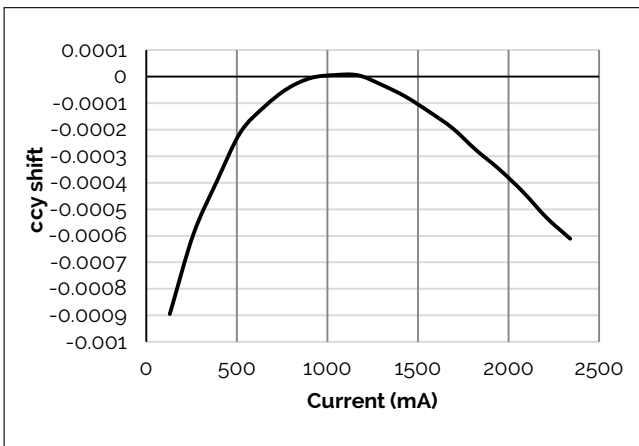
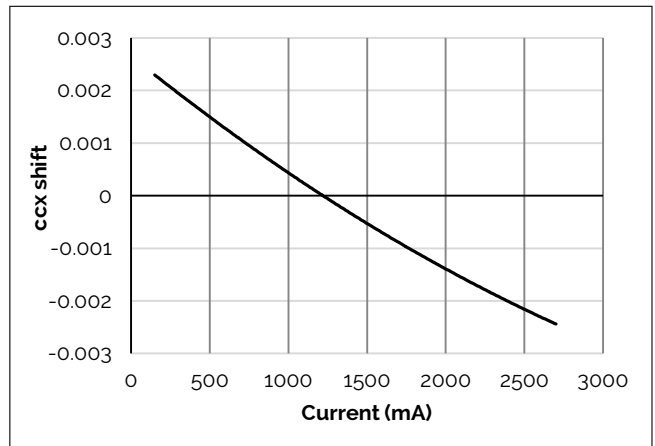

Figure 12: V22C Drive Current vs. ccx Shift



Note for Figures 7-12:

1. Characteristics shown for Warm White.

Performance Curves

Figure 13: V22C Drive Current vs. ccy Shift

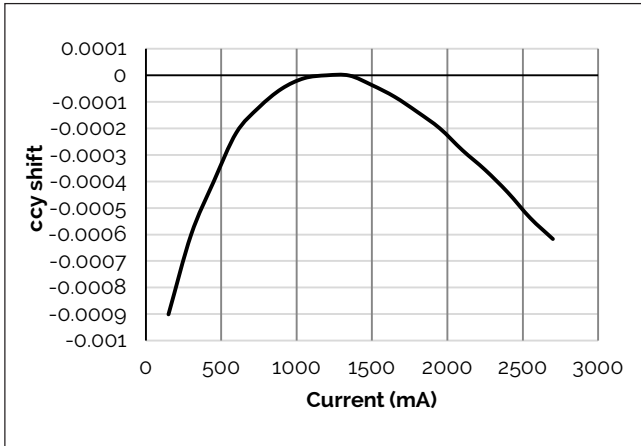

Figure 14: V22D Drive Current vs. ccx Shift

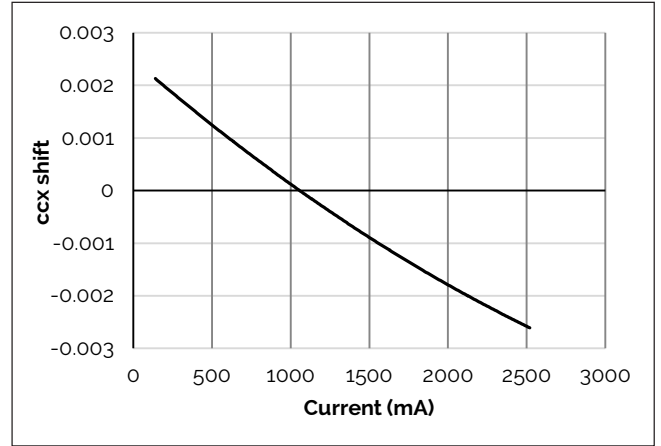

Figure 15: V22D Drive Current vs. ccy Shift

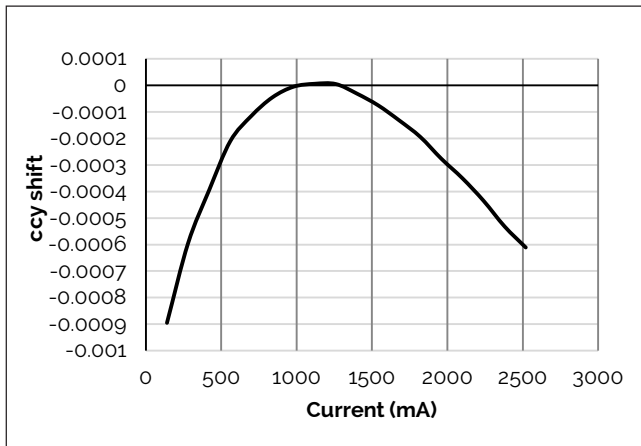
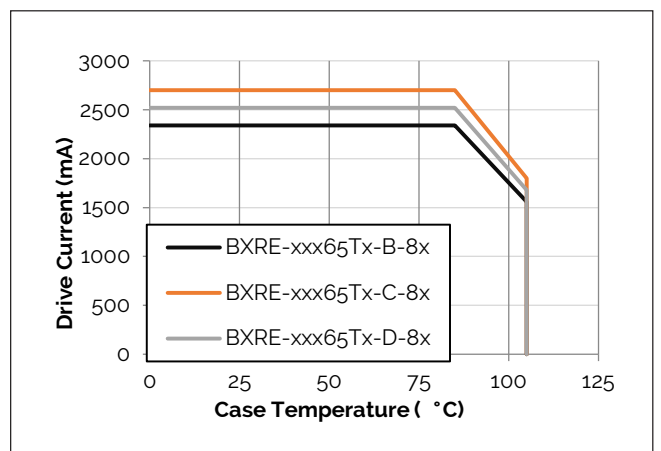

Figure 16: Derating Curve



Note for Figures 13-15:

1. Characteristics shown for Warm White.

Typical Radiation Pattern

Figure 17: Typical Spatial Radiation Pattern

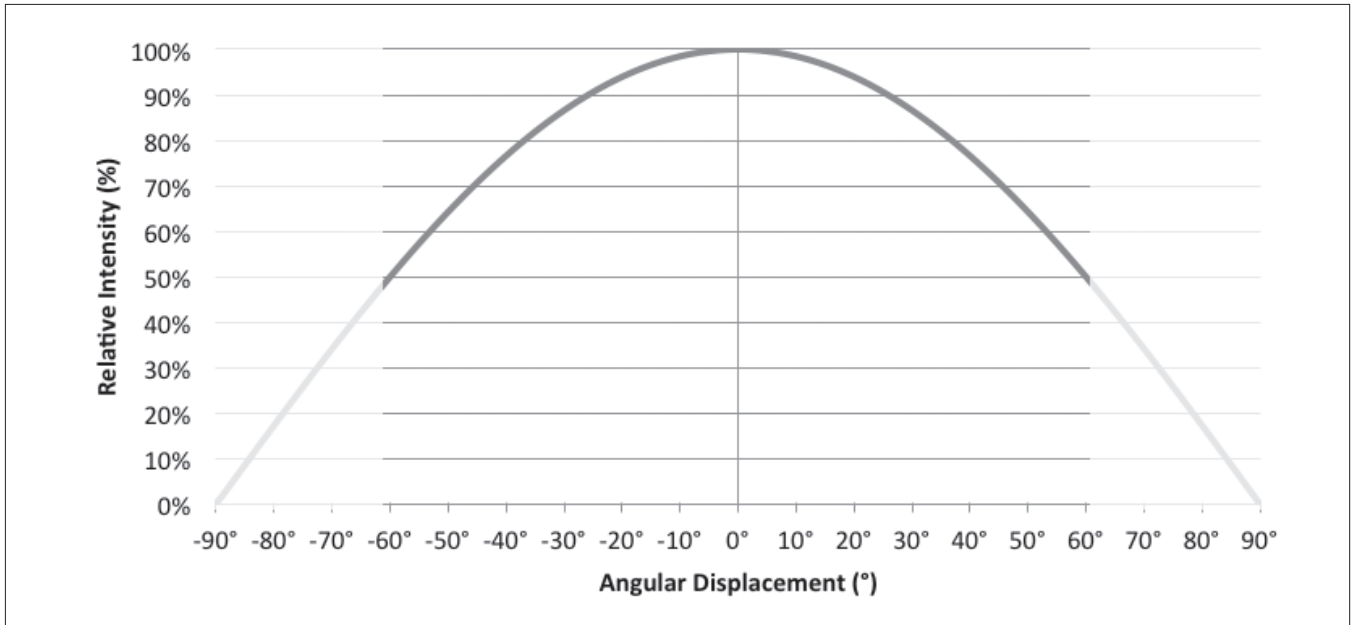

Notes for Figure 17:

1. Typical viewing angle is 120°.
2. The viewing angle is defined as the off axis angle from the centerline where intensity is ½ of the peak value.

Figure 18: Typical Polar Radiation Pattern

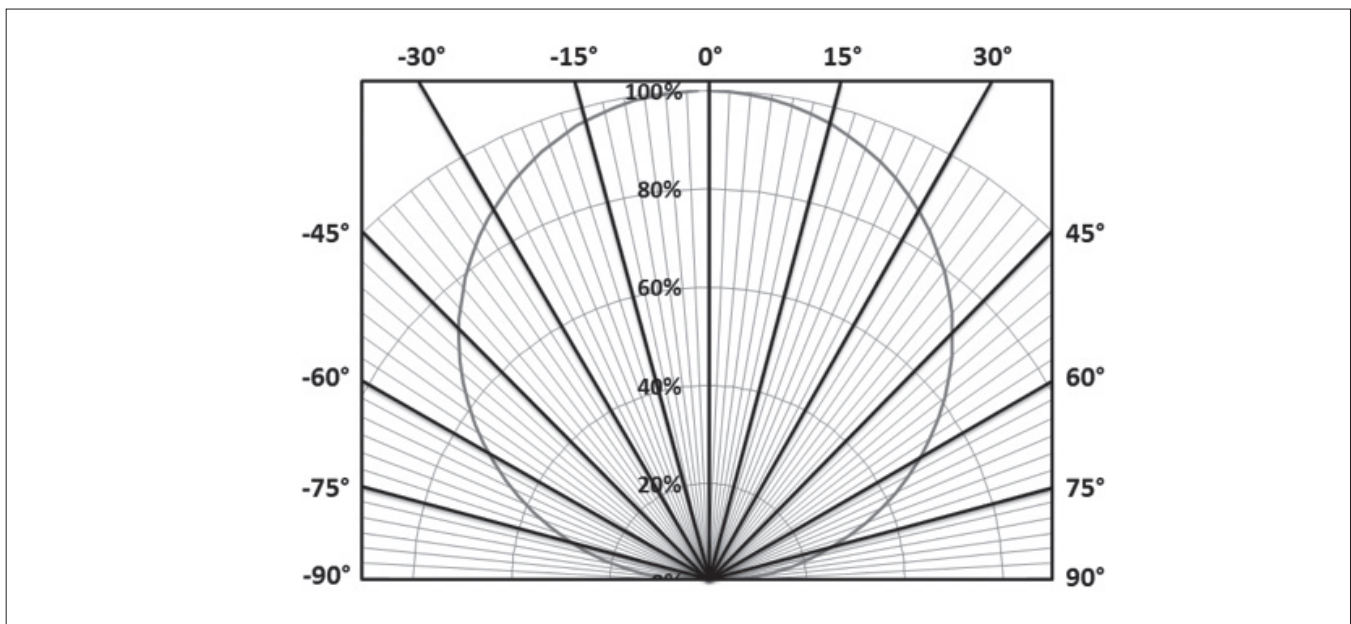

Typical Color Spectrum

Figure 19: Typical Color Spectrum

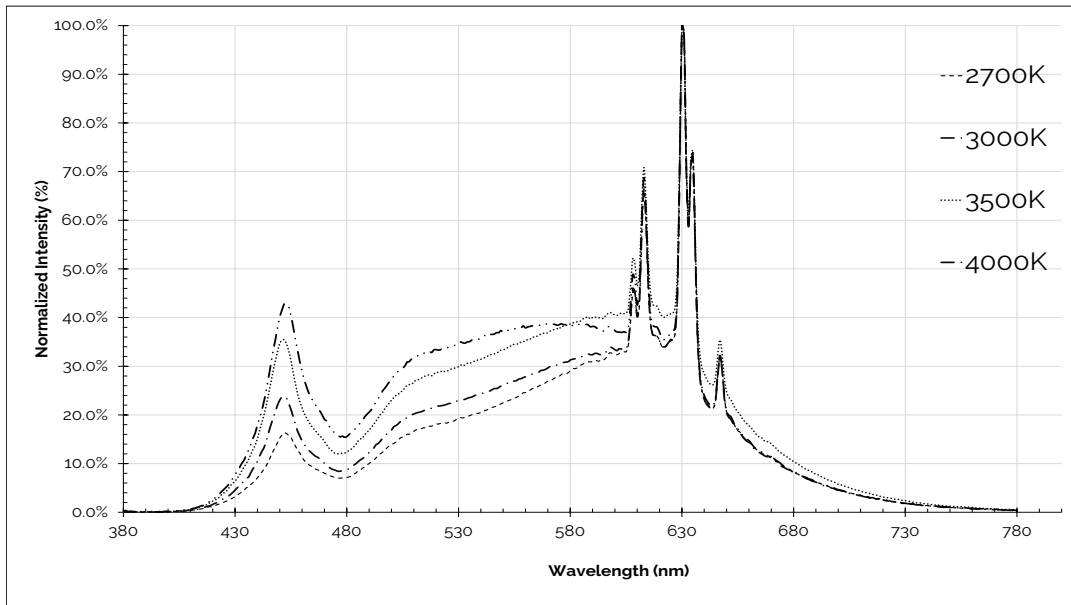

Notes for Figure 19:

1. Color spectra measured at nominal current for $T_j = T_c = 85^\circ\text{C}$.
2. Color spectra shown is 2700K and 90CRI.
3. Color spectra shown is 3000K and 90 CRI.
4. Color spectra shown is 3500K and 90 CRI.
5. Color spectra shown is 4000K and 90 CRI.

Mechanical Dimensions

Figure 20: Drawing for V22 LED Array

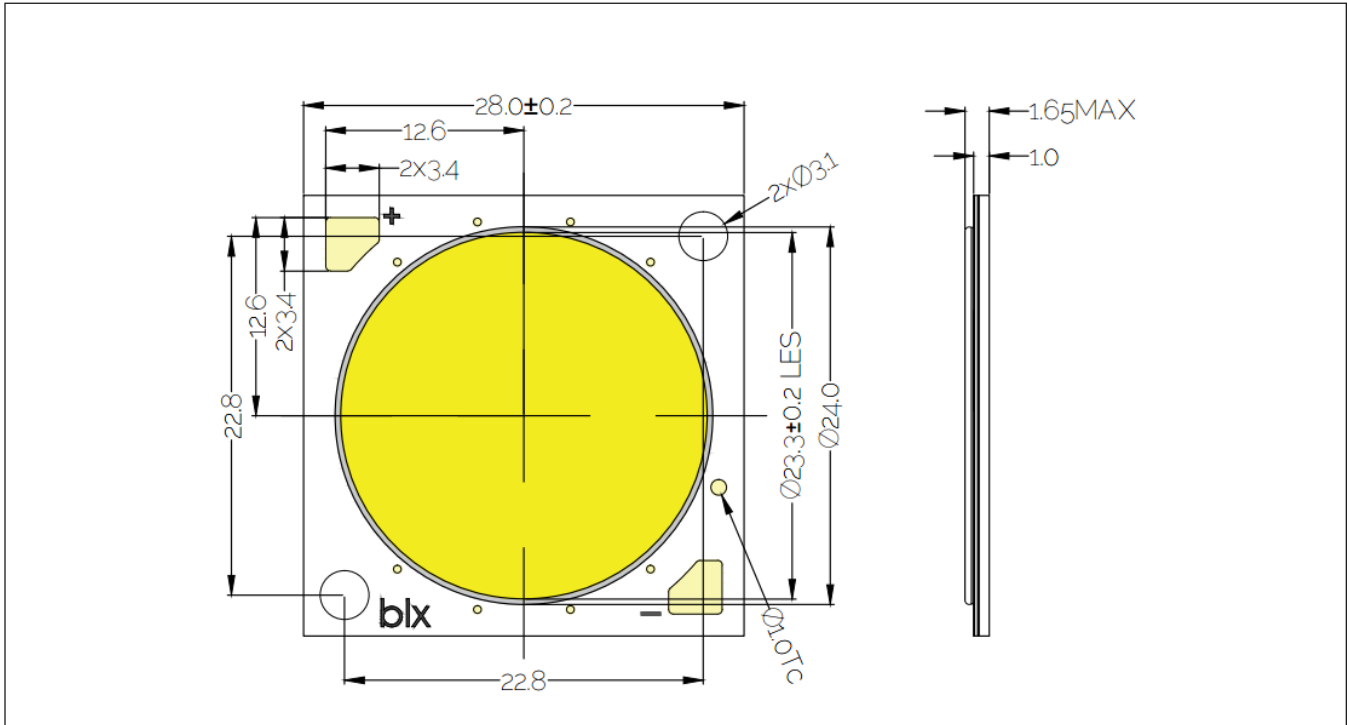

Notes for Figure 20:

1. Drawings are not to scale.
2. Drawing dimensions are in millimeters.
3. Unless otherwise specified, tolerances are ±0.1mm.
4. Solder pad labeled "+" denotes positive contact.
5. Refer to Application Notes AN101 for product handling, mounting and heat sink recommendations.
6. The optical center of the LED Array is nominally defined by the mechanical center of the array to a tolerance of ± 0.2mm.
7. Bridgelux maintains a flatness of 0.10mm across the mounting surface of the array.

Color Binning Information

Figure 21: Warm and Neutral White Test Bins in xy Color Space

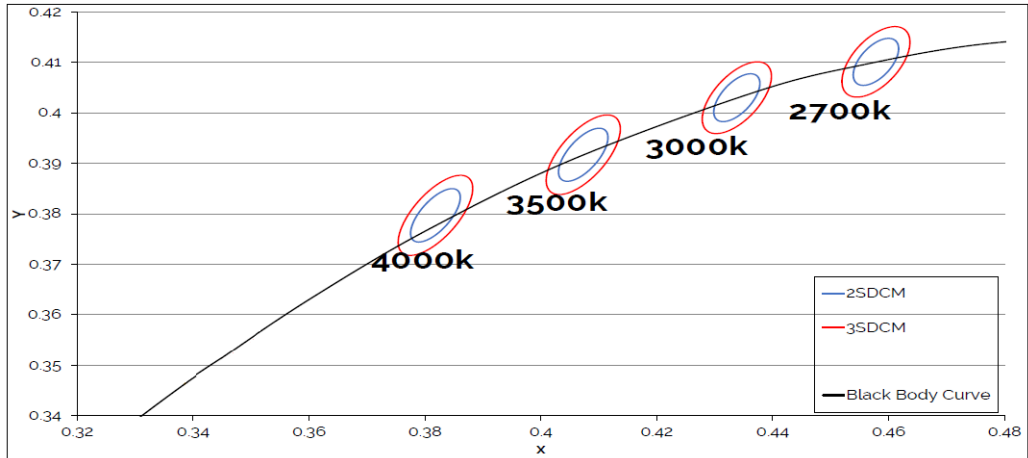

Note: Pulsed Test Conditions, $T_c = 85^\circ\text{C}$

Table 8: Warm and Neutral White xy Bin Coordinates and Associated Typical CCT (product is hot targeted to $T_c = 85^\circ\text{C}$)

Bin Code	2700K	3000K	3500K	4000K
ANSI Bin (for reference only)	(2580K - 2870K)	(2870K - 3220K)	(3220K - 3710K)	(3710K - 4260K)
83 (3 SDCM)	(2651K - 2794K)	(2968K - 3136K)	(3369K - 3586K)	(3851K - 4130K)
82 (2 SDCM)	(2674K - 2769K)	(2995K - 3107K)	(3404K - 3548K)	(3895K - 4081K)
Center Point (x,y)	(0.4578, 0.4101)	(0.4338, 0.403)	(0.4073, 0.3917)	(0.3818, 0.3797)

Note for Table 8:

1. Bridgelux maintains a tolerance of +/- 0.007 on x and y color coordinates in the CIE 1931 color Space.

Packaging and Labeling

Figure 22: Drawing for V22 Packaging Tube

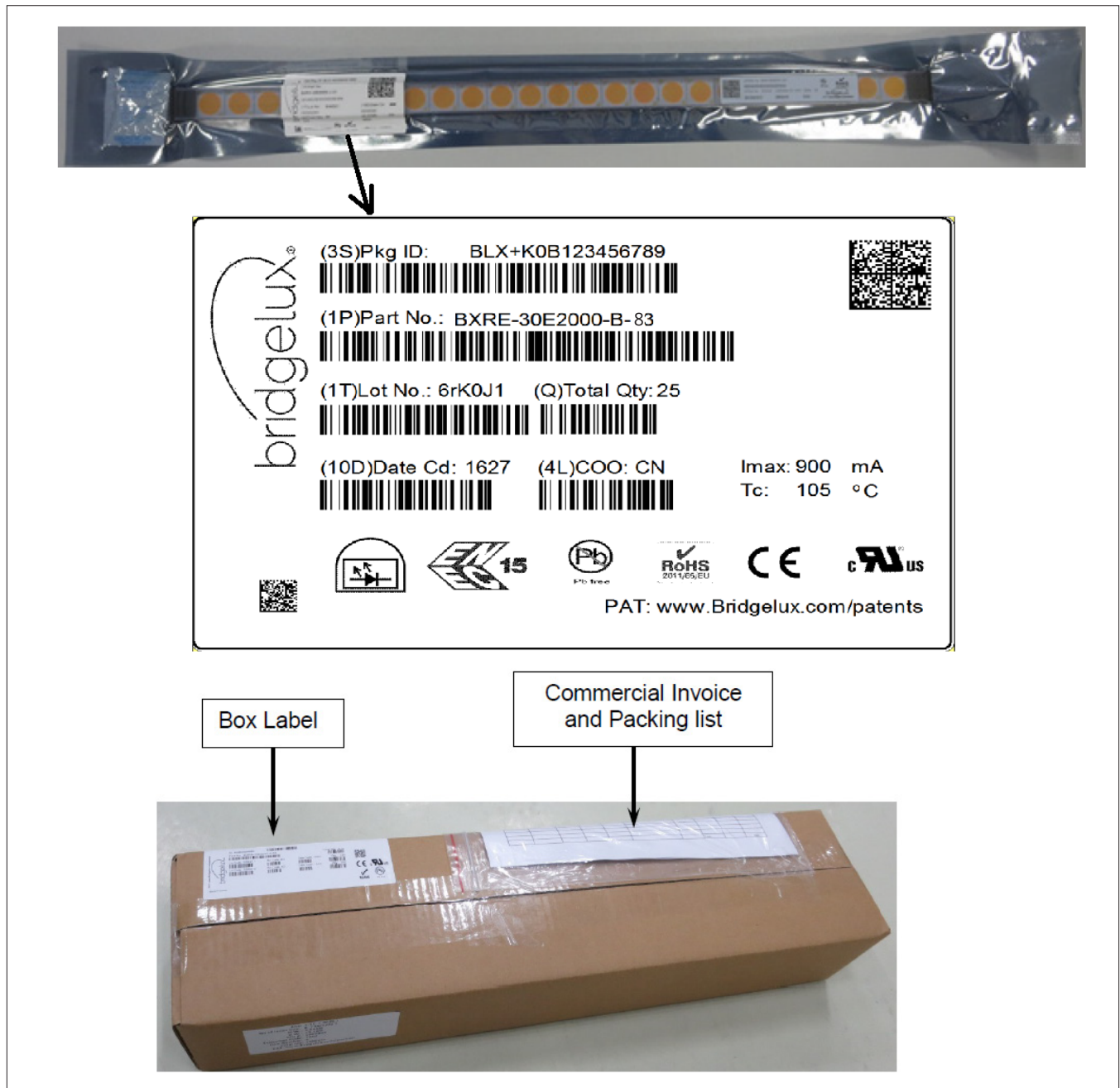

Notes for Figure 22:

1. Each tube holds 15 V22 COB arrays.
2. Four tubes are sealed in an anti-static bag. Four bags are placed in a shipping box and shipped. Depending on quantities ordered, a bigger shipping box, containing four boxes may be used to ship products.
3. Each bag and box is to be labeled as shown above.
4. Dimensions for each tube are 30.7 (W) x 9.65(H) x 460(L). Dimensions for the anti-static bag are 120mm (W) x 635mm (L) x 0.1 (T) mm. Dimensions for the shipping box are 58.7 x 13.3 x 7.9 cm.

Packaging and Labeling

Figure 23: Gen. 8 Product Labeling

Bridgelux COB arrays have laser markings on the back side of the substrate to help with product identification. In addition to the product identification markings, Bridgelux COB arrays also contain markings for internal Bridgelux manufacturing use only. The image below shows which markings are for customer use and which ones are for Bridgelux internal use only. The Bridgelux internal manufacturing markings are subject to change without notice, however these will not impact the form, function or performance of the COB array.



Design Resources

Application Notes

Bridgelux has developed a comprehensive set of application notes and design resources to assist customers in successfully designing with the V Series product family of LED array products. For all available application notes visit www.bridgelux.com.

Optical Source Models

Optical source models and ray set files are available for all Bridgelux products. For a list of available formats, visit www.bridgelux.com.

3D CAD Models

Three dimensional CAD models depicting the product outline of all Bridgelux V Series LED arrays are available in both IGS and STEP formats. Please contact your Bridgelux sales representative for assistance.

LM80

LM80 testing has been completed and the LM80 report is now available. Please contact your Bridgelux sales representative for LM-80 report.

Precautions

CAUTION: CHEMICAL EXPOSURE HAZARD

Exposure to some chemicals commonly used in luminaire manufacturing and assembly can cause damage to the LED array. Please consult Bridgelux Application Note AN101 for additional information.

CAUTION: RISK OF BURN

Do not touch the V Series LED array during operation. Allow the array to cool for a sufficient period of time before handling. The V Series LED array may reach elevated temperatures such that could burn skin when touched.

CAUTION

CONTACT WITH LIGHT EMITTING SURFACE (LES)

Avoid any contact with the LES. Do not touch the LES of the LED array or apply stress to the LES (yellow phosphor resin area). Contact may cause damage to the LED array.

Optics and reflectors must not be mounted in contact with the LES (yellow phosphor resin area).

Disclaimers

MINOR PRODUCT CHANGE POLICY

The rigorous qualification testing on products offered by Bridgelux provides performance assurance. Slight cosmetic changes that do not affect form, fit, or function may occur as Bridgelux continues product optimization.

STANDARD TEST CONDITIONS

Unless otherwise stated, array testing is performed at the nominal drive current.

About Bridgelux: Bridging Light and Life™

At Bridgelux, we help companies, industries and people experience the power and possibility of light. Since 2002, we've designed LED solutions that are high performing, energy efficient, cost effective and easy to integrate. Our focus is on light's impact on human behavior, delivering products that create better environments, experiences and returns—both experiential and financial. And our patented technology drives new platforms for commercial and industrial luminaires.

For more information about the company, please visit
bridgelux.com
twitter.com/Bridgelux
facebook.com/Bridgelux
youtube.com/user/Bridgelux
linkedin.com/company/bridgelux-inc-_2
WeChat ID: BridgeluxInChina



46410 Fremont Boulevard
Fremont, CA 94538 U.S.A.
Tel (925) 583-8400
www.bridgelux.com

© 2023 Bridgelux, Inc. All rights reserved. Product specifications are subject to change without notice. Bridgelux, the Bridgelux stylized logo design and Vero are registered trademarks. V Series and Decor Series are trademarks of Bridgelux, Inc. All other trademarks are the property of their respective owners.

Bridgelux Gen 8 V22 F90 TS Array Series Product Data Sheet DS1322 Rev. A (11/2023)