



# Bridgelux® Vero® 10 F90 Array

Product Data Sheet DS419



# Introduction

Vero® F90



The Vero® Series is a revolutionary advancement in chip on board (COB) light source technology and innovation, simplifying the luminaire design and manufacturing processes. Vero Chip on Board (COB) LED arrays are available in four LES configurations, engineered to enable new degrees of flexibility and reliability over a broad range of electrical currents. Vero arrays deliver increased lumen density to enable improved beam control and precision lighting with 2 and 3 SDCM color control standard for clean and consistent uniform lighting.

Vero products include an onboard connector port that enables a solder-free electrical interconnect, and simple mounting features for plug-and-play installation.

The F90 Vero Series COB is a high efficacy product that uses narrow band red phosphor to significantly improve the spectrum efficacy. The improved spectrum efficacy results in the 90 CRI product of the F90 Series delivering better or equivalent efficacy as that of our traditional 80 CRI Vero Series product.

## Features

- Efficacy of 182 lm/W typical, 3000K 90 CRI
- Wide selection of CCT options (2700K-5000K) with minimum 90 CRI options
- Uniform high-quality illumination
- 2 and 3 SDCM binning options (2700K – 4000K)
- 3 and 4 SDCM binning options (5000K)
- Forward voltage bin codes and backside marking
- Instant light with unlimited dimming
- Thermally isolated solder pads
- 10-Year warranty

## Benefits

- Solder free installation and field upgradability
- Improved inventory management and quality control
- Enables high efficiency lighting systems and lower operating costs
- Supports the trend toward luminaire miniaturization and delivers enhanced optical control
- Design flexibility for a broad range of lighting applications
- Clean white light without pixelation
- Uniform consistent white light
- Design flexibility for multi-source applications
- Enhanced ease of use and installation



# Contents

Product Feature Map	2
Product Nomenclature	2
Product Selection Guide	3
European Product Registry for Energy Labeling	4
Performance at Commonly Used Drive Currents	5
Electrical Characteristics	7
Eye Safety	8
Absolute Maximum Ratings	9
Performance Curves	10
Typical Radiation Pattern	12
Typical Color Spectrum	13
Product Bin Definitions	14
Mechanical Dimensions	15
Packaging and Labeling	16
Design Resources	18
Precautions	18
Disclaimers	18
About Bridgelux	19

# Product Feature Map

Vero 10 is the smallest form factor in the Vero family of next generation solid state light sources. In addition to delivering the performance and light quality required for many lighting applications, Vero incorporates several

features to simplify the design integration and manufacturing process, accelerate time to market and reduce system costs. Please visit [www.bridgelux.com](http://www.bridgelux.com) for more information on the Vero Series family of products.

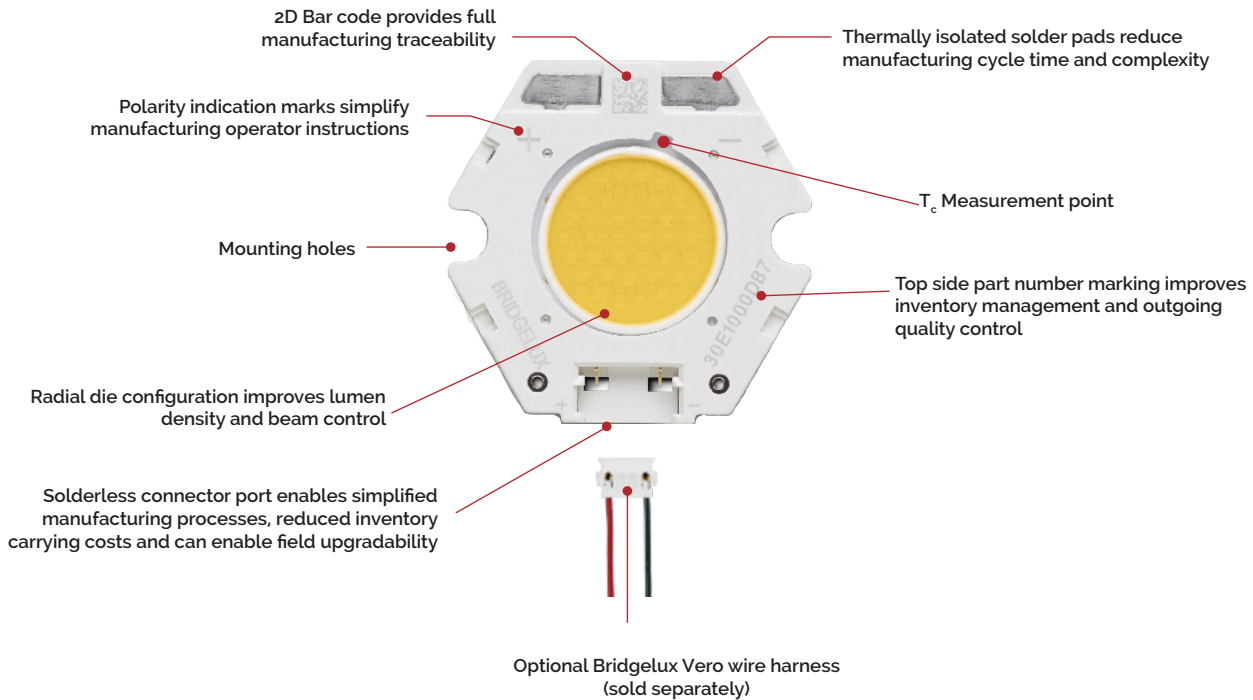

## Product Nomenclature

The part number designation for Bridgelux COB arrays is explained as follows:

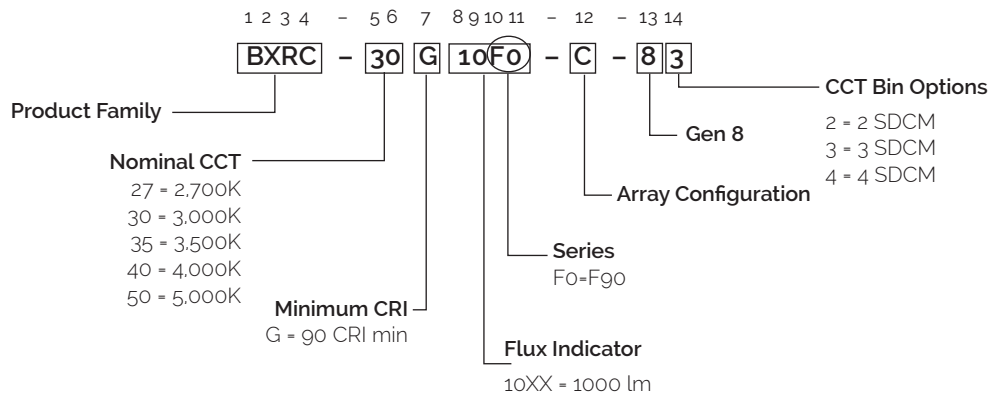

# Product Selection Guide

The following product configurations are available:

**Table 1:** Selection Guide, Pulsed Measurement Data ( $T_c = 25^\circ\text{C}$ )

Part Number	Nominal CCT <sup>1</sup> (K)	CRI <sup>2</sup>	Nominal Drive Current <sup>3</sup> (mA)	Typical Pulsed Flux <sup>4,5,6</sup> $T_c = 25^\circ\text{C}$ (lm)	Minimum Pulsed Flux <sup>6,7</sup> $T_c = 25^\circ\text{C}$ (lm)	Typical $V_f$ (V)	Typical Power (W)	Typical Efficacy (lm/W)
BXRC-27G10F0-B-8x	2700	90	200	1218	1096	34.1	6.8	178
BXRC-27G10F0-C-8x	2700	90	300	1682	1513	31.6	9.5	177
BXRC-30G10F0-B-8x	3000	90	200	1243	1119	34.1	6.8	182
BXRC-30G10F0-C-8x	3000	90	300	1716	1544	31.6	9.5	181
BXRC-35G10F0-B-8x	3500	90	200	1255	1130	34.1	6.8	184
BXRC-35G10F0-C-8x	3500	90	300	1733	1560	31.6	9.5	183
BXRC-40G10F0-B-8x	4000	90	200	1268	1141	34.1	6.8	186
BXRC-40G10F0-C-8x	4000	90	300	1750	1575	31.6	9.5	185
BXRC-50G10F0-B-8x	5000	90	200	1231	1108	34.1	6.8	180
BXRC-50G10F0-C-8x	5000	90	300	1699	1529	31.6	9.5	179

**Table 2:** Selection Guide, Stabilized DC Test Performance ( $T_c = 85^\circ\text{C}$ )<sup>4,5,6</sup>

Part Number	Nominal CCT (K)	CRI <sup>2</sup>	Nominal Drive Current <sup>3</sup> (mA)	Typical DC Flux <sup>4,5</sup> $T_c = 85^\circ\text{C}$ (lm)	Minimum DC Flux <sup>6</sup> $T_c = 85^\circ\text{C}$ (lm)	Typical $V_f$ (V)	Typical Power (W)	Typical Efficacy (lm/W)
BXRC-27G10F0-B-8x	2700	90	200	1121	1009	33.4	6.7	168
BXRC-27G10F0-C-8x	2700	90	300	1547	1392	30.9	9.3	167
BXRC-30G10F0-B-8x	3000	90	200	1144	1029	33.4	6.7	171
BXRC-30G10F0-C-8x	3000	90	300	1579	1421	30.9	9.3	170
BXRC-35G10F0-B-8x	3500	90	200	1155	1040	33.4	6.7	173
BXRC-35G10F0-C-8x	3500	90	300	1594	1435	30.9	9.3	172
BXRC-40G10F0-B-8x	4000	90	200	1166	1050	33.4	6.7	175
BXRC-40G10F0-C-8x	4000	90	300	1610	1449	30.9	9.3	174
BXRC-50G10F0-B-8x	5000	90	200	1132	1019	33.4	6.7	169
BXRC-50G10F0-C-8x	5000	90	300	1563	1407	30.9	9.3	168

Notes for Table 1 & 2:

- Nominal CCT as defined by ANSI C78.377-2011.
- CRI values are minimums and tested at  $T_j = T_c = 85^\circ\text{C}$ . Minimum Rg value for 90 CRI products is 50. Bridgelux maintains a  $\pm 3$  tolerance on CRI and Rg values.
- Drive current is referred to as nominal drive current.
- Products tested under pulsed condition (10ms pulse width) at nominal test current where  $T_j$  (junction temperature) -  $T_c$  (case temperature) =  $25^\circ\text{C}$ .
- Typical performance values are provided as a reference only and are not a guarantee of performance.
- Bridgelux maintains a  $\pm 7\%$  tolerance on flux measurements.
- Minimum flux values at the nominal test current are guaranteed by 100% test.

# European Product Registry for Energy Labeling

The European Product Registry for Energy Labeling (EPREL) is defined in the EU Regulation 2017/1369 to provide important energy efficiency information to consumers. Together with Energy Labeling Regulation ELR (EU) 2019/2015 which was amended by regulation (EU) 2021/340 for energy labelling of light sources, manufacturers are required to declare an energy class based on key technical specifications from each of their product and register it in an open data base managed by EPREL. It is now a legal requirement for a vendor of light sources to upload information about their products into the EPREL database before placing these products on the market in the EU.

Table 3 below provides a list of part numbers that are in compliance with ELR and are currently listed in the EPREL database.

At Bridgelux, we are fully committed to supplying products that are compliant with pertinent laws, rules, and obligation imposed by relevant government bodies including the European Energy Labeling regulation. Customers can use these products with full confidence for any projects that fall under the ELR.

**Table 3:** Part numbers registered in European Product Registry for Energy Labeling

PART NUMBER <sup>1</sup>	CCT (K)	CRI	Current <sup>2</sup> (mA)	Vf (V)	Useful flux <sup>3</sup> ( $\Phi_{use}$ ) at 85C (lm)	Power (W)	Efficacy (lm/W)	Energy efficiency class <sup>4</sup>	Registration No	URL to Product Information Sheet in EPREL Database
BXRC-27G10F0-B-83	2700	90	540	38.0	2651	21	129	E	1353214	<a href="https://eprelec.europa.eu/qr/1353214">https://eprelec.europa.eu/qr/1353214</a>
BXRC-27G10F0-C-83	2700	90	720	34.8	3282	25	131	E	1353215	<a href="https://eprelec.europa.eu/qr/1353215">https://eprelec.europa.eu/qr/1353215</a>
BXRC-30G10F0-B-83	3000	90	540	38.0	2705	21	132	E	1353216	<a href="https://eprelec.europa.eu/qr/1353216">https://eprelec.europa.eu/qr/1353216</a>
BXRC-30G10F0-C-83	3000	90	720	34.8	3349	25	134	E	1353217	<a href="https://eprelec.europa.eu/qr/1353217">https://eprelec.europa.eu/qr/1353217</a>
BXRC-35G10F0-B-83	3500	90	540	38.0	2732	21	133	E	1353218	<a href="https://eprelec.europa.eu/qr/1353218">https://eprelec.europa.eu/qr/1353218</a>
BXRC-35G10F0-C-83	3500	90	720	34.8	3382	25	135	E	1353219	<a href="https://eprelec.europa.eu/qr/1353219">https://eprelec.europa.eu/qr/1353219</a>
BXRC-40G10F0-B-83	4000	90	540	38.0	2759	21	134	E	1353220	<a href="https://eprelec.europa.eu/qr/1353220">https://eprelec.europa.eu/qr/1353220</a>
BXRC-40G10F0-C-83	4000	90	720	34.8	3416	25	136	E	1353221	<a href="https://eprelec.europa.eu/qr/1353221">https://eprelec.europa.eu/qr/1353221</a>
BXRC-50G10F0-B-84	5000	90	540	38.0	2678	21	131	E	1353222	<a href="https://eprelec.europa.eu/qr/1353222">https://eprelec.europa.eu/qr/1353222</a>
BXRC-50G10F0-C-84	5000	90	720	34.8	3315	25	132	E	1353223	<a href="https://eprelec.europa.eu/qr/1353223">https://eprelec.europa.eu/qr/1353223</a>

Notes for Table 3:

1. All device listed here must be disposed as e-waste upon its end of life according to local country guideline in each country.
2. For information on performance values at alternative drive conditions, please refer to the Product Selection Guide, Absolute Maximum Rating Table and Performance Curves in this data sheet.
3. For a definition of useful luminous flux ( $\Phi_{use}$ ), please see the ELR regulations at <https://tinyurl.com/4b6zvt4m>.
4. EPREL requires an arrow symbol containing the letter of the energy efficiency class to be displayed, on technical promotional material. Refer to this energy efficiency class column for specific energy efficiency class on each part number.

# Performance at Commonly Used Drive Currents

Vero LED arrays are tested to the specifications shown using the nominal drive currents in Table 1. Vero may also be driven at other drive currents dependent on specific application design requirements. The performance at any drive current can be derived from the current vs. voltage characteristics shown in Figures 1 & 2 and the flux vs. current characteristics shown in Figures 3 & 4. The performance at commonly used drive currents is summarized in Table 4.

**Table 4:** Product Performance at Commonly Used Drive Currents

Part Number	CRI	Drive Current <sup>1</sup> (mA)	Typical $V_f$ $T_c = 25^\circ\text{C}$ (V)	Typical Power $T_c = 25^\circ\text{C}$ (W)	Typical Flux <sup>2</sup> $T_c = 25^\circ\text{C}$ (lm)	Typical DC Flux <sup>3</sup> $T_c = 85^\circ\text{C}$ (lm)	Typical Efficacy $T_c = 25^\circ\text{C}$ (lm/W)
BXRC-27G10F0-B-8x	90	100	32.9	3.3	620	570	188
		150	33.6	5.0	922	848	183
		<b>200</b>	<b>34.1</b>	<b>6.8</b>	<b>1218</b>	<b>1121</b>	<b>178</b>
		270	34.9	9.4	1622	1492	172
		400	36.3	14.5	2337	2150	161
		540	37.7	20.3	3059	2815	150
BXRC-27G10F0-C-8x	90	150	30.4	4.6	858	790	188
		225	31.0	7.0	1275	1173	183
		<b>300</b>	<b>31.6</b>	<b>9.5</b>	<b>1682</b>	<b>1547</b>	<b>177</b>
		360	32.1	11.5	2000	1840	173
		600	33.8	20.3	3207	2951	158
		720	34.6	24.9	3773	3471	152
BXRC-30G10F0-B-8x	90	100	32.9	3.3	633	582	192
		150	33.6	5.0	941	866	187
		<b>200</b>	<b>34.1</b>	<b>6.8</b>	<b>1243</b>	<b>1144</b>	<b>182</b>
		270	34.9	9.4	1655	1522	175
		400	36.3	14.5	2385	2194	164
		540	37.7	20.3	3122	2872	153
BXRC-30G10F0-C-8x	90	150	30.4	4.6	876	806	192
		225	31.0	7.0	1301	1197	187
		<b>300</b>	<b>31.6</b>	<b>9.5</b>	<b>1716</b>	<b>1579</b>	<b>181</b>
		360	32.1	11.5	2040	1877	177
		600	33.8	20.3	3273	3011	161
		720	34.6	24.9	3849	3542	155
BXRC-35G10F0-B-8x	90	100	32.9	3.3	639	588	194
		150	33.6	5.0	950	874	189
		<b>200</b>	<b>34.1</b>	<b>6.8</b>	<b>1255</b>	<b>1155</b>	<b>184</b>
		270	34.9	9.4	1671	1538	177
		400	36.3	14.5	2409	2216	166
		540	37.7	20.3	3153	2901	155
BXRC-35G10F0-C-8x	90	150	30.4	4.6	885	814	194
		225	31.0	7.0	1314	1209	188
		<b>300</b>	<b>31.6</b>	<b>9.5</b>	<b>1733</b>	<b>1594</b>	<b>183</b>
		360	32.1	11.5	2061	1896	179
		600	33.8	20.3	3305	3041	163
		720	34.6	24.9	3888	3577	156

Notes for Table 4:

1. Alternate drive currents in Table 4 are provided for reference only and are not a guarantee of performance.
2. Bridgelux maintains a  $\pm 7\%$  tolerance on flux measurements.
3. Typical stabilized DC performance values are provided as reference only and are not a guarantee of performance.

# Performance at Commonly Used Drive Currents

**Table 4:** Product Performance at Commonly Used Drive Currents (Continued)

Part Number	CRI	Drive Current <sup>1</sup> (mA)	Typical $V_f$ $T_c = 25^\circ\text{C}$ (V)	Typical Power $T_c = 25^\circ\text{C}$ (W)	Typical Flux <sup>2</sup> $T_c = 25^\circ\text{C}$ (lm)	Typical DC Flux <sup>3</sup> $T_c = 85^\circ\text{C}$ (lm)	Typical Efficacy $T_c = 25^\circ\text{C}$ (lm/W)
BXRC-40G10F0-B-8x	90	100	32.9	3.3	645	608	196
		150	33.6	5.0	960	894	191
		<b>200</b>	<b>34.1</b>	<b>6.8</b>	<b>1268</b>	<b>1166</b>	<b>186</b>
		270	34.9	9.4	1688	1525	179
		400	36.3	14.5	2433	2121	167
		540	37.7	20.3	3184	2660	156
BXRC-40G10F0-C-8x	90	150	30.4	4.6	893	842	196
		225	31.0	7.0	1327	1236	190
		<b>300</b>	<b>31.6</b>	<b>9.5</b>	<b>1750</b>	<b>1610</b>	<b>185</b>
		360	32.1	11.5	2081	1895	180
		600	33.8	20.3	3338	2910	165
		720	34.6	24.9	3926	3343	158
BXRC-50G10F0-B-8x	90	100	32.9	3.3	626	590	190
		150	33.6	5.0	932	868	185
		<b>200</b>	<b>34.1</b>	<b>6.8</b>	<b>1231</b>	<b>1132</b>	<b>180</b>
		270	34.9	9.4	1638	1480	174
		400	36.3	14.5	2361	2059	162
		540	37.7	20.3	3091	2582	152
BXRC-50G10F0-C-8x	90	150	30.4	4.6	867	817	190
		225	31.0	7.0	1288	1200	185
		<b>300</b>	<b>31.6</b>	<b>9.5</b>	<b>1699</b>	<b>1563</b>	<b>179</b>
		360	32.1	11.5	2020	1840	175
		600	33.8	20.3	3240	2825	160
		720	34.6	24.9	3811	3244	153

Notes for Table 4:

1. Alternate drive currents in Table 4 are provided for reference only and are not a guarantee of performance.
2. Bridgelux maintains a  $\pm 7\%$  tolerance on flux measurements.
3. Typical stabilized DC performance values are provided as reference only and are not a guarantee of performance.



# Electrical Characteristics

**Table 5:** Electrical Characteristics

Part Number	Drive Current (mA)	Forward Voltage Pulsed, $T_c = 25^\circ\text{C}$ (V) <sup>1, 2, 3, 8</sup>			Typical Coefficient of Forward Voltage <sup>4</sup> $\Delta V_f / \Delta T_c$ (mV/ $^\circ\text{C}$ )	Typical Thermal Resistance Junction to Case <sup>5,6</sup> $R_{j-c}$ ( $^\circ\text{C}/\text{W}$ )	Driver Selection Voltages <sup>7</sup> (V)	
		Minimum	Typical	Maximum			$V_f$ Min. Hot $T_c = 105^\circ\text{C}$ (V)	$V_f$ Max. Cold $T_c = -40^\circ\text{C}$ (V)
BXRC-xxx10F0-B-8x	200	32.1	34.1	36.2	-9.55	0.62	31.4	36.8
	540	35.4	37.7	39.9	-10.54	0.95	34.7	40.6
BXRC-xxx10F0-C-8x	300	29.7	31.6	33.5	-8.84	0.38	29.1	34.1
	720	32.5	34.6	36.7	-9.67	0.55	31.8	37.3

Notes for Table 5:

- Parts are tested in pulsed conditions,  $T_c = 25^\circ\text{C}$ . Pulse width is 10ms.
- Voltage minimum and maximum are provided for reference only and are not a guarantee of performance.
- Bridgelux maintains a tester tolerance of  $\pm 0.10\text{V}$  on forward voltage measurements.
- Typical coefficient of forward voltage tolerance is  $\pm 0.1\text{mV}$  for nominal current.
- Thermal resistance values are based from test data of a 3000K 80 CRI product.
- Thermal resistance value was calculated using total electrical input power; optical power was not subtracted from input power. The thermal interface material used during testing is not included in the thermal resistance value.
- $V_f$  min hot and max cold values are provided as reference only and are not guaranteed by test. These values are provided to aid in driver design and selection over the operating range of the product.
- This product has been designed and manufactured per IEC 62031:2018. This product has passed dielectric withstand voltage testing at 1160 V. The working voltage designated for the insulation is 80V d.c. The maximum allowable voltage across the array must be determined in the end product application.

# Eye Safety

**Table 6:** Eye Safety Risk Group (RG) Classifications

Part Number	Drive Current (mA)	CCT <sup>3</sup>	
		2700K/3000K/3500K/4000K	5000K <sup>2</sup>
BXRC-xxx10F0-B-8x	540	RG1	RG1
BXRC-xxx10F0-C-8x	550	RG1	RG1
	720	RG1	RG2

Notes for Table 6:

1. Eye safety classification for the use of Bridgelux Vero Series LED arrays is in accordance with specification IEC/TR 62778: Application of IEC 62471 for the assessment of blue light hazard to light sources and luminaires.
2. For products classified as RG2 at 5000K Ethr= 1530 lx.
3. Please contact your Bridgelux sales representative for Ethr values at specific drive currents and CCTs not listed.

# Absolute Maximum Ratings

**Table 7:** Maximum Ratings

Parameter	Maximum Rating	
LED Junction Temperature (T <sub>j</sub> )	150°C	
Storage Temperature <sup>1</sup>	-40°C to +95°C	
Operating Case Temperature <sup>2</sup> (T <sub>c</sub> )	95°C	
Soldering Temperature <sup>3</sup>	300°C or lower for a maximum of 6 seconds	
	BXRC-xxx10Fo-B-8x	BXRC-xxx10Fo-C-8x
Maximum Drive Current <sup>4</sup>	540 mA at ≤85°C 405 mA at 95°C	720 mA at ≤85°C 540 mA at 95°C
Maximum Peak Pulsed Drive Current <sup>5</sup>	770mA	1030mA
Maximum Reverse Voltage <sup>6</sup>	-60V	-55V

Notes for Table 7:

1. The F90 product is robust enough to pass our internal humidity test but it is still more sensitive compared to regular LED array product. The product needs to be stored in a dry environment. It is not recommended to use the product in a damp environment that directly exposes it to moisture.
2. For IEC 62717 requirement, please consult your Bridgelux sales representative.
3. Refer to Bridgelux Application Note AN31: Assembly Considerations for Bridgelux Vero LED Arrays.
4. Arrays may be driven at higher currents however lumen maintenance may be reduced and warranty will not apply.
5. Bridgelux recommends a maximum duty cycle of 10% and pulse width of 20 ms when operating LED Arrays at maximum peak pulsed current specified. Maximum peak pulsed currents indicate values where LED Arrays can be driven without catastrophic failures.
6. Light emitting diodes are not designed to be driven in reverse voltage and will not produce light under this condition. Maximum rating provided for reference only.

# Performance Curves

**Figure 1: Vero10B Drive Current vs. Voltage**

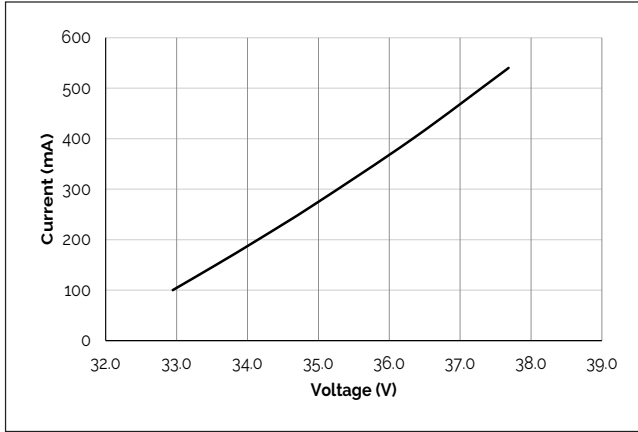

**Figure 2: Vero10C Drive Current vs. Voltage**

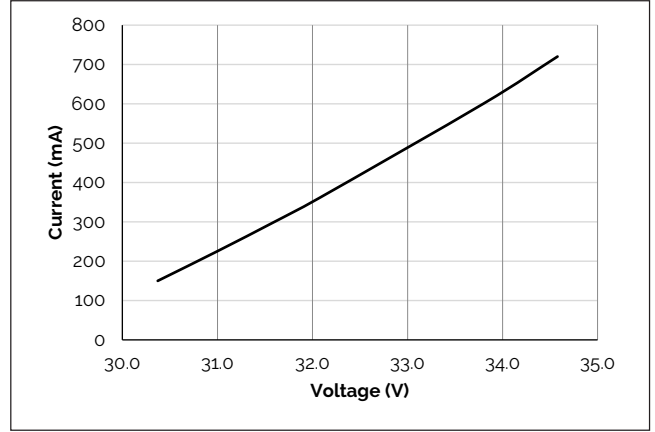

**Figure 3: Vero10B Typical Relative Flux vs. Current**

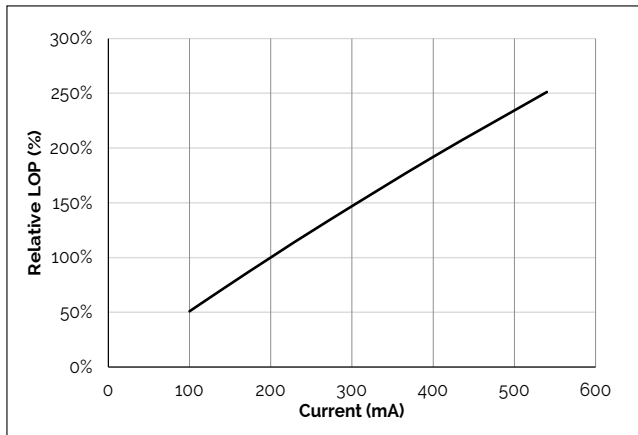

**Figure 4: Vero10C Typical Relative Flux vs. Current**

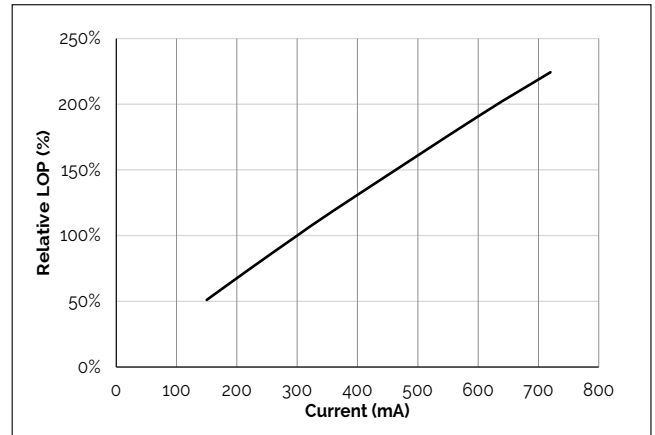

**Figure 5: Typical DC Flux vs. Case Temperature**

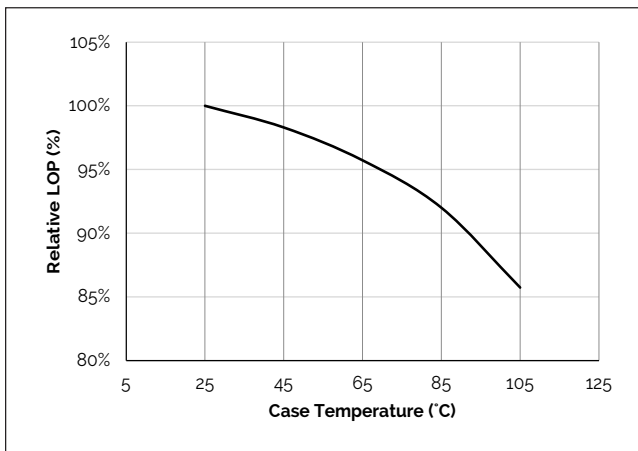

**Figure 6: Typical DC ccx Shift vs. Case Temperature**

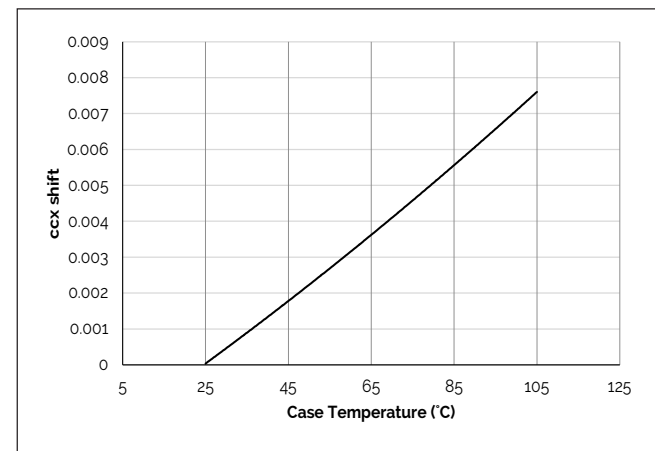

Notes for Figures 1-4:

1. Bridgelux does not recommend driving high power LEDs at low currents. Doing so may produce unpredictable results. Pulse width modulation (PWM) is recommended for dimming effects.
2. Products tested under pulsed condition (10ms pulse width) at nominal test current where  $T_j$  (junction temperature) =  $T_c$  (case temperature) = 25°C.

Note for Figures 5-6:

1. Characteristics shown for Warm White.

# Performance Curves

**Figure 7: Typical DC ccy Shift vs. Case Temperature**

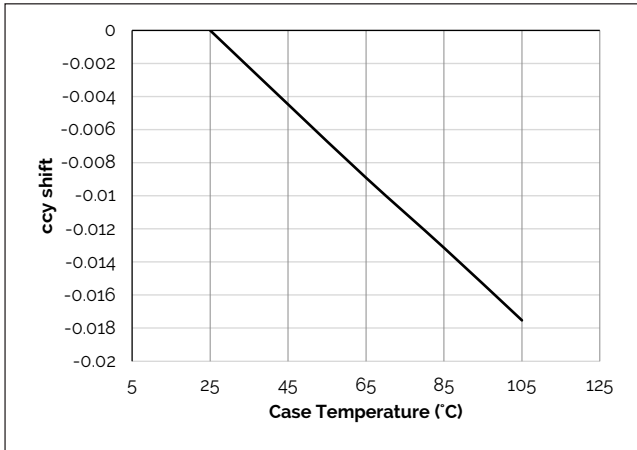

**Figure 8: Vero10B Drive Current vs. ccx Shift**

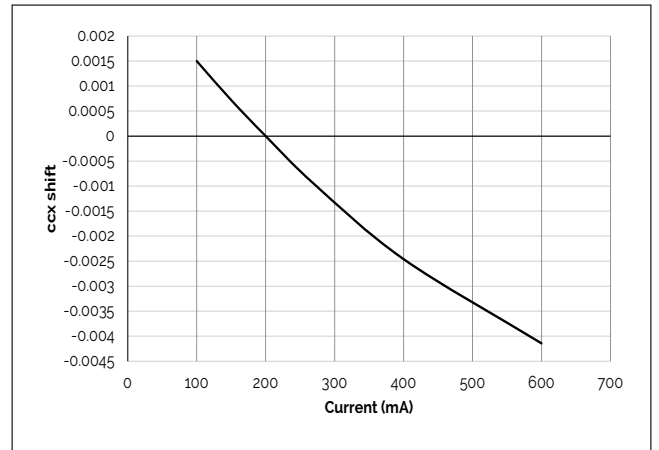

**Figure 9: Vero10B Drive Current vs. ccy Shift**

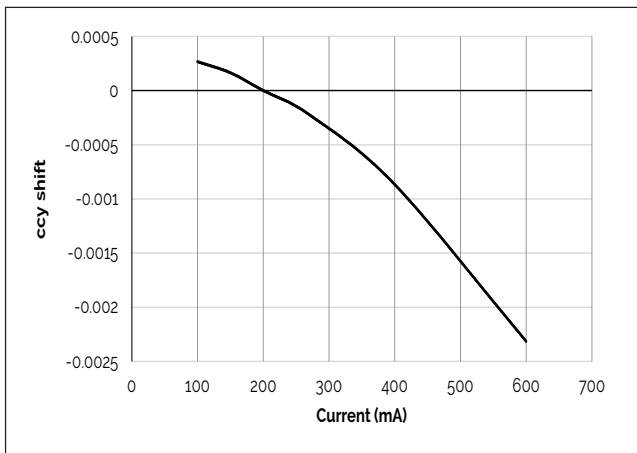

**Figure 10: Vero10C Drive Current vs. ccx Shift**

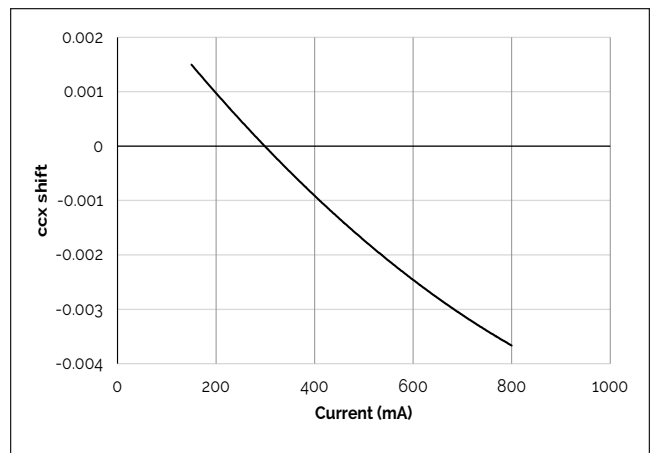

**Figure 11: Vero10C Drive Current vs. ccy Shift**

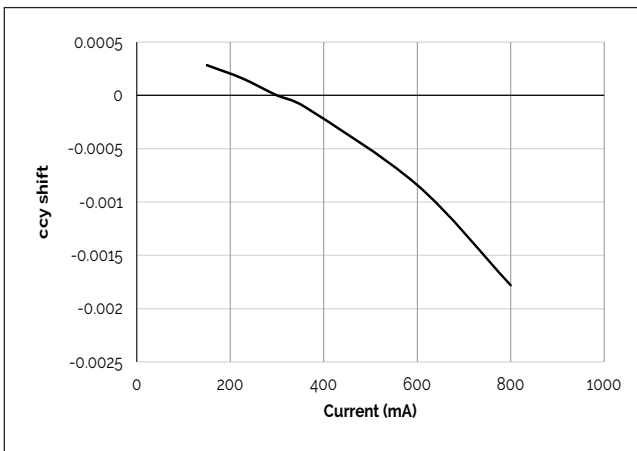

**Figure 12: Derating Curve**

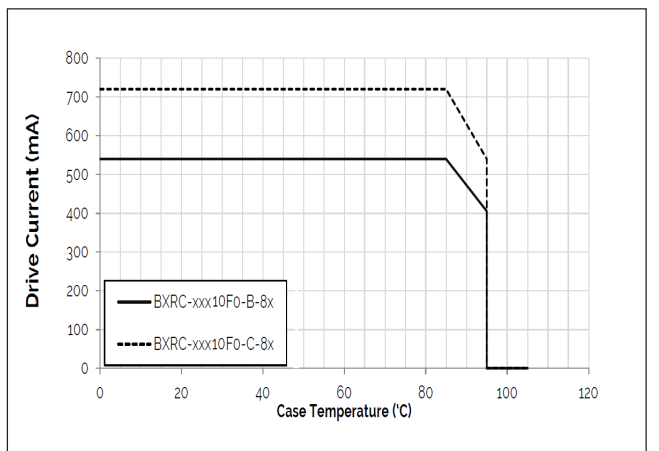

Note for Figures 7-11:

1. Characteristics shown for Warm White.

# Typical Radiation Pattern

**Figure 13: Typical Spatial Radiation Pattern**

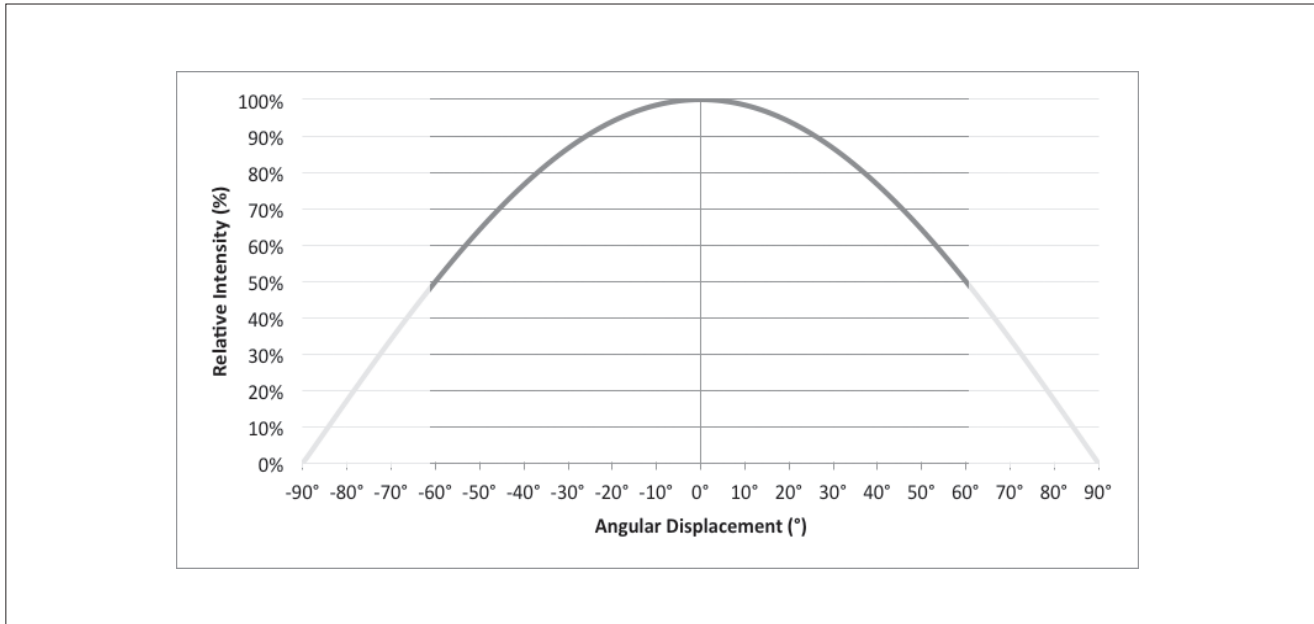

Notes for Figure 13:

1. Typical viewing angle is 120°.
2. The viewing angle is defined as the off axis angle from the centerline where intensity is ½ of the peak value.

**Figure 14: Typical Polar Radiation Pattern**

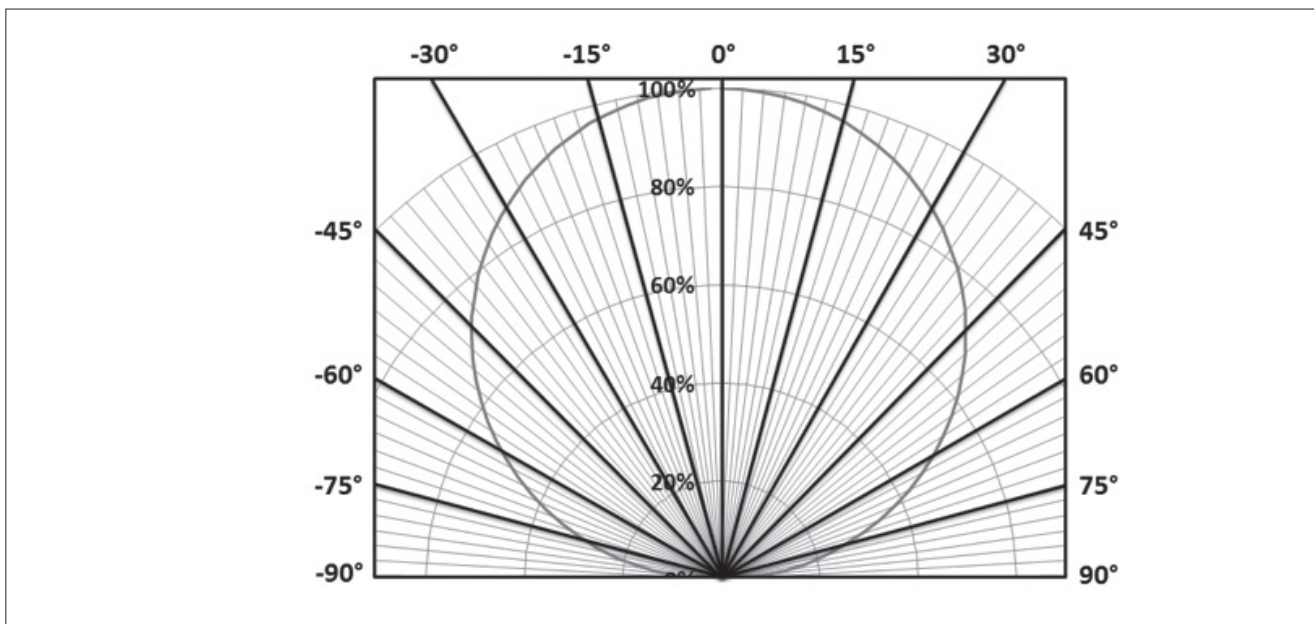

# Typical Color Spectrum

Figure 15: Typical Color Spectrum

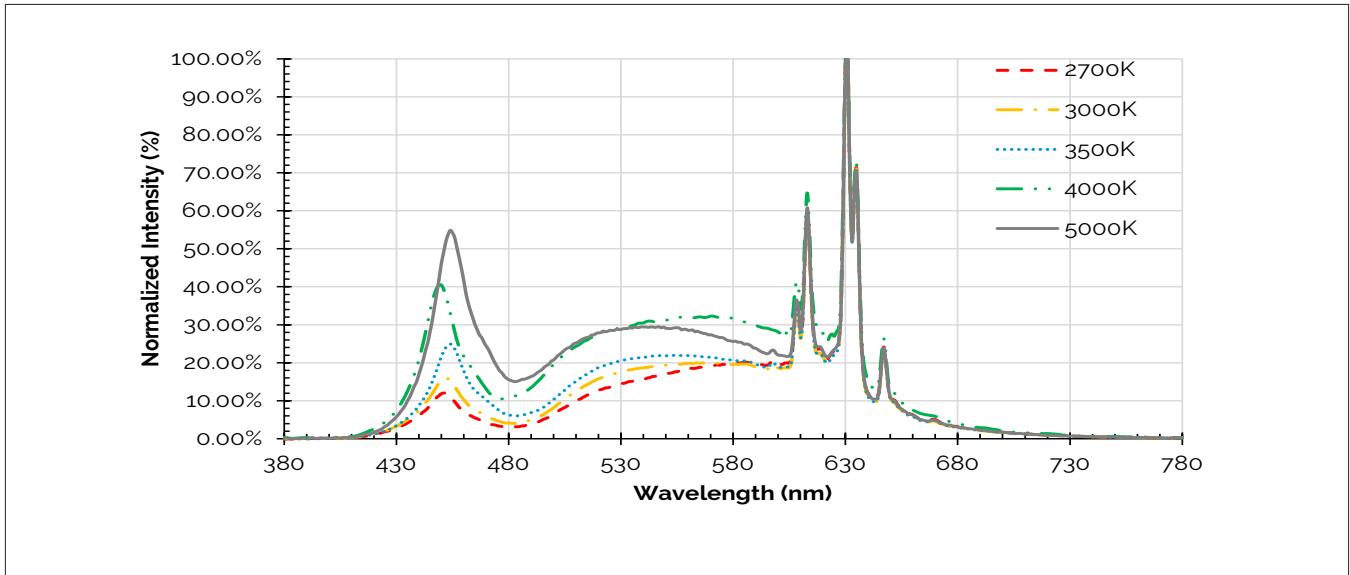

Notes for Figure 15:

1. Color spectra measured at nominal current for  $T_j = T_c = 85^\circ\text{C}$ .
2. Color spectra shown is 2700K and 90CRI.
3. Color spectra shown is 3000K and 90 CRI.
4. Color spectra shown is 3500K and 90 CRI.
5. Color spectra shown is 4000K and 90 CRI.
6. Color spectra shown is 5000K and 90 CRI.

# Color Binning Information

**Figure 16: Warm, Neutral and Cool White Test Bins in xy Color Space**

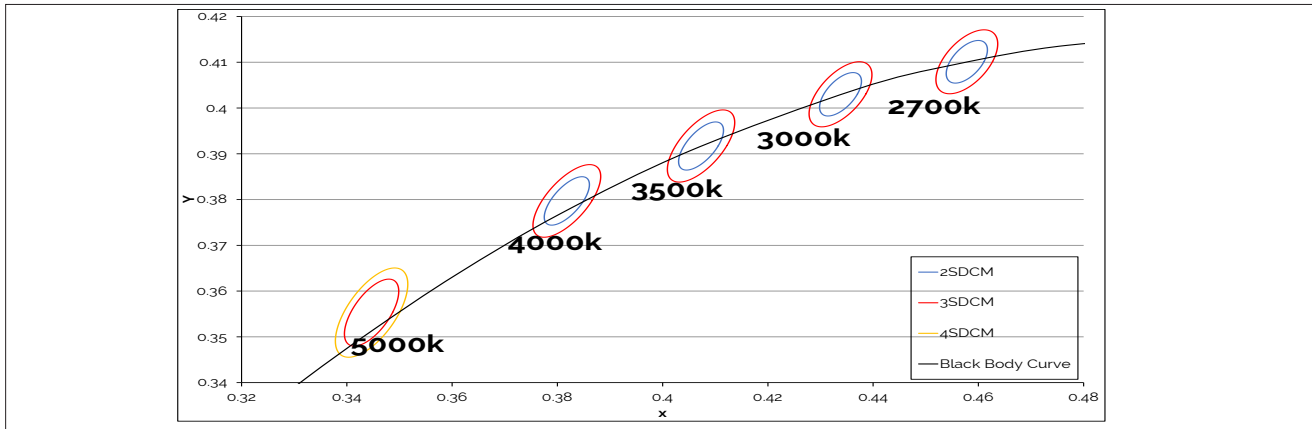

Note: Pulsed Test Conditions,  $T_c = 85^\circ\text{C}$

**Table 8: Warm and Neutral White xy Bin Coordinates and Associated Typical CCT (product is hot targeted to  $T_c = 85^\circ\text{C}$ )**

Bin Code	2700K	3000K	3500K	4000K
ANSI Bin (for reference only)	(2580K - 2870K)	(2870K - 3220K)	(3220K - 3710K)	(3710K - 4260K)
83 (3 SDCM)	(2651K - 2794K)	(2968K - 3136K)	(3369K - 3586K)	(3851K - 4130K)
82 (2 SDCM)	(2674K - 2769K)	(2995K - 3107K)	(3404K - 3548K)	(3895K - 4081K)
Center Point (x,y)	(0.4578, 0.4101)	(0.4338, 0.403)	(0.4073, 0.3917)	(0.3818, 0.3797)

**Table 9: Cool White xy Bin Coordinates and Associated Typical CCT (product is hot targeted to  $T_c = 85^\circ\text{C}$ )**

Bin Code	5000K
ANSI Bin (for reference only)	(4745K - 5311K)
84 (4 SDCM)	(4801K - 5282K)
83 (3 SDCM)	(4835K - 5215K)
Center Point (x,y)	(0.3447, 0.3553)

Note for Tables 8-g:

1. Bridgelux maintains a tolerance of +/- 0.007 on x and y color coordinates in the CIE 1931 color Space.



# Mechanical Dimensions

**Figure 17: Drawing for Vero10 LED Array**

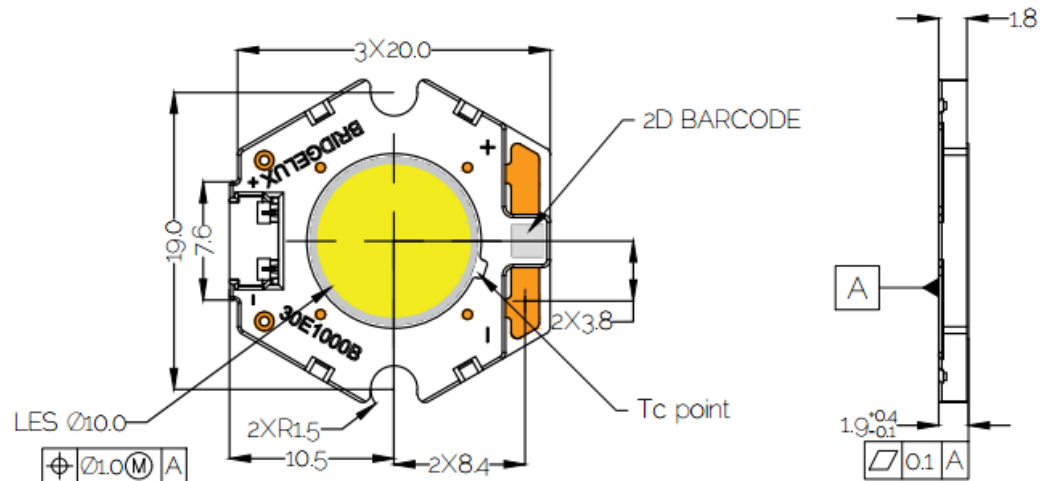

Notes for Figure 17:

1. Drawings are not to scale.
2. Dimensions are in mm.
3. Unless otherwise specified, tolerances are  $\pm 0.10\text{mm}$ .
4. Mounting slots (2X) are for M2.5 screws.
5. Bridgelux recommends two tapped holes for mounting screws with  $19.0 \pm 0.10\text{mm}$  center-to-center spacing.
6. Screws with flat shoulders (pan, dome, button, round, truss, mushroom) provide optimal torque control. Do NOT use flat, countersink, or raised head screws.
7. Solder pads and connector port are labeled "+" and "-" to denote positive and negative, respectively.
8. It is not necessary to provide electrical connections to both the solder pads and the connector port. Either set may be used depending on application specific design requirements.
9. Refer to Application Notes AN30 and AN31 for product handling, mounting and heat sink recommendations.
10. The optical center of the LED Array is nominally defined by the mechanical center of the array to a tolerance of  $\pm 0.2\text{mm}$ .
11. Bridgelux maintains a flatness of 0.10mm across the mounting surface of the array.

# Packaging and Labeling

Figure 18: Drawing for Vero 10 Packaging Tray

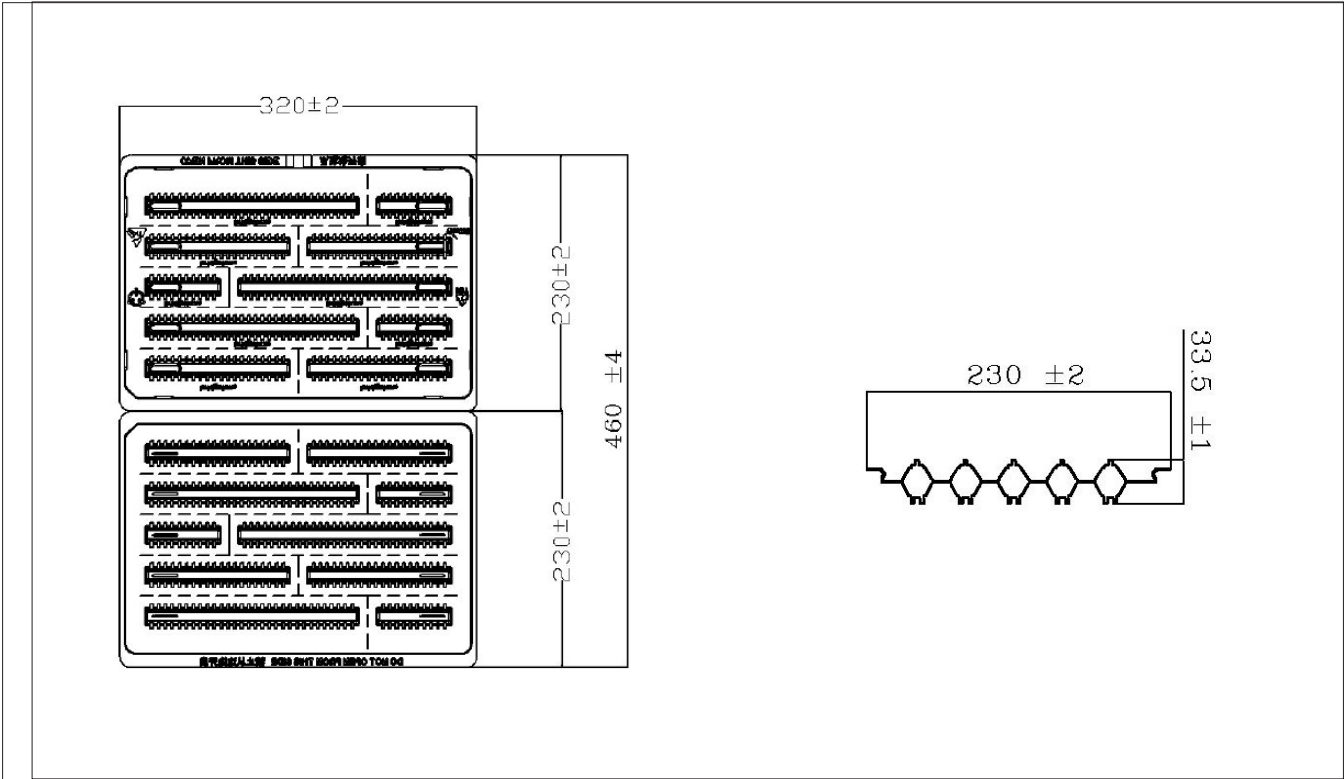

- Notes for Figure 18:
1. Dimensions are in millimeters.
  2. Drawings are not to scale.

# Packaging and Labeling

Figure 19: Vero Series Packaging and Labeling

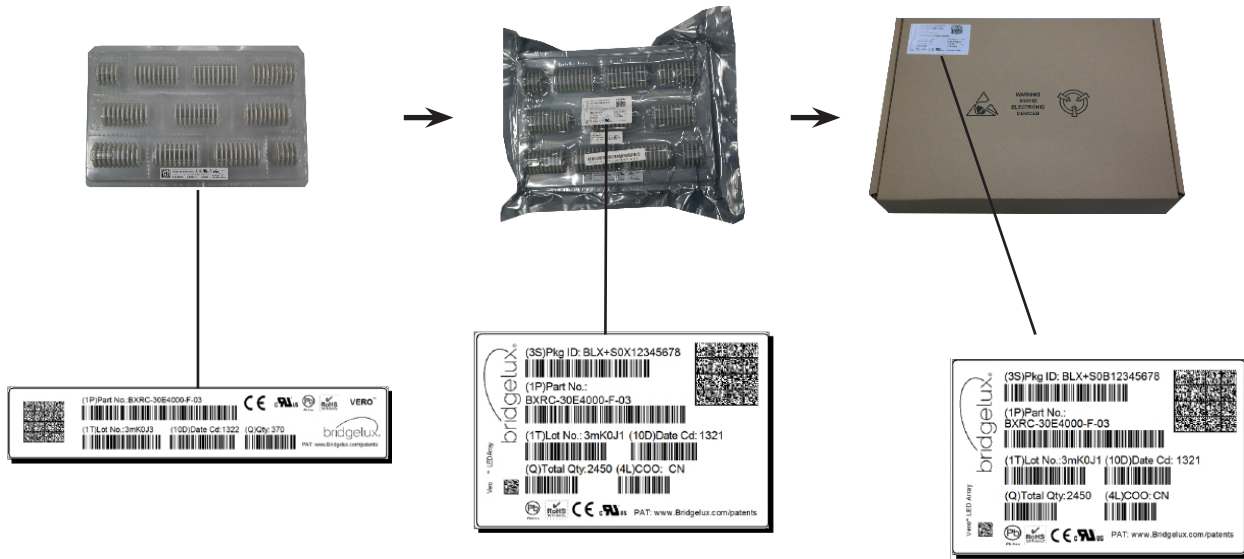

Notes for Figure 19:

1. Each tray holds 200 COBs.
2. Each tray is vacuum sealed in an anti-static bag and placed in its own box.
3. Each tray, bag and box is to be labeled as shown above.

Figure 20: Product Labeling

Bridgelux COB arrays have laser markings on the back side of the substrate to help with product identification. In addition to the product identification markings, Bridgelux COB arrays also contain markings for internal Bridgelux manufacturing use only. The image below shows which markings are for customer use and which ones are for Bridgelux internal use only. The Bridgelux internal manufacturing markings are subject to change without notice, however these will not impact the form, function or performance of the COB array.



# Design Resources

## Application Notes

Bridgelux has developed a comprehensive set of application notes and design resources to assist customers in successfully designing with the Vero product family of LED array products. For all available application notes visit [www.bridgelux.com](http://www.bridgelux.com).

## Optical Source Models

Optical source models and ray set files are available for all Bridgelux products. For a list of available formats, visit [www.bridgelux.com](http://www.bridgelux.com).

## 3D CAD Models

Three dimensional CAD models depicting the product outline of all Bridgelux Vero LED arrays are available in both IGS and STEP formats. Please contact your Bridgelux sales representative for assistance.

## LM80

LM80 testing has been completed and the LM80 report is now available. Please contact your Bridgelux sales representative for LM-80 report.

# Precautions

## CAUTION: CHEMICAL EXPOSURE HAZARD

Exposure to some chemicals commonly used in luminaire manufacturing and assembly can cause damage to the LED array. Please consult Bridgelux Application Note AN120 for additional information.

## CAUTION: RISK OF BURN

Do not touch the Vero LED array during operation. Allow the array to cool for a sufficient period of time before handling. The Vero LED array may reach elevated temperatures such that could burn skin when touched.

## CAUTION

### CONTACT WITH LIGHT EMITTING SURFACE (LES)

Avoid any contact with the LES. Do not touch the LES of the LED array or apply stress to the LES (yellow phosphor resin area). Contact may cause damage to the LED array.

Optics and reflectors must not be mounted in contact with the LES (yellow phosphor resin area). Optical devices may be mounted on the top surface of the plastic housing of the Vero LED array. Use the mechanical features of the LED array housing, edges and/or mounting holes to locate and secure optical devices as needed.

# Disclaimers

## MINOR PRODUCT CHANGE POLICY

The rigorous qualification testing on products offered by Bridgelux provides performance assurance. Slight cosmetic changes that do not affect form, fit, or function may occur as Bridgelux continues product optimization.

## STANDARD TEST CONDITIONS

Unless otherwise stated, array testing is performed at the nominal drive current.

# About Bridgelux: Bridging Light and Life™

At Bridgelux, we help companies, industries and people experience the power and possibility of light. Since 2002, we've designed LED solutions that are high performing, energy efficient, cost effective and easy to integrate. Our focus is on light's impact on human behavior, delivering products that create better environments, experiences and returns—both experiential and financial. And our patented technology drives new platforms for commercial and industrial luminaires.

**For more information about the company, please visit**

**[bridgelux.com](http://bridgelux.com)**

**[twitter.com/Bridgelux](https://twitter.com/Bridgelux)**

**[facebook.com/Bridgelux](https://facebook.com/Bridgelux)**

**[linkedin.com/company/bridgelux-inc-\\_2](https://linkedin.com/company/bridgelux-inc-_2)**

**[youtube.com/user/Bridgelux](https://youtube.com/user/Bridgelux)**

**WeChat ID: BridgeluxInChina**



46410 Fremont Boulevard

Fremont, CA 94538 USA

Tel (925) 583-8400

**[www.bridgelux.com](http://www.bridgelux.com)**